

A STUDY OF KINSHIP AND MARRIAGE
AMONG THE MUDUGAS OF ATTAPPADY IN KERALA

A Thesis submitted to the University of Hyderabad
for the award of the degree of
Doctor of Philosophy
in
Anthropology

by
GEORGE THARAKAN. C



Department of Anthropology
School of Social Sciences
University of Hyderabad
Hyderabad 500 046
December 1998

Roll No 91SAPH02

in memory of my Grand Parents

Appachan, Ammachi, Appai, Ammachi

**Department of Anthropology
School of Social Sciences
University of Hyderabad
Hyderabad -500 046**

This is to certify that I, George Tharakan C, have carried out the research embodied in the present thesis entitled " *A study of kinship and marriage among the Mudugas of Attappady in Kerala* " for the full period prescribed under Ph D ordinances of the University of Hyderabad

I declare to the best of my knowledge that no part of this thesis was earlier submitted for award of any research degree in any other University

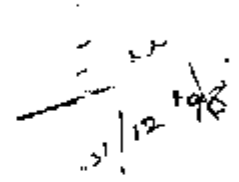
George Tharakan C

Date 31-12-98

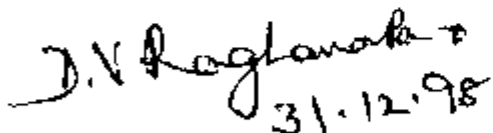
31.12.98
Prof D V Raghava Rao
(Research Supervisor)
SUPERVISOR
Department of Anthropology

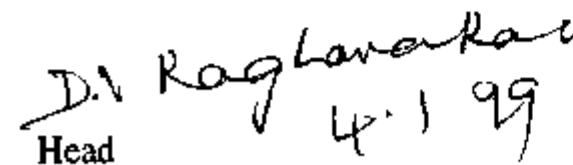
4.1.99
Head
Department of Anthropology
School of Social Sciences
University of Hyderabad-500 046
HEAD
Department of Anthropology
University of Hyderabad
HYDERABAD-500 046

7/1/99
Dean
School of Social Sciences
University of Hyderabad
Hyderabad-500 046
DEAN
School of Social Sciences

ACKNOWLEDGEMENTS

This thesis is based on my intensive field work among the Mudugas of Attappady in Kerala from March 1995 to June 1995 and later from March 1996 to December 1996 with a further short visit in March 1997. During my field work and after that in writing this thesis, I have received help, guidance and co-operation from my teachers, friends, and informants.

First and foremost I express my profound gratitude to my research supervisor Professor D V Raghava Rao who has trained me in kinship theories and Muduga ethnography through his scholarly guidance. I am most grateful to him for his valuable comments and for many helpful discussions. I owe a great deal to his kindness and hospitality shown to me during my research.

At the Department of Anthropology, during my M Phil and Ph D programme, I have benefited from many discussions and suggestions from my teachers. I am specially grateful to Dr K K Misra, Dr P Venkata Rao, Dr Siva Prasad and Dr B V Sharma for their valuable suggestions and sincere help at various stages of my research. I express my gratitude to late Professor M Kodanda Rao for his advice during the initial stage of my work.

I specially thank Professor T R Sharma (former Dean) Department of History, and Professor V V N Somayajulu, Dean, School of Social Sciences, for their help and co-operation during my research.

I express my gratitude to Professor C G Hussam Khan, Department of Anthropology, Karnatak University, to whom I owe a personal and an intellectual debt.

I take this opportunity to thank all my friends for their love and invaluable help during my research which has placed me under a great debt and everlasting obligation to them.

I am grateful to my parents, brothers, sister and relatives for their love and concern towards me and the constant inspiration all through my research without which it would have been difficult for me to complete this endeavor.

I offer my thanks to the officials of the Attappady Tribal Development project, Tribal Culture Research and Training Institute, Hyderabad, and the Indira Gandhi

Memorial Library, University of Hyderabad ; for their help and co-operation towards me in furnishing necessary records and information regarding my research,

I would like specially to thank Professor (Emeritus) N Ravi, Tropical Botanical Garden, Palode, Thiruvananthapuram, in identifying most of the plants and providing me with their scientific details

The debt which cannot ever be settled is with the people of Thaze-Abbannoor with whom I stayed, and all the many Mudugas and Kurumbas of neighbouring hamlets who gave me the privilege of sharing their life during my field work. It would be invidious to mention their names for my friends and helpers were many. To all of them I express my deepest thanks and gratitude.

With pain, I do express here, my deep and heartfelt gratitude to my friends, Kakkı, Chonkeacchan, Ragiacchi and Ramaswami who left Attappadi and Thaze-Abbannoor for ever, not waiting for my next visit.

CONTENTS

	Page No.	
<i>Acknowledgements</i>		
<i>Illustrations</i>		
<i>Abbreviations</i>		
<i>Maps</i>		
Chapter 1	Introduction	1-11
Chapter 2	The Mudugas - Society and Culture	12-28
Chapter 3	Descent ideology and organization of local descent group	29 – 72
Chapter 4	Family organization and domestic activities	73-139
Chapter 5	Kinship terminology and behaviour pattern	140-199
Chapter 6	Marital exchange and alliance relationship	200 – 261
Chapter 7	Rites of passage and prestations	262-298
Chapter 8	Conclusion	299-304
<i>Glossary</i>		305-315
<i>Bibliography</i>		316-324
<i>Photographs</i>		

Illustrations

Page No

Tables

2 1	Distribution of Mudugas	16
2 2	Age-Sex distribution of Mudugas	17
2 3	Educational status of the Mudugas	18
4 1	Widowed/separated persons attached to household of kin	76
4 2	Members attached to households of other than parents, spouse or children	78
4 3	Types of Families / households	94
4 4	Numerical composition of domestic groups	95
4 5	Attachment of old couples to household of km	102
4 6	Sexual division of labour	106
4 7	Distribution of abled members per household	110
4 8	Unit of economic co-operation and other activities	113
4 9	Composition of hunting groups indicating the nature of relationship	115
4 10	Distribution of adjacent farm lands of close km	121
4 11	Type of kin relationship existing between <i>beethakarar</i> at Thaze-Abbannoor	126
4 12	Number of <i>beethakarar</i> and the type of relation with respect to the head of the household at Thaze-Abbannoor	127
5 1	Muduga kinship terminology	141
5 2	Muduga kinship terms in reciprocal sets	159
5 3	Term of address for a male speaker	166
5 4	Term of address for a female speaker	167
6 1	Type of marriages	202
6 2	Bride-price paid and received by the male members of Thaze-Abbannoor	240
6 3	Distribution of marital exchanges between hamlet	253

Figures

2 1	Vertical section of Muduga hut	19
2 2	Ground plan of a Muduga hut	20
2 3	Finger linings on the wall of Muduga hut	20
2 4	Finger linings on the floor of Muduga hut	21
2 5	Diagrammatic representation of hamlet and its surround territory	23

3.1	Genealogy showing relationship between Ramanan and Kadcti	31
3.2	Genealogy showing relationship between shanmukam and agnates of Chitoor hamlet	32
3 3	Genealogy showing the inheritance of (A) <i>Moopan</i> and (B) <i>Mannukaran</i> at Thaze-Abbannoor	41
3 4	Pattern of inheritance of name	43
3 5	Inheritance of name in Velli's family	43
3 6	Genealogical composition of Thaze-Abbannoor hamlet	
3 7	Bride-price payment of Mathan	59
3 8	Co-residence of agnates and non-agnates and the shift of natal land during burial and dry-funeral	60
3 9	Temporary right on the mother's body and the children attained by anakkal ooru on payment of bnde-pnce	62
3 10	Performance of <i>nigaal nokkal</i>	63
3 11	Cycle representing the regeneration of land and people	68
4 1	Genealogical composition of Chathan's family	75
4 2	Structure of relationship in nuclear family	79
4 3	Composition of Kakkilinkan's family	80
4 4	Genealogical composition of Rangan's family	81
4 5	Genealogical composition of Mallan's family	82
4 6	Genealogical composition of Linkan's family	83
4 7	Genealogical composition of Panali's family	84
4 8	Genealogical composition of Krishnan's family	85
4 9	Genealogical composition of Kali's family	86
4 10	Genealogical composition of Kullan's family	87
4 11	Genealogical composition of Gopi's family	87
4 12	Genealogical composition of Rangan's family	88
4 13	Genealogical composition of Chekidan's family	89
4 14	Genealogical composition of Chelli's family	90
4 15	Genealogical composition of Chathi's family	91
4 16	Genealogical composition of Man's family	92
4 17	Genealogical composition of Chekidan moopan's family	93
4 18	Genealogical composition of Chonke's family	93
4 19	Joint household of Chelli, Chellan and Sivalinkan	97
4 20	Different levels of corporate units of Kaden's family	114
4 20(a)	Pattern of <i>beethe</i> exchange at Thaze-Abbannoor hamlet	123
4 21	<i>Beethe</i> shares from Karimi's household	125
4 22	Different spheres of economic unit of Ramanan's household	129
4 23	Different spheres of food sharing unit of Panali	130
4 24	Genealogical representation of different stages in the development cycle of Patti's domestic group	134
4 25	Transitional stages of Patti's family	135

5 1	Structure of Mudugakinship terminology	142
5 2	Muduga kinship terminological structure depicting the rule of bilateral cross-cousin marriage	143
5 3	Marriageability between members of first ascending generation	144
5 4	Marriageability between members of ego's generation	146
5 5	Marriageability between members of first descending generation	151
5 6	Marriageability between members of second ascending generation	153
5 7	Marriageability between members of second descending generation	154
5 8	Distinction of cross and parallel relatives	156
5 9	Genealogy showing Kaden's relationship with Chekidan	162
5 10	Genealogy showing Nanjappan's relationship with Kaden's wife	163
5 11	Structure of Muduga kinship categories	171
5 12	Vegetative propagation as an analogy for parent-child attachment	178
5 13	Analogy of <i>konthan-konhi</i> relationship	195
5 14	Generational equivalence of kinship behaviour	190
5 15	Genealogical representation of Bokken's marriage and the subsequent relations	194
5 16	Genealogical representation of Gundi's relationship with Nanji	196
6 1	Genealogy showing relationship between Eriyan and Neeli	205
6 2	Genealogy showing relationship between Panali and Kuppe	206
6 3	Genealogy showing relationship between Bokken and Vanji	207
6 4	Genealogy showing relationship between Kakkı and Barme	207
6 5	Genealogy showing relationship between chelli and Ponnai	208
6 6	Alliance relationship showing relationship between the patrilineal segments of Thaze- Abbannoor and Boodar	210
6 7	Alliance relationship between the patrilineal segments of Thaze-Abbannoor and Veetiyoor	211
6 8	Alliance relationship between the patrilineal segments of Thaze-Abbannoor and Karuvara	213
6 9	Alliance relationship between patrilineal segments of Karuvara, Thaze-Abbannoor and Veetiyoor hamlet	215
6 10	Tying of broom analogous to marital exchange	217
6 11	Analogy of <i>saval</i> plant and family relations	221
6 12	Stages of bride-price payment	239
6 13	Paying and receiving of bride-price by a male ego	241
6 14	Bride-price payment during Lacchi's funeral	250
7 1	Exchanges associated with child-birth	265
7 2	Exchanges associated with tonsure ceremony	266
7 3	Exchanges associated with puberty ceremony	269
7 4	Exchanges associated with marriage	270
7 5	Offering of <i>savu-seela</i> during Ramaswami's death	273

7.6 <i>Uimei atturathu</i> and <i>thanni atturathu</i> during Kalamoopan's funeral	277
7.7 <i>Uimei atturathu</i> and <i>thannatturatk</i> during Ramaswami's funeral	278
7.8 Exchange relation during funeral ceremony	283
7.9 The soul-cycle	284
7.10 Exchange relation between agnates and affines during dry-funeral	292

Maps

- 1 1 Kerala - showing **Palakkad** district and Attappady area
- 1 2 Village map of Attappady showing the distribution of Muduga hamlets

Photographs

- A Muduga Nuclear Family
- A Muduga Couple
- A Muduga Woman
- Pariya-Panam* payment during marriage
- Woman sowing seeds - shifting cultivation
- Affines sharing labour
- Child rearing - fondling the child

Abbreviations for kin types :

Kin types	Abb.
father	F
mother	
brother	B
sister	Z
son	S
daughter	D
husband	H
wife	W
parent	P
child	C
sibling	Sb
spouse	Sp
same sex	SS
opposite sex	OS
male speaker	m sp
female speaker	f sp

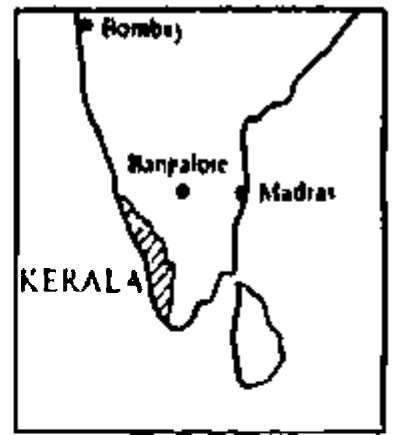
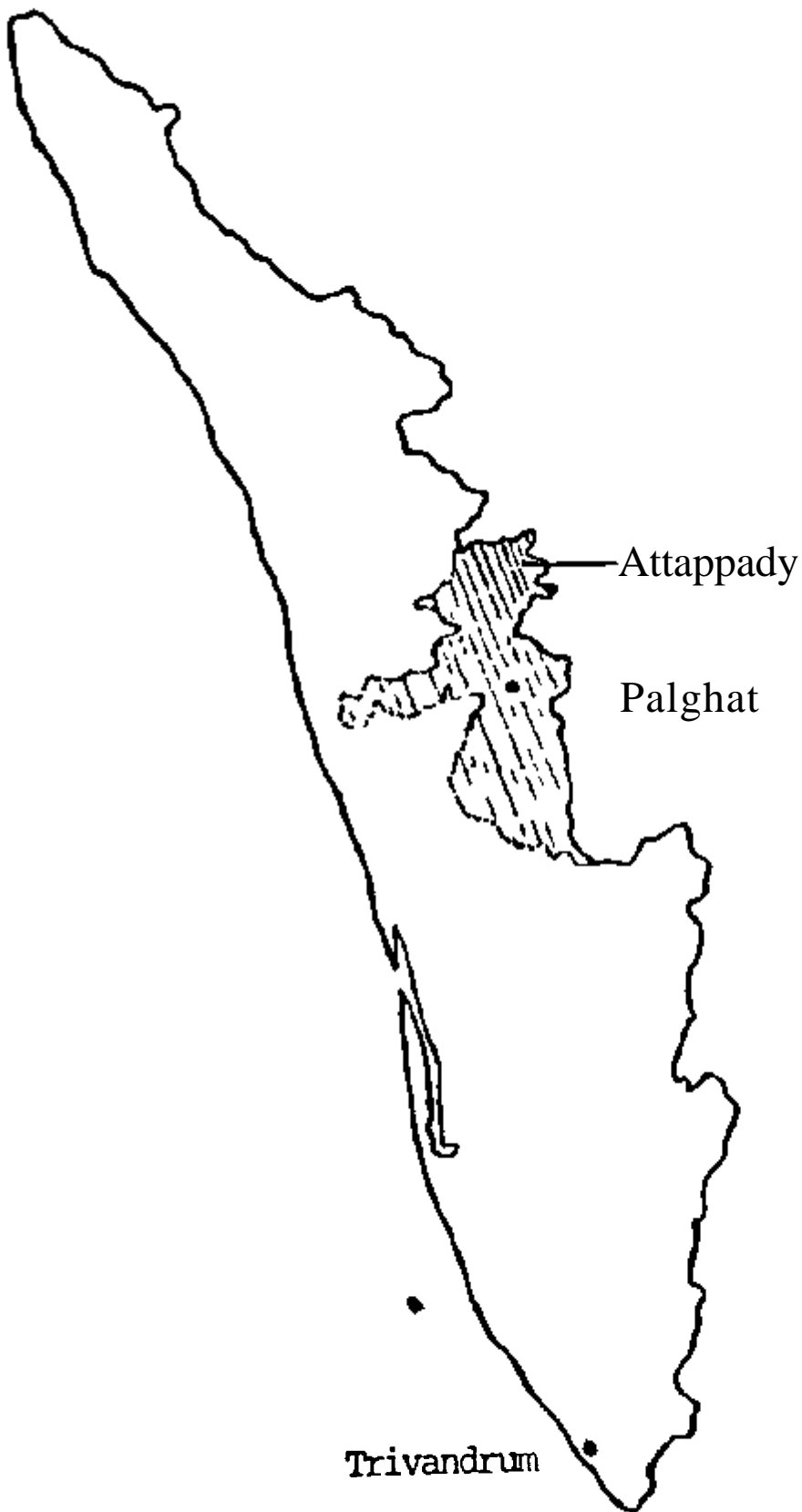

Kerala - Showing Palghat district and area of study: **Attappady**

1

INTRODUCTION

Kinship as an important organizing principle in human society play crucial role in the regulation of behaviour and thus enjoy a privileged position in Social anthropology. Most anthropologists consider kinship as an "area of anthropological discourse where the ground rules are clearly laid down" (Good and Barnard 1984: 2) and is central to the theoretical development of the discipline. This subfield attempts to apprehend comprehensively the nature and rule of descent, marriage alliance, relations of affinity, kinship terminology and behaviour, and the like which occupied a prime of place in the general discussion of kinship theory during the fifties, sixties and seventies of this century.

There are two major structural approaches adopted in the study of kinship, they are descent and alliance. Descent theory which dominated the British Social anthropology from the 1940s to 1960s was developed out of earlier anthropological theories which had as their central concern the relationship between kinship and territory and between family and kin group. This school of thought interpreted the kinship behaviour in terms of the function of corporate groups, sibling solidarity and agnatic unity, and drew attention to important issues such as the organization of local groups, kinship relations, regulations of marriage, residence, inheritance and succession.

The definition of descent as employed by structural analyst goes back to the work of Rivers for whom the term descent referred to "membership of a group" (1924: 85). For Radcliffe-Brown (1924), "patrilineal descent" and "territory" were the two basic elements binding members together in the organisation of corporate unilineal descent group. Based on Radcliffe-Brown's idea, later anthropologists too viewed that membership to corporate groups are based on descent. This assumption led the Cambridge anthropologists (Fortes and Goody) to state categorically that the use of the term 'descent group'¹ had sense only in connection to unilineal descent groups.

The notion of descent as the main structural principle of kinship established from African ethnographies came under increasing attack during the 1960s on a number of fronts. When ethnographic data became extensively available from other parts of the world, especially from societies encouraging cross-cousin marriages with prescriptive or preferential marriage rule, "Africanist descent model" failed to explain aptly the working of these systems. The strongest challenge to descent theory was the development of alliance theory by Lévi-Strauss (1949) and his followers like Leach (1951, 61), Dumont (1953) and Needham (1962), which depicted the structure as an entailment of perpetual alliance between groups and not as a logical entailment of unilineal descent. Alliance theory proved to be aptly applicable to societies where positive or prescriptive marriage rules are present.

The debate between descent theory and alliance theory was mainly on two levels - ethnographic and theoretical. In the former case, it was the debate between ethnographers working predominantly in Africa on the one hand and in south-east Asia on the other. On theoretical level it was a discussion between Radcliffe-Brown's (1940) structural-functionalism and Lévi-Strauss's (1949) structuralism. However, both theories were based on principles which are confined within one scientific paradigm, the central issue being, as reviewed by Holy, "the problem of how the social reality is structured or how the components of the structure are integrated into a system" (1976: 109). The major criticism raised against both these structural principles — the descent approach or model also labeled as the "jural model" (Verdon 1980) and the alliance model has been their inability to treat as problematic the relations between structural forms and actual behaviour. Thus descent theory has to face serious challenge from both alliance theorists as well as critics of structuralist theory.

Firth (1957, 63), Goodenough (1955, 70), Davenport (1959), and Schneider (1965) opposed the restricted use of descent to unilineal descent group. Schneider (1965) criticised structural model for its failure to distinguish clearly descent as an abstract or conceptual entity from descent group, the concrete counterpart. Fredrick Barth (1966, 73) departs from structural analysis pointing out the necessity for an analysis through which structural premises and individual behaviour are connected.

Ethnographic data from **New Guinea** came as a further blow by which many anthropologists **felt** that the Africanist jural model could not account for a greater part of the **non-African** ethnography. **This** opened a new debate on the relationship between descent and local group based on the explicit variation between New Guinea societies and African societies which led to the **characterisation** of the former as "loosely structured" as Held (1957) and Pouwcr (1960) expressed. The structuralists' failure to explain **this** variation was mainly due to their exclusive focus on structure and their major objective to analyse how **this** structure works rather than dealing **with** actual behaviour. For Langness (1964) the problem in the interpretation of New Guinea data is the problem of the discrepancy between the ideology of descent and actual behaviour which as Holy says is due to "the continuing use of concepts developed within the framework of structural theory for answering the questions asked outside **this** framework" (1976: 118). Later anthropologists (Langness 1964, Strathern 1969, 73, Scheffler 1966, 73, Barnes 1962, De Lepervanche 1967-68) argued for the formulation of the structure in such a way that it would subsume not only the normative actions but all the variations in the actual behaviour as well. Elkin (1938), Meggit (1962), Berndt (1964, 76), and Hiatt (1962, 66) have implicitly introduced a different representation of social organization by defining groups, not in terms of "binding elements" but with reference to specific activities. By shifting the focus onto activities, these anthropologists have succeeded in dissociating descent group from local descent group. Regarding this variation between descent group and local group, Goodenough (1962: 5) notes that "it is common for local groups to be organized as descent group" rather than descent groups being localised.

It came to be accepted among anthropologists (Sahahn 1965, Langness 1964, De Lepervanche 1967-68, Scheffler 1966 etc.) that descent is an ideology in whose term the solidarity of the local group is expressed, however, does not depict actual behaviour, as aptly pointed out by Sahahn when he says, "a descent doctrine does not express group composition but imposes itself upon the composition" (1965: 104). This was an emphasis on the need to distinguish clearly between local descent group and descent, the former being **defined** on the basis of actual behaviour and interaction and the latter on the basis of formal criteria of membership (Scheffler 1966, Keesmg 1971). Thus territory and

agnatic idioms are seen as mutually reinforcing each other, and not necessarily being prior over the other as an analytical principle. Based on this thesis, Scheffler (1966, 73) distinguished three analytical levels of social phenomena - descent construct (conceptual or ideational representation), descent-phrased rules (rules upon which they are organised), and descent group (behaviour which are governed by descent-phrased rules). Similar approach has been put forward by Needham (1972) adopting a three-level model of social reality namely, prescription (categorical level), preference (jural level), and practice (behavioural level) for heuristic purposes. This theoretical approach rests essentially on the understanding of how the interaction of the three levels of categories, rules, and practices define social relations and groups. Here, an explicit recognition of the ideology and behaviour, category and group, and structure and practices forms the basis of analysis, not treating them as exclusive of each other but as interrelated.

Before getting on to explicate these ideas, it is important however to examine the theoretical approaches to Dravidian kinship, the subfield to which Muduga kinship system falls.

Studies on Dravidian kinship

The most significant single contribution to our understanding of Dravidian kinship is the one given by Louis Dumont (1953, 57, 64, 67, 83). Viewing Dravidian kinship as an expression of marriage, Dumont demonstrates affinity as an "enduring system" through which the continuity of alliance from one generation to the next occurs. His thesis that the terminology is based on alliance rather than descent, still dominates discussions of the system. Though a dominant contribution, Dumont's theory amounts to major drawbacks which stems from his very notion that the analysis of kinship terminology is an end in itself and that terminology has nothing to do with actual behaviour. Nur Yalman (1962, 67) views Dravidian terminology in the setting of Sinhalese bilateral kinship, and his attempt to understand South Indian kinship in the same perspective was an early criticism to Dumont's theory of alliance groups. Rejecting the rule of descent exogamy as the primary factor, Yalman tries to discover the principles inherent in the structure of kinship with the help of terminological categories and rules of behaviour emphasising the strong element of bilaterality. Later, Burkhart (1978) in his study of Udayars, an upper caste in

Tamil Nadu, supports Dumont's view. He notes that the circles of alliance among the Udayars are like those of Sinhalese "micro-caste" (Yalman 1967) which follow the marriage practices of bilateral cross-cousins and elder sister's daughter as in Tamil Brahmins and Adi-Dravida castes. He also rejects the existence of "wrong marriage" as in the case of Kandyam Sinhalese (ibid). Mc Cormacks (1958) analyses the implication of sister's daughter marriage in the wider frame work of Dravidian kinship system stating that the custom is always found in association with cross-cousin marriage.

Adopting a three-level model of social reality proposed for heuristic purposes by Needham (1972), Anthony Good (1981) examines the marriage system of Kondaiyan Kottai Maravar of South India in the frame work of prescription, preference and practice, and thereby emphasising the interrelation of categories, rules and behaviour in the understanding of social relations. Good finds fault with the use of the terms "kin" and "affines" proposed by Dumont as problematic and replace it with the concepts of "cross" and "Parallel" as they are neutral analytical concepts (1980, 81, 91).

Adapting the approach of "cultural unity of India", Carter (1974) brings out the similarities between North and South India though there is a diversity with regard to the rules of descent and kin classification. By comparing the kinship terminology of North and South India Carter points out that the cross-cousin marriage which is embedded and expressed in kinship terminology is only a surface structure and concludes that Dravidian terminology do not imply cross-cousin marriage. But Carter's analysis of Dravidian terminology fails to eliminate the presumption of cross-cousin marriage, because his "two-class equivalence rule" (1973: 37) as Trautmann says, "is in fact essentially identical to [our] 'opposite-sex cross cousin – spouse equation rule'" (1981: 61), which implies bilateral cross-cousin marriage.

However, Trautmann (1981) offered a comprehensive account of the Dravidian kinship system by stating that the many local kinship systems called Dravidian are historically related to one another as descendants of a common ancestral system, emphasising the rule of bilateral cross-cousin marriage as ancestral to all Dravidian systems. Khan's (1994) study of 'Marriage and Kinship among the Muslims in South India' tries to analyse the structure and functioning of Muslim kinship and marriage pattern in the Dravidian milieu thereby emphasising the importance of a

synthetic model of both **'descent'** and **'alliance'** theory in the understanding of **Dravidian** kinship system

Emphasising the role of descent and sibling solidarity in the Dravidian kinship terminology, Reddy (1984) brings out the logical inconsistency met with Dumont's terminological distinction which classifies **'mother'** along with 'father' as parallel kin and **'father's sister'** along with 'mother's brother' as **cross-kin**. He argues for a new scheme of cross/parallel distinction classifying **'mother'** along with 'mother's brother' and 'father's sister' along with **'father'**. More recently, Rudner (1990, 97) also finds fault with Dumont's terminological distinction which ignores the use of secondary terms in Dravidian system in distinguishing actual affines from cross-kin or potential affines. Rudner points out that the group of actual affines **is** not the same as the group of potential affines and claims that the **"Dumont conflates marriage and marriageability"** (1990 167). Defending Rudner's (1990 153) critique of Dumont's association of affinity with marriage ability, Parkin (1996 291) makes clear that for Dumont affinity need not necessarily imply the relation between spouses, since affines are seen persons of the same sex. Parkin criticises Rudner in wrongly claiming that Dumont has treated actual Tamil terms inaccurately for maintaining the consistency of his model and strongly argues that whatever deviation actual terminologies exhibit from Dumont's model, they need not challenge that model since "they are not sufficient to suggest an alternative model that is radically different in structure" (1996 296).

Challenges to Dumont's structural explanation have come most notably from the cultural and ethno-sociological approach (Barnett 1976, David 1973, Fruzzetti and Oster 1976, Fruzzetti, Oster and Barnett 1982, Kapadia 1993, 95, Cecilia Busby 1997) attempting "to relate structural features of the kinship system to cultural ideas which underlie the categorical distinctions made in the terminology" (Busby 1997 29). David (1973), in his study of Tamils in the Jaffna, modifies Dumont's formula "kinship equals consanguinity plus affinity" (Dumont 1961 81) as **"consanguines equals concorporals plus affines"** (David 1973 528). He reports that, for the Jaffna Tamils, a woman's substance changes completely on marriage to that of her husband, so that she and her brother, and consequently their children are no longer substantially related at all. David points out that the people's own notion of classification of kinsmen basing on the natural

substance and a comparison of these symbols provide scope for **the understanding** of similarities and differences in the definition of cultural constructs cross-culturally. .

As David tries to **find** out a paradigmatic scheme for South India which can be extended to North India, **Fruzzetti**, Oster and Barnett (1982) attempt to see the similarities **in** the cultural construction of people **in** Bengal and Tamil Nadu According to them **in** Tamil systems, other than lineal or vertical relationship, kindred or horizontal relationship **is** emphasised and forms the defining principle

Focussing on the kinship discourse **of** various non-Brahmin and Brahmin castes **in** Tamilnadu, **Kapadia** (1994), taking a different step **in** the frame work of women's views on kinship argues that from the female perspective, Tamil kinship **is** as much a negative as a positive value She complains that **Dravidian** kinship **is** portrayed **in** the dominant male ideology, and points out that these discourses ideologically misrepresent kinship, depicting it as entirely positive Deviating from a core **ethno-sociological** approach , **Busby** (1997), influenced by **Bourdieu** (1977) and **Trawick** (1990), attempts for an intuitive 'practice-based' "understanding of relationships and kinship categories **in** the **Dravidian** kinship system" which **is** **universal** " and has to do with the understanding of gender" (1997 33) For her, terminological categories do not rest on marriage, as **Dumont** argues, but on prior considerations of **marriageability** which ultimately rests on consideration of relatedness

The ethno-sociological approach though extremely important in the understanding of the nature of the kinship system and marriage practices, exhibits a number of problems in the analysis carried out and has been variously criticised (eg **Dumont** 1983, **Good** 1991 , **McGilvray** 1982) The major draw back of **this** approach, as **Busby** says, is that "the theories put forward are too precise and localized, and it has proved impossible to generalize from them" (1976 31), and cannot explain a wide spread phenomena such as **Dravidian** kinship It **is** not only that these theories are context specific, but fails to understand the distortions, contradictions and variations that invariably occur within the same group

Bilateral tendencies :

A balance between patrilineal and affinal kin in Dravidian kinship has been long back emphasised by Dumont in his argument against the importance of descent line propounded by Radcliffe-Brown, Fortes and other descent theorists. However, this centrality of the affinal kin is not carried as far as it is reported by Yalman (1962, 67) who illustrates the importance of bilateral paradigm for the understanding of Dravidian kinship denying the existence of descent group. Dumont's (1957) analysis assumes that the Dravidian system have a strong descent system and these strongly distinguished patrilineages are united through 'alliance'. But according to Kapadia, the Tamil groups indicated a much more bilateral tendency "with a strong stress on the unity of km (kindred) rather than on their separateness and consequent need for alliance" (1994: 283).

It is observed that some of the Dravidian groups are patrilineal with bilateral cross-cousin marriage rule exhibiting tendencies of bilateral society. This predominance of matrilineal kin suggest these patrilineal systems as having a 'balanced bilaterality' as termed by Kapadia for the Tamil non-Brahmins (1994: 288). What it does mean is that the dogma of patrilineal descent operates as only one principle among several, rather than as the sole principle. Thus, as Radcliffe-Brown insists, it is the understanding of the degree of emphasis on the patrilineal principle and how it is used" that matters (1950: 14).

Revising Homan's and Schneider's (1955) explanation of unilateral cross-cousin marriage, Allan D Coult (1962) put forward his assumption that the determinant of unilateral as well as bilateral cross-cousin marriage is the jural authority to dispose of a woman in marriage. According to him bilateral cross-cousin marriage occurs in societies in which jural authority over female is either vested in the woman herself or is split between her patriline and matriline kin (bilateral authority). Thus, on the basis of above hypothesis Coult predicts that bilateral cross-cousin marriages are associated with bilateral societies or with weaker unilineal descent groups.

However, it is significant to point out here that when bilateral cross-cousin marriages occur in a patrilineal system it cannot be concluded as having a weaker unilineal system, rather it throws light to the need for an understanding of the discrepancy

between the ideology of descent and the actual behaviour, and the bilateral tendencies exhibited by the system

It is precisely in this direction that an approach is attempted emphasising the structural understanding of Muduga kinship system at the same time depicting the actual behaviour from ground and the variations from the ideal occurring within the system. Here, social phenomena is not restricted just to the level of ideal norms and rules, but there is need also to look for and understand as Jones says, "how items and events are seen by cultural natives and in peoples rules and recipes for how to act in various situations" (1998: 60). In this view, the Muduga kinship can be analysed from an approach explaining the underlying logic of relationship and understanding the native meaning of kinship categories which make sense of the ground reality, meaningfully uniting the structure and practice of the system. A structural understanding of group grounded in the opposition between sharing and exchange forms the basis for the analysis of social phenomena.

Taking lead from this approach, the present study attempts to portray the ethnography of the Mudugas of Attappady through the framework of kinship and marriage which are rooted in the hard facts of descent and alliance. The study aims to analyse the behaviour pattern and system of terminology by which they identify members as belonging to particular categories with definite roles and responsibilities which makes for marriage exchange, inheritance of property and the performance of rights and obligations during life-cycle rituals. Thus the objective is also to understand the nature of interaction and inter-relationship between the kin categories - agnates and the affines which forms the underlying principle of Muduga social structure. This theoretical framework takes into consideration the ideology and behaviour of the Mudugas establishing a connecting link between the two realms. Since ideology or rule is the representation of practices, the objective is to understand the practices and to know how the people represent their own practices.

It is significant to note that among the few studies done on Mudugas (reviewed in chapter 2), there is hardly any reckonable full length intensive study of Muduga social organisation, and more over these works were earned out not with kinship and marriage as the main interest. There is absolutely no empirical information on family, kinship and

marriage among the Mudugas. Thus there is an urgent need to understand the various aspects of Muduga kinship system and marriage practices. It is precisely in this direction that the study is aimed to bring out the actual working of the institutions of kinship and marriage of the Mudugas of Attappady in Kerala, in an ethnographic approach

Methodology

This study is based on an independent field investigation employing mainly techniques of participant observation and interviews. To know many important aspects of the social organisation of Mudugas, these techniques were found to be more suitable. At the same time, some of the basic data like population, number of households, age and marital status, education, etc., of the Mudugas were collected by census schedules. Genealogical method was used for collecting data on descent and alliance. Out of the 21 Muduga hamlets in the Attappady area, Veetiyoor, Anakkal, Thaze-Kakkupadi, Mele-Kakkupadi, Pottikkal, Thaze-Abbannoor, Mele-Abbannoor, and Ommala were selected and household survey was conducted for 191 households. Along with this, data regarding marriage and alliance relationship were also collected from two Kurumba hamlets namely, Thadikundu and Thaze-Thodukkı. Field work was carried out among the Mudugas of Attappady initially for about four months from March 1995 to June 1995. For a more detailed study, Thaze-Abbannoor hamlet was selected and data has been collected through participant observation, interviews and case studies by staying along with them from March 1996 to December 1996 with a further visit in March 1997.

Chapterisation

The ethnographic data on Muduga kinship and marriage and the accompanying analyses have been presented in the following format in eight chapters.

The first chapter introduces the theoretical context and frame work in which the work is earned out. After giving a review of the literature on kinship studies in general and Dravidian kinship in particular, the significance and objectives of the study will be discussed.

Chapter two titled "The Mudugas - Society and culture" gives a brief account of the socio-cultural background of the Mudugas of Attappady. This chapter will also

discuss various **other aspects like** population, sex-ratio, distribution of Muduga hamlets and oilier factors **like** ecology, economy and the people of the area.

Chapter three titled "**Descent** ideology and organization of local descent **group**" discusses the meaning and ideology of descent as conceived by **the** people. **The** chapter also gives a description of the nature of descent group, **its** constitution and range of corporatness as well as the degree of emphasis of descent principle **in** various spheres of social hfe and day to day activities

Fourth chapter deals **with** the family / household and domestic organization of **the Mudugas**. The composition and development cycle of family, division of labour, inheritance of property etc , **will** be discussed **in** detail. The nature and composition of different levels of corporate domestic units and the sharing of labour and food **within this** units also forms an important part of **this** chapter

In the fifth chapter, titled "Kinship terminology and behavioural pattern", the **kin** terminological paradigm and its empirical operation **with** reference to individual relationships and km groups **will** be discussed. Analysing the km classification and kinship behaviour, attempts **will** be made to assess the implications of positive marriage rules for the structure of Muduga kinship terminology

Chapter **six** **is** concerned **with** marriage and alliance relationship and focus attention on the rules and regulations of both the traditional and present system of marriage among the Mudugas. **This** section then goes on to take a detailed look on marriage negotiations, procedure of marriage, ceremonies connected **with** marriage, transactions of gifts and services accompanying marriages. The incident of cross-cousin marriage and the implication of the bilateral cross-cousin marriage **with** respect to the Muduga kinship system **will** be discussed

Chapter seven, titled "Rites of passage and prestations", presents a detailed description of various life cycle rituals and the ceremonies and rituals connected **with** it. The right and obligations of agnate and affinal relatives on these occasions as well as the making of gifts and prestations **will** also be described **in this** chapter

The final chapter gives a summary of all the preceding chapters and draws conclusion from the analysis of ethnographic findings presented **in** these chapters

THE MUDUGAS - SOCIETY AND CULTURE

The Mudugas are a small tribe with a population of around 3000 people inhabiting mainly the Attappady area of Palakkad district (erstwhile Palghat) in north Kerala, bordering the Coimbatore district of Tamilnadu. They are also seen spread in a few hamlets like Adivaram, Kalkothi, Kozhikoodam, Savakadu and Thanikandi in the border areas of Tamilnadu State.

The Mudugas were mentioned for the first time as a tribes known as "Mudukkan" in an order issued by the Madras Government in November 1938 and the census report of 1941 recorded a population of 1,193 "Mudugans" from the Malabar district. There is some obvious confusion or error in transliteration with regard to these terms "Mudukkan" or "Mudugan". Later both these names were replaced by the name "Muthuwar" in official records. The official list of scheduled tribes (1956) recorded them to be the same as the Muthuwars of Devikulam taluk of Kottayam district. Though, some ethnographers, (Louiz 1962), support this with a view that a section of the "Muthuwans" (Muthuvans) of Kottayam may have moved through the mountain tracts to the forest of Attappady valley, the fact remains that the Mudugas and the Muthuvans exhibits no similarities and they represent entirely different groups.

It is also noted that the name "Mudugas" have been referred in-correctly as "Mudukkan", "Mudugan", "Muthuwan" and "Mudugar" by both the ethnographers and the census enumerators. However, to avoid further confusion it is preferred here to use the name "Mudugas" for this tribe as followed by A Ariyappan (1958), Furier-Heimendorf (1959), and P R G Mathur (1977).

There is some controversy regarding the origin of the name of Mudugas. Ethnographers who referred to them as "Muthuvan" explained that the name must have originated from their "primitive" custom of carrying children on their "muthuk" meaning back (Louiz 1962, Fuchs 1973). But this explanation appears not so convincing, since such a custom never existed among the Mudugas of Attappady as far the observation

goes. If at all this custom existed among any **tribe**, it must have **been** among the "Muthuwans" of Kottayam district as Thurston (1909) described. Moreover, the attribute of the custom of carrying children on the back suits more appropriate to the Muthuvans than Mudugas since the former has lexical **similarities** with the Malayalam word "muthuvu", (back) and hence their name as Muthuvan.

Informants say that, the name "Mudugas" is derived from the word *idi muduguthu*, meaning "Peals of thunder". They believe that they were born along with thunder and hence originally were known as Idi Muduga (*idi-thunder*). They also have a notion that they are as strong as thunder. This aspect regarding the etymology of the term is clearly emphasized in their famous saying "*munthipirannavan aaru ? mun konte kettiy avan aaru ? idi mudugan aan !*" meaning "who is the one that has borne first ? who is the one that knot their hair to the front ? it is idi Muduga !"

Dieter B Kapp (1978, 80, 85) identifies Mudugas along with the Kurumbas of Nilgiri and Wayanad and suggests that "Kurumba is a collective term for the tribal complex subdivided into seven groups -Betta Kurumbas, Jenu Kurumbas, Mulla Kurumbas, Urali Kurumbas, Alu Kurumbas, Palu Kurumbas, and the Mudugas. However, he says that "all these tribes are distinct ethnic groups differing in language, culture, religious beliefs, and customs and manners" (1978 168)

Mudugas inhabit mostly the forest areas of south-western foot hills and in the southern part of the Attappady valley distributed in about 21 hamlets. The Muduga hamlets called *ooru* is a cluster of huts (*koorai*) varying between 10 to 30 huts.

Attappady literally meaning valley (*padi*) of leeches (*atta*) is an area in the Mannarkad taluk of Palakkad district situated between 10° 54' and 11° 14' north latitude and 76° 27' and 76° 48' east longitude. It is about 250 square miles in extent, and lies behind the ridges of western ghats which extend south-west to the Palghat gap (Aiyappan 1948). Attappady is one of the prominent forest regions of Kerala with abundant vegetation, and extensive forest growths providing a refreshing greenness to the prospect, and most part of the area has an elevation ranging from 1200 to 3000 feet. The area comprises of three panchayats namely, Agali, Pudur and Sholayur with a tribal population of about 9551, 7130 and 7591 respectively (according to 1991 census).

The main tribes living in the Attappady region are **Irulas**, Mudugas and **Kurumbas** numbering about 19,299, 2755 and 1280 respectively (ATDP survey 1991)¹. Apart from the tribal communities, Attappady valley **is** also inhabited by many caste groups of Hindus, Christians and Muslims **from** the plains and the Tamil speaking Goundans and **Chettis**. An analysis of the population of Attappady shows that the tribal people who once formed the **majority is** getting reduced to a minority year by year. The tribal population of the area according to 1971 census was 15,809 as against 13,133 **in** 1961 census. However, **this is** due to the increased immigration of Christians and Hindus from the plains of Kerala and Tamil Goundans from Coimbatore. The tribals which formed the majority **in** 1961 census (63% of the total population) was reduced to a minority (40.3%), and still further **in** 1981, they are reduced to 33.18% **eventhough** the population increased to 20,659. In 1991, tribal people number 24,272 forming just 26.95% of the total Attappady population.

The area **is** tropical **in** climate and vegetation **with** occasional stands of Cycas palms and certain thorny shrubs like *Lendana camera (parale chedi)*. The annual rainfall varies from 40 mm from Coimbatore side to 200 mm in the dense evergreen forests in the western and southern parts of the valley, bulk of which received during the two monsoons — the south-west monsoon, which brings most of the rain, between June and August and the north-east monsoon in October and November. The Mudugas identify mainly three seasons — a dry season called *kara gah* between March and May, a wet or rainy season called *koda gah* between June and August and the cold winter season during September to November called as *konda gah*. November to February is the major harvest season and **is** termed according to the harvest of respective crops like *same gah* (Nov – Dec) and *tuvarigah* (Jan – Feb) etc.

Bhavanu and *Siruvani* are the two important rivers which drain the whole of Attappady valley and these rivers have all the potentialities for irrigating the entire area. However, no development schemes have been put forward as yet for the effective utilization of this water resource, and most of the area still remains dry.

The red loam mixed laterite soil **is** generally fertile. In the Summer, soil **is** too hard for digging and **in** the monsoon **it is** too muddy and sticky. The **principal** crops cultivated by the tribal people of the area are *rai* (finger millet - *Eleusine corocana*),

same (little millet – *Panicum miliaceum*) ; *tuvati* (red gram – *Cajanus indicus*) ; *cholam* (maize - *Zea maize*) ; *kaduku* (mustard-*Brassica nigra*); *keera* (amaranth - *Amaranthus hypochondriacs*) ; *sakkare* (cucumber – *Cucumis sativus*) etc., on the sloppy dry lands. On the small amount of low lying wet land between hill tracks and in the swamps, paddy and plantains are grown

The Mudugas, one of the three tribal groups of Attappady are seen mainly in the Agali and Pudur panchayat and rarely in Sholayur panchayat. They claim as the early inhabitants of the area and subsist mainly on shifting cultivation supplemented by occasional hunting and gathering. With regard to the former history of the tribal groups of Attappady, wayanad, Nilgiri etc., various theories have been evolved. Kapp concludes that these tribal communities

“ may well be considered as the modern representatives of ancient warrior tribes who once inhabited the plains of South India. After encountering calamitous defeats, the survivors fled and dispersed seeking shelter in the jungly areas of the Nilgiri Hills. While settling there, they were forced to completely change their former mode of living and adapt themselves to their new surroundings and so, in the course of time, experienced a gradual re-development into tribes of food gatherers, hunters and — later on — shifting cultivators” (1985: 518)

Even if the Mudugas have migrated into this land from other parts, there is no evidence that in doing so they displaced any previous inhabitants. This area remained greatly under-populated before 1950, after which the immigration from the plains started.

The Mudugas were mentioned for the first time as a tribes known as “Mudukkan” in an order issued by the Madras Government in November 1938 and the census report of 1941 recorded a population of 1,193 “Mudugans” from the Malabar district. There is some obvious confusion or error in transliteration with regard to these terms “Mudukkan” or “Mudugan”. Later both these names were replaced by the name “Muthuwar” in official records. The official list of scheduled tribes (1956) recorded them to be the same as the Muthuwars of Devikulam taluk of Kottayam district. Though, some ethnographers, (Louiz 1962), support this with a view that a section of the “Muthuwans” (Muthuvans) of Kottayam may have moved through the mountain tracts to the forest of

Attappady valley, the fact remains that the Mudugas and the Muthuvans exhibits no similarities and they represent entirely different groups.

Table 1.1 shows the distribution of Muduga households and Muduga population in the nine hamlets where household survey has been conducted

Table 1 1 Distribution of Mudugas

Name of hamlets	No of households	Males	Females	Total	%	No of people per household
Anakkal	21	60	60	120	12.52	5.71
Veettyoor	24	56	53	109	11.37	4.54
Pottikal	31	70	72	142	14.82	4.58
Thaze-Kakkupadi	18	54	37	91	9.49	5.05
Mele-Kakkupadi	10	26	33	59	6.15	5.9
Cholakkadu	12	24	31	55	5.74	4.58
Ommala	18	30	40	70	7.30	3.88
Mele-Abbannoor	17	38	33	71	7.41	4.17
Thaze-Abbannoor	40	121	120	241	25.15	6.02
Total	191	479	479	958	100	5.01

The table shows the distribution of Mudugas of 191 households in 9 hamlets. From the table it is clear that the number of males and the number of females are almost equal. Out of the total of 958 Mudugas, 479 are males and 479 are females. However, the ratio varies considerably at two hamlets. At Thaze-Kakkupadi hamlet, the number of females per 100 males is 68.51, and at Ommala hamlet, the ratio is 133.3 females per 100

males From the table it is also clear that among the Mudugas, an household consist of an average of 5 01 members. This rate is high at Thaze-Abbannoor, where one household consist of an average of 6 members and it is very low at Ommala hamlet where it is 3 88.

Every Muduga hamlet is a social aggregate consisting of a core of patnhneal kin together with few affines Thus in addition to the male members of the patnhneal descent group along with their wives and children, a Muduga hamlet population also includes some affinal relatives However, all these people refer to themselves as residents of a particular hamlet The hamlet and its surrounding territory represents home for the descent group whose ancestors traditionally settled there and the affines are outsiders who have no permanent ownership or right in it It is seen that in almost all hamlets the percentage of children and babies are more when compared to that of adults Table 1 2 shows the age-sex distribution of 958 Mudugas in the sample

Table-1 2 Age-sex distribution of Mudugas

Age-Group	Male	%	Female	%	Total	%
0 -4	53	11 06	47	9 81	100	10 43
5 -9	71	14 82	70	14 61	141	14 71
10- 14	71	14 82	65	13 56	136	14 19
15- 19	44	9 18	54	11 27	98	10 22
20-24	39	8 14	49	10 22	88	9 18
25 - 29	43	8 97	53	11 06	96	10 02
30-34	40	8 35	36	7 51	76	7 93
35-39	46	9 60	32	6 68	78	8 14
40-44	14	2 92	13	2 71	27	2 81
45-49	19	3 96	17	3 54	36	3 75
50 - 54	13	2 71	12	2 50	25	2 60
55-59	11	2 29	16	3 34	27	2 81
60-64	6	1 25	6	1 25	12	1 25
65 - 69	4	0 83	5	1 04	9	0 93
70-	5	1 04	4	0 83	9	0 93
Total	479	100 00	479		958	100 00

The Table shows that out of the total 958 people, 14 71% falls within the age group 5-9 and 39 35% of the total sample are below the age of 14 52 08% of the people

fall between the age group **15-49** The people above 50 is very rare - 8.55%. It is also seen that among both males and females, the greatest population is between the age group 5-9.

The Muduga dialect which is often referred to by the Mudugas as *mudugar athu nayam* or *muduga basha* is basically of the South **Dravidian** family and contains elements of Tamil, Malayalam and Kannada (Zvelebıl 1981) Tamil however is most predominant in this language and many of the personal names and kinship terms are derived from Tamil The dialect is distinct and is hardly intelligible to Malayalam speakers Nowadays most young men speak in addition some Malayalam and Tamil and they use frequently these languages in their interaction with outsiders Now the literacy and educational status of this tribe is coming up and children seek admission in the Tribal residential school and other government schools Table 1.3 presents the data regarding the educational status of Mudugas at present

Table- 1.3 Educational status of the Mudugas

CLASSES	Males				Females				Grand total	
	Below 15 yrs	Above 15 yrs	Total	Drop outs	Below 15 yrs	Above 15 yrs	Total	Drop outs	Males & Females	%
LP (1-4)	66	41	107	58	42	26	68	34	175	20.39
UP (5-7)	39	30	69	45	36	17	53	38	122	14.21
HS(8-10)	9	30	39	34	8	20	28	22	67	7.8
College	-	5	5	2	-	1	1	1	6	0.69
									Total	370 43.12

The Table shows that 370 (43.12%) out of the total sample is literate at present The literacy rate among the male (51.64%) is higher than among the female (34.72%)

Out of the total sample only 7.8% is high school educated. The Table shows that out of the literate, 63.24% are drop outs

In a hamlet, the huts are seldom in isolation but are mostly built contiguous to each other. Huts of close kin are erected in rows close to one another. Every hut has a rectangular earthen base and a front porch called *dheetti*. There are two tall bamboo posts six feet high in the centre for the roof support. A long pole rests on the posts as the roof centre beam (*bitta*). The sloping roof structures are built up of bamboo splits as rafters (*alagu*) tied with vine overlying the cross poles (*poottu*). *Dharbha* grass (*Poa cynosuroides*) are arranged on top to make a rainproof roof.

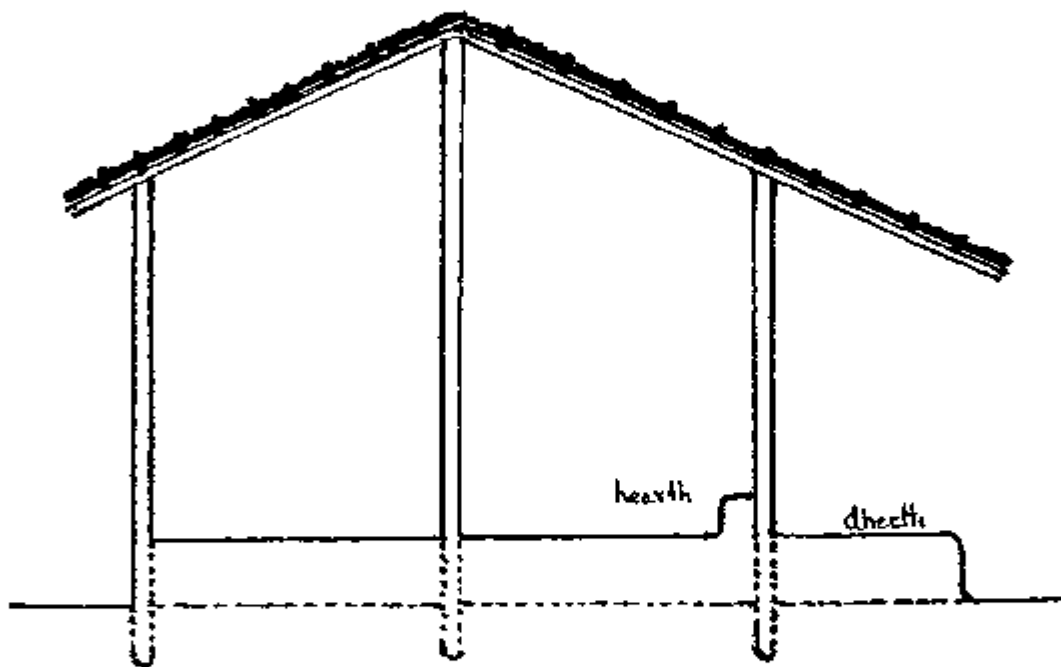

Fig 2.1 Vertical section of Muduga hut

The walls (*goda*) are made of bamboo splits interwoven like basket work and plastered on the inside with clay. There is a small door (*basa*) formed by woven split bamboo's which opens to the *dheetti*. The *dheetti* will be open or closed with bamboo walls. While plastering, linings are made on the floor and the walls by running the fingers, giving rise to varieties or designs. The interior of the hut is divided into two

roughly equal parts, one more secular, behind the **front** entrance called *vettara* and the other, near to fire place, more sacred called as *ullara*.

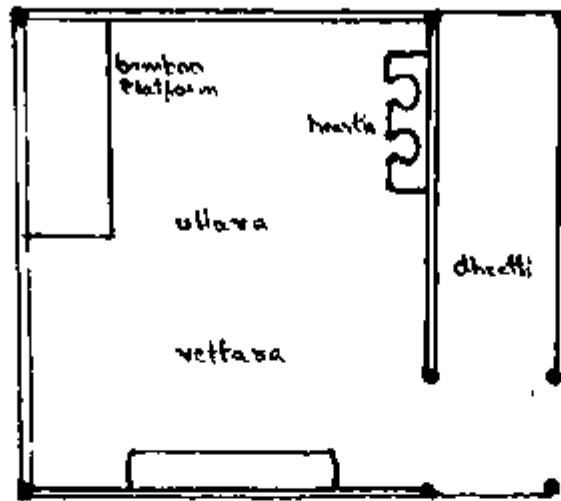

Fig 2 2 Ground plan of Muduga hut

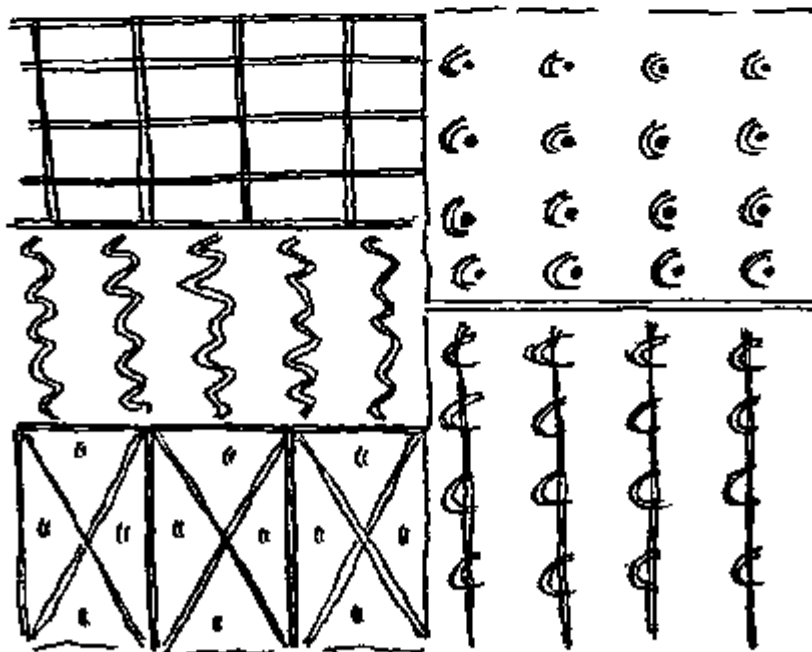

Fig 2 3 Finger lining on the wall of Muduga hut

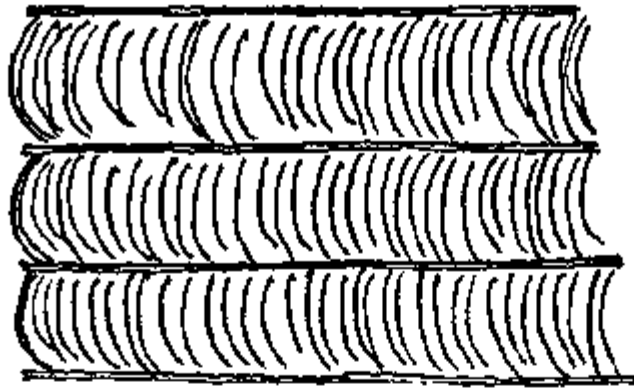

Fig 2 4 Finger linings on the floor of Muduga huts

The dress pattern of the Mudugas is very simple. Women tie a cloth (*seela*) above the breast and knot it below the left arm pit which covers the body upto the knee. Men usually wear lungi and shirt. Women wear ornaments made of silver such as *kammal* (ear-ring), and other aluminium ornaments like *vala* (bangles), *panavala* (broad bangles), *kaikallu* (beaded bangles), *jerry* (decorated copper bangles) and necklaces made of black beads (*keeramala*) and silver coins (*kashu mala*). Nowadays every women wear a small nose ring called *michi* made of gold. Most of the women do tattooing on their forehead.

The Muduga subsistence economy mainly depends on shifting cultivation supplemented by occasional hunting, gathering and fishing. Land is abundant and one can cultivate any extent of land according to his capacity. The cultivation by clearing fresh field and burning is called *kari-kadu krishi* and the usage of previous plot is called *pakka-kadu krishi*². Hoes (*kothu* or *kunthali*) with small narrow blade are the most frequently used implement in soil preparation, and is done mainly by women. Predominant crops cultivated by them are *rai*, *same*, and *tuvan*. Also grown in small quantities are amaranth, beans, maize (corns), cucumber, plantains etc. Food made of *rai* and *same* forms the bulk of their daily diet added with green leaves, tubers and

sometimes meat. Now rice has become an important part of their diet due to the coming of shops and markets.

The **Mudugas** occasionally resort to hunting and fishing to provide them **with** the animal protein they want. Animals most frequently hunted for meat (**kari**), are those which are plentiful or relatively easy to **find** and to shoot or trap and whose meat **is** generally desirable. These animals include mainly *ma* (wild deer - *Rusa unicolor*), *koora ma* (mouse deer - *Tragulus meminna*), *kela* (barking deer - *Muntiacus muntjak*), *Pullima* (spotted deer - *Axis axis*), *belilu* (flying squirrel - *Petaurista philippensis*), *kattu-panti* (wild-pig - *Sus scrofa cristatus*), *eyyan* (porcupine - *Hystrix leucura*), *keen* (mongoose - *Herpestes edwardsi*), *alinku* (pangolin, scaly antater - *Mans crassicaudata*), *utumbu* (monitor lizard - *Varanus bengalensis*) *mijalu* (rabbit - *Lepus nigricollis*), *pokken* (wild cat) *kattu koli* (wild fowls) and few varieties of birds.

Traditionally, the hunting of animals was by trapping and they did not use bow and arrows. Now-a-days they hunt in the forest **with** ordinary rifles. In addition they construct a variety of traps like *binjivan* and *kathari* snares like *kudukku* or *kanni* and nests - *bale* which are used to catch most small game animals.

Fishing is done in small groups usually by women and children mostly during rainy seasons when the river overflows and fill the nearby plains. They fish by many techniques like small nets, basket traps, hooks, bombs, poisoning etc. At times they catch crabs from the swamps, paddy fields and small streams.

Gathering in the forest is of great importance both as a means of obtaining food and also as a source of raw materials. A considerable portion of the diet comes from the roots, tubers and green leaves. Mushrooms are highly desirable and are found in limited quantities and picked during the rainy season. Collecting is done by both men and women. The roots and tubers collected by the Mudugas mainly includes *noora kilangu* (powder root, - *Dioscorea pentaphylla*), *savel kilangu* or *naaru* (thorny yam - *Dioscorea tomentosa*), *sole kilangu* (*Dioscorea sp*), *kavala kilangu* (*Dioscorea sp*) and *perukku kilangu* (*Dioscorea sp*).

The only tool used for collecting roots and tubers **is** the digging stick. Digging stick known as *baji* **is** made using the small branches of trees especially *kauri* (*Helecteris sora*) and sharpened at one end and stripped of their bark.

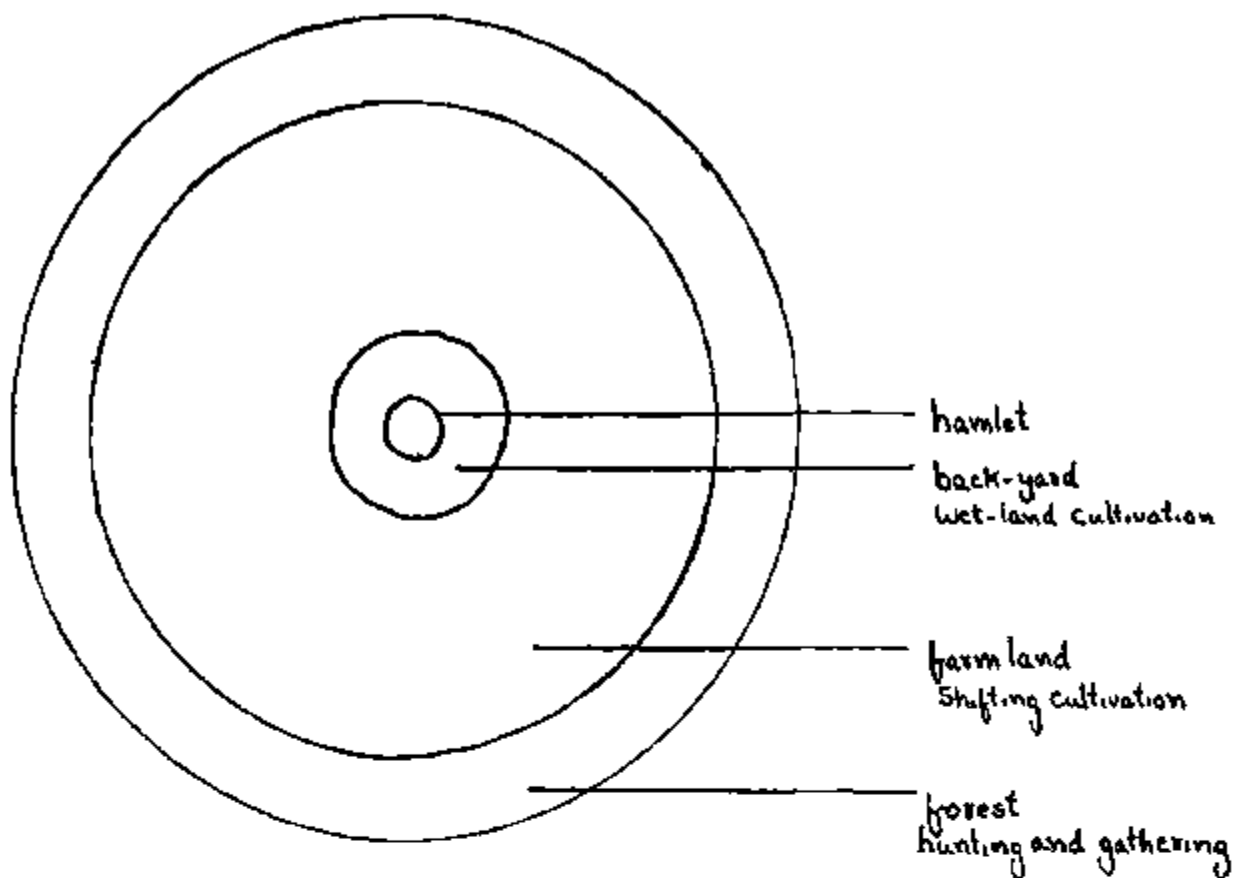

Fig 2. 5 Diagrammatic representation of hamlet and its surrounding territory

Forest products like bamboo, reed, grass, vines, wood etc , are used to manufacture household items like baskets, containers, brooms, tools and for constructing huts Medicinal herbs and roots, honey, bees wax, resin, bamboo, timber etc , are forest products used mainly for trade in the market The Mudugas identify four varieties of honey bees They are, *kolen then* (3.5 mm small harmless bee - *Melipona iridipennis*), *komban then* (8 mm long little honey bee - *Apis florea*), *thoduthi* (12 mm long forest bee - *Apis indicus*) and *karinthen* (large rock bee — *Apis dorsata*)

Among the Mudugas, ownership of land is collective, in the sense that all the descendants of a common ancestor are joint owners of the hamlet and its territory The descent group has the sole right over the land and is controlled by the council members Regarding right to land, it is not the absolute freedom of the individual or the family that

matters, but he consent of the council members especially the headman of the hamlet, Close affines when in need may come and reside nearby their wife's father, wife's brother or maternal kin and cultivate a portion of their land. In some cases, daughters use their father's land throughout their life time But they do not inherit it, and consequently, cannot hand it on to their children.

Nuclear family is the primary unit of economic production and a new unit will be set up on the marriage of each young man. Marriage among the Mudugas is characteristically an exchange relationship between patrilineal segments and they practice strict kin group exogamy They have a Dravidian — type kinship terminology and practice bilateral cross-cousin marriage Thus, a man is prescribed to marry a woman of the category *attai*, a category that includes bilateral cross-cousins (FZD and MBD), but covers all women of the same genealogical level as ego who belongs to different exogamic group Within this category of bilateral cross-cousin, no preference is expressed to either side According to the traditional custom there is no elaborate marriage ceremony and the couple are considered married when the girl starts living in the boy's hut Bnde-pnce known as *pariya-panam* amounting to Rs 251 VA is given by the groom's family to the bride's family

Mudugas are permitted to marry more than once and it is not uncommon for both men and women to have a succession of two or more spouses one after the other in their life time However, they do not maintain more than one spouse at the same time Although endogamous, Mudugas intermarry with their neighbouring group Kurumbas too with whom they share a large number of basic cultural features in common

The Muduga religion is based on ancestral belief and worship with the elements of rituals and ceremonies It is the ancestors whose benevolence and protection they invoke by regular offerings They have ardent veneration and fear for their ancestors who are their best protectors and assist them when they are in need and difficulties The ancestral god is commonly called as *karudaivam* and is also referred by the kinship term *pattern*, meaning great grand-father The ancestors are propitiated at the time of sowing (*hethe idurathu*) and harvest ceremonies (*thodu*) officiated by the *mannukaran* (man of soil) who is the formal priest of the descent group and the hamlet Failure of proper

worship and offerings to the ancestors, they believe, will result in famine, low fertility of soil, low production of crops, diseases etc.

The Mudugas believe in the concept of a "supreme god" above all the other ancestors which is supposed to have diffused from the Hindu tradition. This supreme god referred generally as *sami (sivan)* is believed to be the creator of all men and the universe, and have an important role in their mythological and religious concepts. The Mudugas have adopted Him in their pantheon, and endowed Him with the tribal qualities as *Kakki Linkan*, and his wife *Parvathi* with the name *Neeli*. It is to be mentioned here that, Mudugas are not worshipers of *Krishna* and never visit the *Ranganathan* temple, at *Karamadai* near *Coimbatore*, a famous pilgrim centre of Lord *Krishna*.

The Mudugas visit the *Melleswaranmudi* (hill), which is the abode of *sami*, once in a year on *sivarathri* night and light lamp and offer lengthy *pooja*. The *mannukaran* of *Thaze-Abbannoor* hamlet situated at the foot of this *Malleswaranmudi* is having the right to perform the ritual, and hence he is also known as *malapoojari*.

Every hamlet has a headman called *moopan* who is also considered as the formal spokesman of the hamlet. He is assisted by a *bandari* and a peon called *kuruthale*. All these three members along with the *mannukaran* settle disputes and matters regarding bride-price by forming a *panchayath* along with other elders of the hamlet and so contribute to the maintenance of social control and solidarity. All the four offices are hereditary in the male line.

The elder members play a dominant role both within the community and in its relation with other hamlets. It is they who arrange the marriage of their 'sons' and 'daughters' through discussions and negotiations. Very often one or more of the elderly men in the hamlet will be specialist in herbal medicine who cures illness, and a diviner or exorcist (*pattukaran*) who identify the cause of disease with the help of magical spells. There are also sorcerers among the Mudugas who through black magic (*odi*) can bring sickness or death to an enemy. Most elderly men know something about the curing of minor ailments, but very few know how to cure serious illness and the requisite spells.

The Mudugas distinguish disease mainly into two categories — few ailments are believed to be due to natural causes (*nattu noi*), but many accidents as well as illness are considered due to the malevolent actions of sorcerers, witches or evil spirits (*kattu noi*).

The latter one is distinguished into three types - *odi*, *pilli* and *kattu*. *Odi* is considered as the sorcery done by other caste people like Kuravar, Pulayar and Parayar. *Pilli* is the black-magic inflicted on them by their own people and *kattu* is the malevolent actions caused by witches or evil spirits like *pichathu*, *gali*, *biyyu*, *geraga*, *thayi* and *thevva*

Though marriage and birth are not often marked by major ceremonies, among the Mudugas, death is often an occasion for elaborate ceremony. They bury their dead and once in 40 to 50 years, elaborate dry-funeral (*bara-savu*) is held when the bones of the deceased are unearthed from the grave and after prolonged obsequies are buried in the rock cave called *gobbe*

Much of Muduga behaviour is patterned by rules between type of kin categories and between kin groups. The kinship system manifest itself in their marriage pattern, residence pattern and in their economic pattern of exchange of labour and sharing of food. A Muduga individual has both responsibilities towards his kin and privileges he may expect from the same. These reciprocal obligations are more when they are more closely related.

Apart from a very few anthropological studies and passing references in superficial ethnological surveys, little has been published or written about the Mudugas. Unlike most other tribal groups of Kerala, the Mudugas came to be mentioned for the first time in Government records only in 1938. Twenty years later in 1958 the first anthropological work was launched 'among the Mudugas' by the famous anthropologist A Aiyappan, but his work was restricted to the megalithic survival among the Mudugas. After that, in 1959 Furrier - Heimendorf published a paper in *Man* dealing mainly with Mudugas hereditary friendship and inter tribal sex relations with the Todas of Nilgiris. Further, in 1962 A A D Louiz for the first time presented a brief ethnography on "Mudugar" in his *Tribes of Kerala* (1962: 193-196), where he gives a brief outline of their social organisation, marriage rules, death custom and religion. All these works were of introductory nature and after that "Mudugas" rarely appeared in anthropological literature. This made A Aiyappan (1969: 38) to express the need for an urgent anthropological research among this "little known tribe". Though, P R G Mathur, a renowned anthropologist of Kerala did extensive field work among the Kurumbas of Attappady, was little interested in the neighbouring tribe, Mudugas. But his book *Tribal*

situation *in Kerala* (1977) presents very little description of Mudugas. Similar was the work of Stephen Fuchs (1973). Later, few ethnologists like D B Kapp (1985, 89), Paul Hockings (1989), and Kamil V.Zvelebil (1981) did extensive research among the 'Nilgiri area' in general. But their accounts all have strong linguistic emphasis and contain only few references to the Mudugas. Other than these, no detailed and systematic study on Mudugas came out as yet. As such the Mudugas need to be studied intensively.

Notes ;

¹ Attappady Tribal Development Project

² At Thaze-Abbannoor, there are about six separate farm areas for shifting cultivation. They are *beetti dhotta kadu*, *ellakara kadu*, *nelhara kadu*, *thoonkara male kadu*, *thuvakadavu kare*, *vage sole kadu* etc

DESCENT IDEOLOGY AND ORGANIZATION OF LOCAL DESCENT GROUPS

Descent Ideology

The Muduga descent organization is defined by the patrilineal descent ideology in terms of a common agnatic substance inherited from their paternal ancestors. The notion of sharing and transmission of this agnatic substance across generation forms the basis of descent among the Mudugas. Social unit thus comprising of all members sharing a common descent ideology traced from a particular ancestor forms the descent group. Though people claim to be descendants of a particular ancestor, they however, could not trace their exact genealogy towards the founding ancestors, and clansmen believe that they were related as brothers and continue as 'brothers' into the future. The basic unit of kinship among the Mudugas, are the patrilineal clans and is known after the name of the particular founding ancestor and the clansmen refer to themselves as belonging to one *koottam*, meaning group. People also use the term *pattan kalu*,¹ meaning 'ancestor-leg,' to refer to the descent line traced after an ancestor. Thus when people say "*emma manji patron kalu*", it means that they belong to the descent line (leg) of the ancestor. Manji, and believe that all members who trace descent from *Manji pattan* belongs to one *koottam*. They may also use the term *makka* meaning 'children' to refer to descendants of a particular ancestor (clan members). Thus, "*emma palli makka*" means we are children (descendants) of *palli*.

Two or more patrilineal *koottam* who consider each others as 'brothers' group together to form a still wider kin group called *kulam*, whose members are not restricted to a particular locality, but are dispersed in different hamlets or *ooru*². Thus, among the Mudugas, it is the patrilineal *koottam* that is associated with a particular locality and tend to be localized giving rise to local descent group. Other than being a wider patrilineal group, the *kulam* has little functional value and there are no instances where its members aggregate forming a corporate group.

Among the Mudugas membership to descent group is **attained** through birth and the people do believe that the agnatic substance which is the essence and basis of their descent group, *koottam*, is inherited through the male parent. The notion of parentage is based on filiation, and the reckoning of genealogical link is given much importance when speaking of descent link or descent membership among the Mudugas. Through this male link, all members of the clan share the clan blood (*chora*) transmitted from the ancestor and it forms the basis of common identity and heritage among the agnates. Since members who are of the same clan share then 'same blood' (*ore chora*), people are prohibited from entering into marriage with women of the same clan who share the clan blood and they consider it as incestuous. The notion of same clan or *koottam* forms the core of Muduga kinship and is materially manifested in the physical substance (blood and semen) which is passed from father to child. This provides the conceptual basis for a system of patrilineal descent. Since children are borne from agnatic substance, they are assigned automatic membership to the father's descent group. The principle inherent in the transmission of clan substance from father to child is clearly depicted in their famous saying “*aiwai vannu vithu, awwai vannu kadu*” which means that father is the seed and mother is the land. Just, the way by which the genetic essence is inherited by the seeding or plant from the seeds, similarly the child also inherits the agnatic substance from its father and not from the mother.

There are controversies related to descent group membership or agnatic identity and the question of biological paternity. Ramanan lives in Thaze-Abbannoor hamlet along with his brother and old mother. Few members of Thaze-Abbannoor particularly Kaden and his close kin consider Ramanan and his brother as non-agnates and often claim that they belong to the *koottam* of kattakadu hamlet and not to *Manji pattan koottam* of Thaze-Abbannoor. They also trace an affinal link to Ramanan's father Kuppen. However, Ramanan and his family strongly deny this by claiming an agnatic status. Ramanan says that his FFM from Kattakadu hamlet was married to the elder brother of Chekidan (the then headman of Thaze-Abbannoor). But when she was pregnant, she was divorced by her husband and sent back to her natal hamlet where she delivered Mathan. Mathan married from the *koottam* of Karara hamlet and was residing along with his wife's relatives at Karara. But later due to a quarrel at Karara, Mathan left his wife and

came back to Thaze-Abbannoor and found shelter at his FyB, Chekidan's hut and stayed along with Chekidan. At that time Kaden's mother's mother (who was a widow) was staying at Thaze-Abbannoor along with Kaden's father **Mullan's** family. Chekidan made Mathan to marry Kaden's mother's mother and in that union Ramanan's father Kuppen was borne, who is thus MB for Kaden. Though Kaden claims that Ramanan is his MBS and hence an affine for the Thaze-Abbannoor *koottam*, Ramanan strongly argues that his father is Chekidan's elder brother's grandson and hence a true agnatic member to the descent group of Thaze-Abbannoor

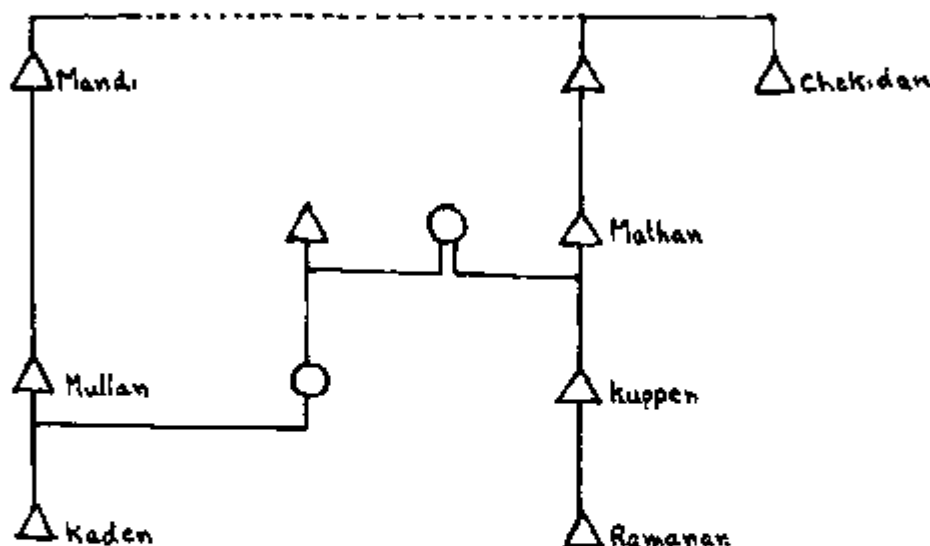

Fig 3 1 Genealogy showing relationship between Ramanan and Kaden

Another case regarding agnatic notion is that of Shanmukam who is the son of Chonoan of Mele-Thodukkı hamlet, but permanently residing at Chitoor hamlet. When Shanmukam's father died in his young age, his mother was married to Kalı of Chitoor hamlet and he also came to Chitoor along with his mother and was brought up by his step father. Shanmukam's mother in her second marriage with Kalı is having three sons — Maruthan, Pattı and Andı. Maruthan is the present headman (*ooru moopan*) of Chitoor

But Shanmukam is not at all happy with the decision of the agnates of Chittoor, ignoring him and making Maruthan as the headman, and he is now strongly claiming the position for himself on the base that he is elder to Maruthan. But the agnates of Chittoor are very much against Shanmukam's argument and are not at all willing to give the *moopu* (position of headman) to Shanmukam just because he is not an agnatic member of Chittoor but borne to a man of another descent group (see Fig 3.2)

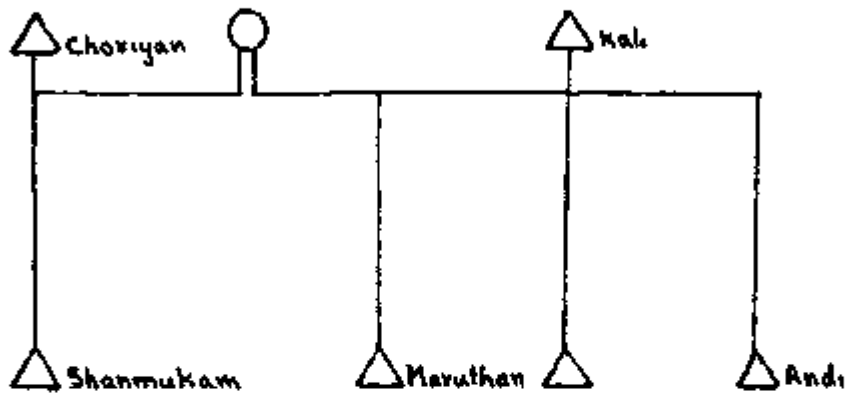

Fig 3 2 Genealogy showing relationship between Shanmukam and agnates of Chittoor hamlet

The above two cases clearly shows that among Mudugas, 'biological element' forms an important aspect and the basis for the inheritance of descent group membership. The descent ideology rests on kinship relations based on biological ties and hence considered as the core meaning of descent.

Though clan identity is built primarily on the natural fact of procreation, genealogical reckoning is not deep and people rarely could trace their exact genealogy beyond grand-parental generation. However members of a clan consider themselves related as 'brothers' and try to identify own brothers and classificatory brothers as culturally equivalent and seldom make a distinction. If asked, people say "*emma bahappa - sinnappa makka*", meaning "we are children of 'father's elder brother ~ father's younger brother"

The patrilineal descent ideology along with virilocal marital residence of the patrilineal kin forms the basic principle for the organization of local groups³. The local group or hamlet is called the *ooru*. A *koottam* is generally localised in an *ooru* or an *ooru* normally consists of agnatic members of a *koottam* and their spouses. Mudugas consider that agnates should live together, share land and food and also co-operate in important activities. Activities calling for collective action (mainly ancestral ceremonies, religious functions and other economic activities) are performed by the 'agnates as a whole' such that the *ooru* is conceived as a group of co-operative kinsmen. It is through these activities that a *koottam* residing in the *ooru* maintains unity among its members⁴. Property of the local descent group comprises the hamlet site, graveyard, farmland, water resources, hunting territory and grazing grasslands.

Although a large number of clan members are likely to be resident in a single hamlet, at times clansmen are seen dispersed in two or more hamlets, such that in most cases a single hamlet consist of at least members belonging to two or more clan. Descent groups among the Mudugas can be characterized as egalitarian such that all descent groups irrespective of numerical variations are of equal status.

The following are some of the *koottams* (known after the name of the founding ancestor) existing in the Muduga hamlets of Attappady

Sl No	<u>Name of the <i>ooru</i></u>	<u>Names of descent groups (name after their respective founding ancestors)</u>
1	Anakkal	Kozhi chellan, Parachellan, Vandichundan
2	Veettyoor	Kozhichellan, Parachellan, Vandichindan
3	Pottikkal	Alhraman, Manchi pattan
4	Mele-Abbannoor	Palli pattan, Benthathnal, Paccha pattan

5.	Thaze-Abbannoor	Manchi pattam, Killa pattan, Kurumba pattan, Paruthi mala pattan, Kozhichellan
6	Chindakki	Thevilinka Pattan, Mavilinka Pattan
7.	Chitoor	Paccha Pattan
8	Muthikulam	Sambar
9	Kallamala	Pooja Pattan
10	Karuvara	Paruthi mala pattan, Koliyankarar
11	Thundoor	Karikotta Pattan, Mala pattan
12	Veeranoor	Alliraman , Kalla pattan

Since the members of a *koottam* are not wholly localised in one hamlet and are dispersed in different hamlets, it is impossible to specify the numerical size of each *koottam*. Nevertheless, it is inferred that they differ among themselves in numerical size. However, these numerical variation has no direct proportion to status or power and among the Mudugas all members irrespective of their descent group and residential group are considered similar.

A person's primary loyalty is to his agnatic group and it is from this group he derives the greatest portion of his social identity. From elder members, he receives guardianship and care in his young days. He also receives rights to the resource of the land, a right to cultivate it, a share in them and other property, a house site when he marries, and other economic and ritual assistance on necessary occasions. With the people of his clan he lives, works and participates on public occasions and his kinship ties with them are recognized as being of a strong and close kind.

The descent group has the right over its members and individual choices are little, such that nobody can lead an independent life and live according to his own wish and will. Every member has to abide by the norms of his kin group and thus the norms of the society, and go according to the decision taken by his elder agnates. It is the agnates as a group who take decision and carry out important matters for their clan members in each and every stages of their life. When people often say "*mannukkum pennukkum sethan naalal thuna bedam*" (to unite with earth and women one needs support from people), it

clearly shows that life cycle rituals especially death and marriage ceremonies are occasions when one cannot do without the support of his close agnatic members.

Members of the agnatic group associated with a given locality tend to reside in the land owned by their clan and inherit rights to use spatially fixed resources and to cultivate the land. All the members of the *ooru* tend to do cultivation in one area and after two or three years when the fertility of the soil reduces, they shift together to the next plot and each member clears the land as much as they can, and do the farming independently. Close km select farm lands adjacent to each other for reason of co-ordinated group activities at the time of clearing, sowing, weeding, watching and harvesting. Except huts and farm lands under cultivation, which are private property owned by individual family, all other areas belong to the descent group as a whole and members have equal right to the resources of the clan's territory. Land which is 'fallow' is not owned by anyone. All the members enjoy equal right to land for grazing cattles, collecting roots, tubers, fruits and other resources. There is no restriction regarding the collection of roots and tubers and people are free to dig them out from anywhere, even from any farmland, but without causing any damage to the crops.

Strong relationship exist between patrilineal descent and land among the people. Men marry and establish their families remaining in the locality of their fathers. Such that, a patrilineal local group develops and persist through the generation. The *ooru* and its land is the domicile of the patrilineal descent group and this agnatic descent group traditionally own this territory. Thus, local group or the *ooru* is primarily a descent based group, because both descent and residence are recruitment for local descent group membership. It is often a co-operative group with common interest and joint action for organising ceremonies and conducting its affairs.

The hamlet or *ooru* acts as a corporate group of a political kind. Residence in the *ooru* implies political allegiance to the local group associated with a particular descent group or *koottam* in whose name the hamlet is organized. The *ooru moopan* or headman is the political leader of the hamlet and manages the affairs of the people residing in the hamlet. He is also the head of the traditional tribal council in the hamlet (*ooru panchayath*) and he is supposed to have authority over the members of the hamlet. Thus all the coresident members of the local group or the hamlet, irrespective of descent

affiliation, maintain similar identity of locality and are considered full members of the hamlet (*oomkarar*) It is through the jurisdiction of *ooru moopan* that the *koottam* exercise control over its members and also the co-resident nonagnates,⁵ treating them as sharing similar identity through locality, and thus all the members of the *ooru* are obliged to abide by the rules and norms of the *ooru moopan* All matters of significance like land disputes, fightings, and quarrels, thefts, elopements, adultery etc , are brought to his notice by the assistants (*bandari and kuruthala*) and the judgement will be made by the *moopan* The guilty one is found out after a prolonged deliberation in a joint meeting of the council members of the *ooru* headed by the *moopan* This meeting is known as *panchayat koodal* or they refer to it as *kalam bethu nayam peshi theerkal* Settlement of issues related to family quarrel or adultery are termed as *alan-pendunayam peshi theerkal* The victims are asked to pay a fine proposed by the *panchayath* members and the amount of fine varies according to the degree intensity or of the crime The amount collected as fine will be shared among the *panchayath* members or will be used for a common purpose by the *oorukarar* (hamlet members)

Ooru moopan is considered as the formal spokesman of the hamlet for outsiders and his more important duties are the protection of the rights and interest of the members of the hamlet No important affairs of the hamlet are carried out without the *moopan* and he is always informed and consulted well in advance In almost all occasions like marriage, death and other ceremonial functions, his presence and participation lends authenticity to the ritual and ceremonies The authority and power of exercised by the *ooru moopan* keeps the members of the local group closely connected and makes for the better ordering of human relations Referring to the responsibility of the *moopan*, people do say "*ooru pathu kudi kootti pidikira kadame moopanthu*", meaning that it is the responsibility of the *ooru moopan* to hold together the families in the hamlet An insoluble conflict or quarrel may be the occasion of a family migration or schism in the group It is the duty and obligation of the *moopan* to settle the issue and assure group solidarity, cohesion and a feeling of oneness among the members However, it is to be mentioned here that, the *moopan* though a sole authority in all matters, will be supported and always given advice and suggestions by the elder members of his *koottam* Even though *moopan* enjoys authority and power, it is restricted to specific occasions, and in

common everyday affairs, he is considered one among the clansmen and is treated equal in all aspects with all other members of the *ooru*

If *ooru moopan* manages the political affairs of the hamlet, it is the priest or *mannukaran* (man of land) who enjoys full right and control over the clan's religious matters and agricultural activities. He is the formal priest of the *ooru* and is considered responsible for the resources of the land, its fertility and the agricultural activities. All ceremonies and rituals connected with ancestral worship and other functions are performed by the *mannukaran* at the ancestor's hut (*peikoora*) which is believed to be the abode of their ancestors. The ancestor referred by terms like *karudaivam, pattan or pet*,⁶ are believed to hold a kind of control and guardianship over the descendants and protect them from diseases and disasters. All members of the clan owe allegiance to their ancestral spirits and are propitiated at all important religious functions. *Mannukaran* makes the offerings on behalf of the clan members both on specific occasions prescribed by custom or at an emergency following the request for such a rite by the members of the group whose well being needs to be assured.

Mannukaran's hut will be considered as the *peikoora* (ancestor's hut), where their ancestors reside and are installed in the inner room of the hut. The idol of ancestor made out of bamboo / reed or carved in wooden piece is placed in a clay pot (*pei satti*) along with dry grams of *rai* and *same*.⁷ These grams are said to be produced by their ancestors during their time. The grams are of ritual value so that during the first sowing ceremony, a little amount of these grams will also be mixed along with other grains by the *mannukaran*. In some hamlets, especially at Thaze-Abbannoor, the idol of the ancestor will be placed in big dry bottle-gourd known as *churakka*. In addition to these grains a handful of dry paddy grams which was believed to be cultivated by their ancestors at *mothakadavu*⁸ farm near kadukumannu *ooru* will also be kept along with the idol in almost all the *mannukaran*'s hut. The ancestral pot, *peisatti*, will be hanged to the roof in a secret corner of the inner room. However, the spirit and power of the ancestors exist in all huts of the clansmen and they believe that the power of their *pei* exist mainly near the kitchen hearth (*mathilu*) and bamboo baskets for storing dry grains (*gulume*).

Though every *koottam* is known after a particular founding ancestor and is considered as their major ancestral spirit, there are also other ancestors who are

worshipped and propitiated at the time of festivals and ceremonies. The people say that the latter stand in the relationship of classificatory agnatic brothers of their founding ancestors. But they are unable to trace the correct genealogical link between these ancestors. The name of ancestral spirits worshiped, including the founding ancestors, in four Muduga hamlets are as follows .

Thazeabbannoor *Manchipattan koottam* - Manchipattan, Killapattan, Eruve pattan, Kurumba Pattan, Baradi pattan, Sonka nathan

Meleabbannoor *Pallipattan koottam* - Pallipattan, Kunnia Pattan, Ganryapattan, Kulla Pattan, Sokki Pattan

Kallamala *Poojapattan koottam* - Pooja pattan, Thumma Pattan, Thanni pattan, Bhoomi pattan, Paccha Pattan, Sora Pattan, Bheema pattan

Chittoor *Paccha pattan koottam* - Paccha pattan, Nadappu pattan, Vanchinadu pattan, Mudavan pattan, Naga pattan, Maniya pattan

Ceremonies related to first sowing (*betha ideel*) and first harvest of crops (*thodu*) are occasions when the entire *ooru* jointly participate in the function as a single corporate unit. The *mannukaran* officiates the rituals connected with the agricultural practices in the *ooru* and he is expected to have adequate knowledge of the fertility of the soil as well as the seeds to be sown in particular season. The *mannukaran* select a particular date for the first sowing and first harvest and only after performing the ritual sowing of seeds by the *mannukaran*, the people start sowing in their respective farmlands. All the members residing in the *ooru* (agnates as well as non-agnates) are obliged to abide by the rules and norms of the *mannukaran* related to the fertility cycle. On all these ceremonial occasions such as *betha ideel* (first sowing), *soppu thodu* (first harvest of green leaves and first weeding ceremony), *rai thodu* (first harvest of rai,) and *same thodu* (first harvest of same), people participate together in the ceremony. Crops are not supposed to be harvested by anyone of the *ooru* unless the *mannukaran* performs the first harvest ritual of crops. On the *thodu* day, the *mannukaran* is having all right to harvest the crop from any farmland of the *ooru* to do the ceremony and to prepare food for the ritual offerings to the ancestral spirit.

Every member of the hamlet whether agnate or non-agnate using the clan land for cultivation has to abide by the rules and norms related to every calendrical agricultural

rites. Even if the non-agnates are residing in the farmland away from the hamlet, they participate and celebrate the sowing and harvest festival on the same day along with the agnates of the hamlet. Their support and participation in these ceremonial occasions are made evident by cleaning the front-yard of their huts and plastering with cow dung and also by keeping away from all sorts of agricultural activities on that particular day.

Ancestral gods are thought native to the land and are worshiped by every member at every calendrical agricultural rite. They propitiate the ancestors to enrich the fertility of the soil and to ensure a good crop yields for the coming harvest season. These ceremonial offerings made to the ancestors (*pattan*) at the time of *thodu* and other festivals reinforce the unity and integration of the *koottan* through the synthesizing power of ritual. All the agnates will assemble in the *mannukaran*'s hut and participate in the ceremony headed by the *mannukaran*. Food made of *same* or *rai* (depending on the crop for which the *thodu* is performed) is offered in plantain leaves to all the ancestors. This is called *mattu vakkal*. After keeping the *mattu* in plantain leaves in several rows of seven each, the agnates assemble and the *mannukaran* will call their ancestors. *Mannukaran* addresses the ancestral spirits by chanting their name and are invited to accept their offering (*mattu*) and to bless them. A ritual communion follows the ancestral offerings. All the agnates can have a share of *mattu* offered to their ancestors, but non-agnates and women are not allowed to have share of the *mattu*.

The ancestors are clearly conceived to exercise an overall control and can influence for good or evil on their own descendants. People always assert that no harm or illness can befall them if their ancestors are watchful enough, for they have power to ward off all evil and misfortune. Ancestors are appealed to and thanked for good yield, fertility of soil and all their fortune and success. In return, the ancestors safeguard community welfare. Ancestors are thought to be particularly sympathetic to the people and hold responsibility for the welfare of clan members. The desire to be remembered and given regular offerings is attributed to the people, and ancestral spirits may themselves cause harm and sickness to descendants who neglect them. Worshiping of clan gods gives the entire clan members a feeling of oneness and functions to strengthen the notion of descent and brings an element of group solidarity.

Other than the *moopan* and *mannukaran*, the council of the *ooru* consists of other two position - *bandari* and *kuruthala*, who are assistants to the *ooru moopan*. It is the duty of the *bandari* in looking into the affairs of the people and informing it to the *moopan*. He acts as a mediator between the people and the *moopan*. *Bandari* is also referred by the people as *moonathavam* meaning 'thirdman', since he acts as a mediator in settling disputes among agnates of the *ooru*. In the *panchayath*, it is the *bandari* who proceeds with the case and it is his duty to find out the guilty after a prolonged deliberation. The *kuruthala* functions as a second assistant to the *moopan* and informs issues and other matters in the *ooru* to the *moopan*. The office of the *bandari* and *kuruthala* vests with the *Jathikal*⁹ i.e., non-agnates settled in the *ooru*. Particularly the *bandan* will always be an affine to the agnates of the *ooru* and act as third man and proceed with the case without showing any partiality whenever there is dispute among the agnates of the *ooru*. People often say that it is the duty of the *jathi* to pursue matters of disputes and arrive at a peaceful solution.

It has been discussed already that in an *ooru*, the *moopan* will have the political power and control over all the residents of the hamlet irrespective their clan affiliations. In other words the authority of the *moopan* cut across the clan boundary and he is considered as the headman of the local group, the *ooru*, as a whole.

The *mannukaran* of an *ooru* though have a final say over all its residents utilizing the land and other resources of the territory in religious contexts especially with regard to ancestral worship, do not hold sole control over the entire *oorukarar*. But on the other hand have religious authority over and manages the ceremonial affairs of the clan members only. The co-resident non-agnates though join along with the agnates and participate in agricultural activities and other functions of the *ooru*, will detach from the agnates of the *ooru* with regard to their ceremonies and rituals and aggregate along with their clan members in their natal land.

Thus it can be said that the power and authority of an *ooru moopan* extends to the entire residential settlement / hamlet irrespective of the clan affiliation of its residents. Whereas, the *mannukaran* represents mainly the descent group and enjoys power and control over all its descent group members irrespective of their residence.

Patrilineal descent determines succession to status and inheritance to property between men and thereby continuity in the male line is stressed. Succession is through the male line, i.e., from father to son and the position of *moopan*, *mannukaran*, *bandari* and *kuruthala* are succeeded (primogeniture) by their sons. A man chooses his eldest son as his successor who has to continue his father's title and status and honour his father's debt and make good his bequests. The successor of the *mannukaran* should achieve knowledge about the ancestors, and prayers recited during rituals from his father and do offerings to the clan ancestors on behalf of the patrilineal descent group. Thus a vertical succession of titles and position is favoured among the Mudugas. However, on certain cases, when a man dies without a true successor or if his successor and heir is a small child, younger brothers will occupy the position. Sometimes in the absence of brothers, any other close agnatic member of the *koottam* will be given the position. This will be temporary for a shorter period until the real successor grew up, after which, he has to step down and the true successor occupies the position. At Thaze-Abbannoor hamlet, when Manchi *moopan* died, his two children were very young to take up the position of *ooru moopan*. Hence Manchi's classificatory father's younger brother Mallan was made the *moopan* of the *ooru* for a short period. Later when the children grew up, Mallan gave up the position of headman (*moopu*) and the youngest son chekidan was made the *moopan*. Since the eldest son Kakkai was staying away from the hamlet, he was not given the position.

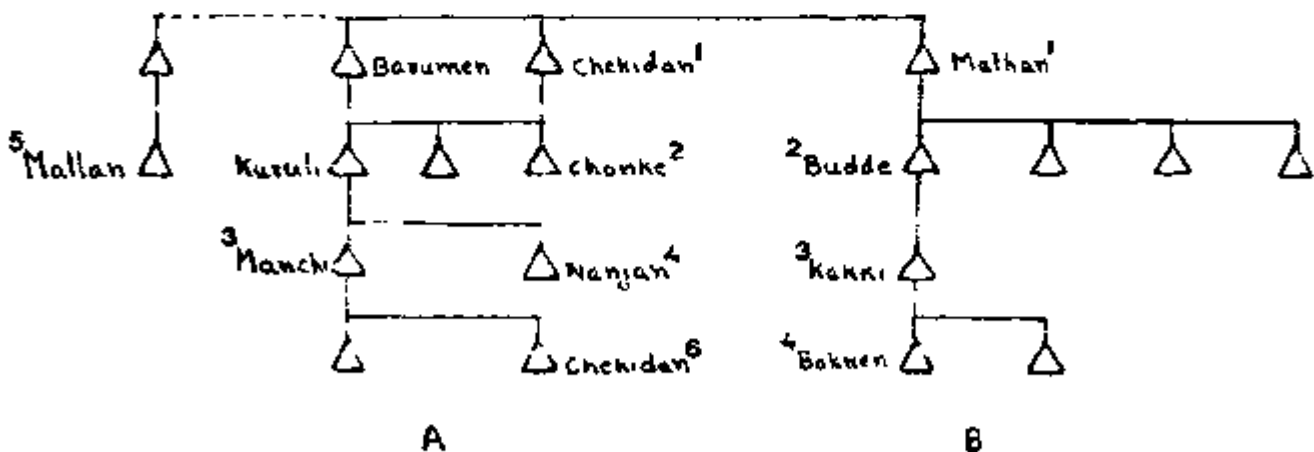

Fig 3.3 Genealogy showing the inheritance of a) *moopan* and b) *mannukaran* at Thaze-Abbannoor (numerals indicate the order of inheritance)

Though land is owned communally by the local descent group, families have right to clear the land, burn the bushes and cultivate it according to their capacity, and hence the land under cultivation is managed by families. Since land is available in plenty, there is no open competition among them for this and the notion of individual ownership is weak. Even now they consider it as wrong on their part to hold independent *pattayam* from the village office for their farmland. However, the land cleared and cultivated by the father will be inherited by the male children. Thus brothers have a common claim on their father's land. They or their sons take over the land cultivated by a brother who is having no children. Other properties like hut, cattles, agricultural implements etc, will also be inherited by the male children. Female children inherit ornaments and other personal belongings from mother and grand-mother. On certain cases married daughters and their children or immediate affines can reside in the *ooru* and a portion of their land with the consent of the *moopan* and the council members. This right to reside and farming of land is, however, not permanent, and in the event of any disputes and quarrel, they are forced to leave the land and the hamlet. A permanent alienation or loss of land to the outsiders is unconceivable to the agnates of the *ooru*.

Naming of children follows the patrilineal rule. Usually grand-parent's and great grand-parent's names are given to the children according to sex through a name giving ceremony called *peru pidishu athu*. The child will be made to cry while the elder members go on chanting the names of the ancestors one after the other to the child's ear. The particular name chanted when the child stopped crying will be given to the child.

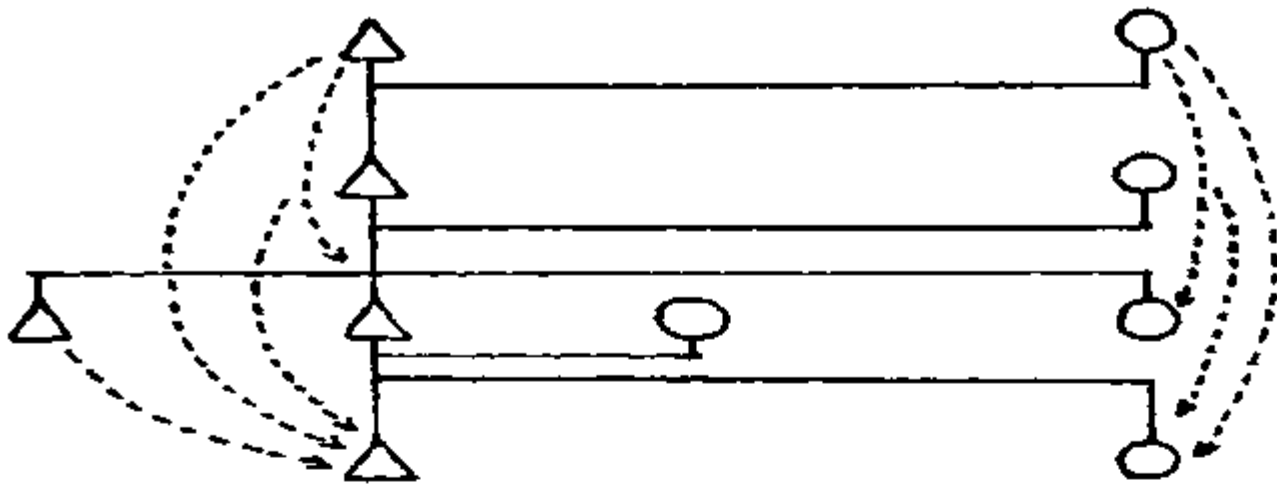

Fig 3 4 Pattern of inheritance of name

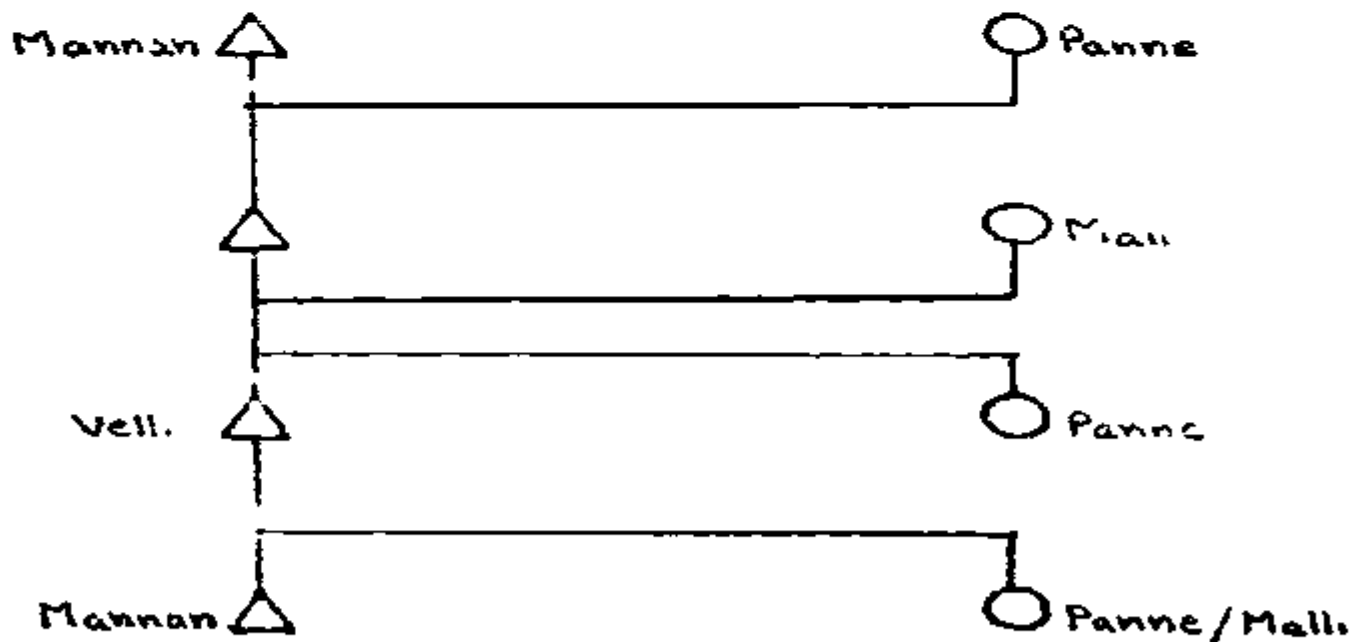

Fig 3 5 Inheritance of name in Velli's family

A male carries three names : name of the hamlet where he is permanently residing, his father's name and his personal name. For eg , a typical full name of a male Muduga reads Anakkal kuppen Man where Anakkal stands for his residential hamlet, Kuppen stands for his father and Man is his personal name

Organization and composition of local descent group :

The structural principle of patrilineal descent assigns the agnates with the right to reside on their clan land followed by a rule of virilocal residence. All clan members have the birth right to reside on their natal land where their ancestors have lived, died and buried. Men marry and establish their families remaining in the locality of their fathers such that a particular patrilineal descent group gets localized and persists through the generation. The *ooru* and its land is the traditional property of the particular descent group and its members whose ancestors were believed to be the founders. But this does not make for rigid membership in local group or exclusive use of land only by the descendants of the founders. There exists a disparity between the ideology of patrilineal descent and the composition of local descent group. The word *ooru* refers to units in which the 'property group' (though some members enjoy only usufructuary right in land) and the 'residential group' are congruent, i.e., having identical membership, and is organized on the basis of a patrilineal descent ideology. Ideally, the *koottam* and *ooru* should be coextensive¹⁰ such that the rules of descent, property, and residence are inextricably interlinked. However, due to various social and economic factors, all the members of a *koottam* cannot always form an exclusive property / residential group, and the members at times migrate to other hamlets becoming coresidents in that land. Agnation is the real structuring principle of local descent group and the people do have the notion that members should reside along with their agnates in their natal land and cooperate and participate with them in their economic and religious affairs. Local groups or hamlets are not restricted to agnatic descendants only. They are also permitted to kinsmen from other descent groups or *koottam*. Non-agnates and affines with the consent of their relatives and the permission of *moopan* become established co-residents, build huts, clear lands and cultivate and participate in the social events associated with the *ooru*. The nature of their residence,

land use, participation, and involvement shows that agnation is the primary but not the only means of membership in a local residential group - the *ooru*.

It should be noted that co-residence among the Mudugas **is** based on prior kinship bond and mere residence cannot create new kinship relation. Outsiders who are not at all related are never given membership **into** the local group as co-residents. Even **if** kinsmen are permitted as co-residents of the hamlet, the right to land **is** never considered permanent at any cost and the complete loss of land property to outsiders **is** objected by the **agnatic** members of the hamlet. If at any instance of disputes between the agnates and non-agnates, they are forced to leave the hamlet and seek shelter **in** their natal land. However, **if** a person uses **his** close affines' (MB, ZH or WB) land for cultivation and resides **with** them for a long period, **his** children also can continue cultivating the land which he has cleared.

These non-agnates residing **in** the local group enjoy right **in** the use of land and other spatially fixed resources of the natal group. The hamlet where people reside together, co-operate and interact **in** their everyday life **is** the residential group, and since descent forms the basic principle of organization, it can be said as a local descent group. **Nevertheless**, the agnates form the core group of the hamlet and most corporate actions are centered on this core group which **is** the 'dominant descent' group¹¹ owning the hamlet and **its** land traditionally from their founding ancestor. However, this dominance of descent group **is** not based on any status or power or the numerical size, but based on the traditional claim over the hamlet and its territory believed to have inherited from their ancestors who were the founders.

As long as they stay in a particular hamlet, they are said to be the full members of that hamlet or local group with regard to right to **in** the use of farmland and other resources of the local group¹². Thus **in** one case, Chellan of Karuvara hamlet, who has married the sister of Kakkı from Thaze-Abbannoor **is** residing along with **his** family at Thaze-Abbannoor in close interaction with **his** affines. Earlier, at the time of Chellan's marriage, **his** father-in-law, Budde had given **him** sufficient land to cultivate and wanted **him** to settle there at Thaze-Abbannoor. Now, Chellan's daughters were married to the agnates of Thaze-Abbannoor hamlet and are residing there at Thaze-Abbannoor itself. Moreover, Chellan's two sons also married from Thaze-Abbannoor and are co-residents.

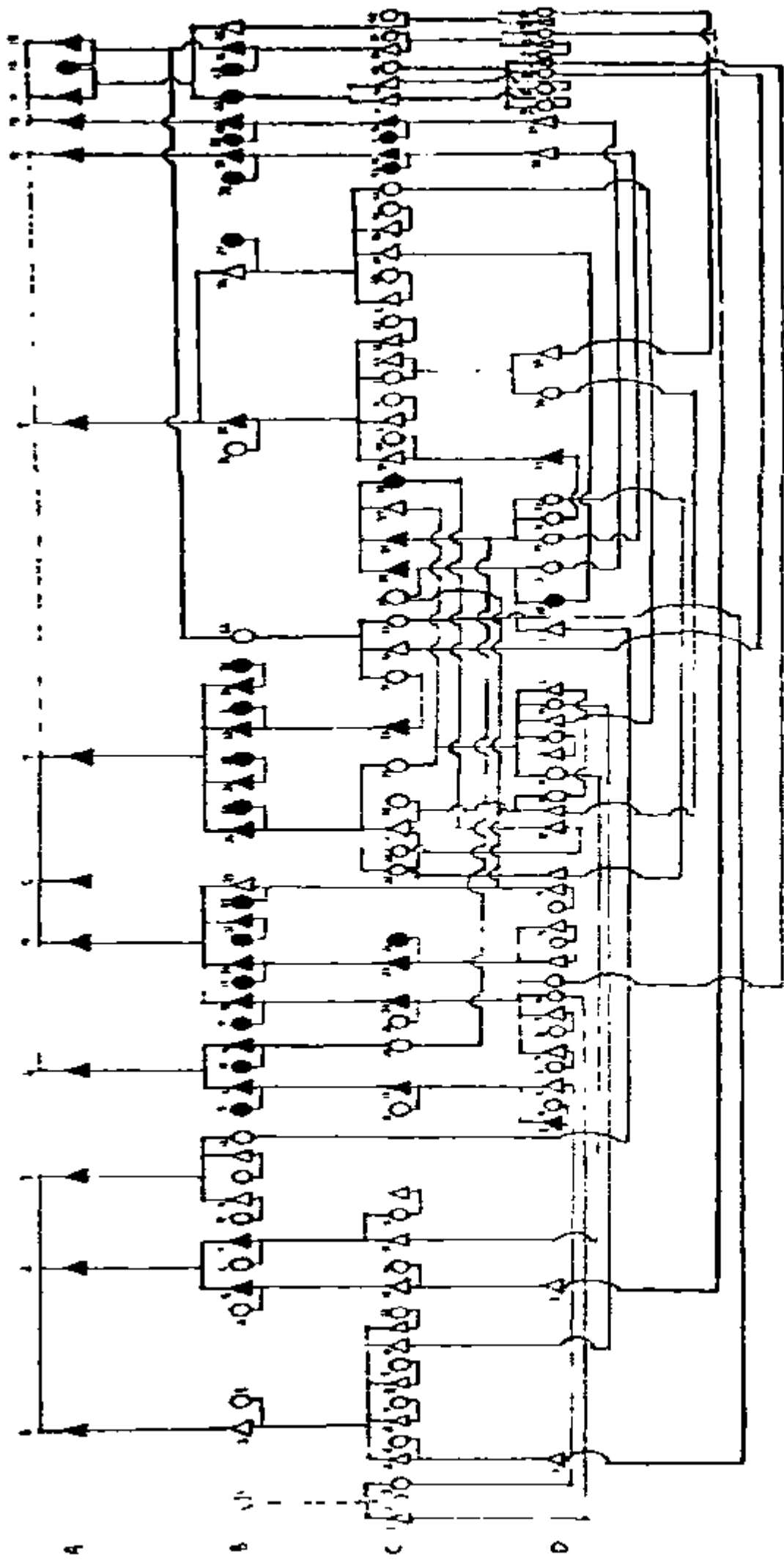

Chart showing the general composition of the valve assembly.

A B Feed Drive
 C D Control

Mathan's another grandson's (Mathan) (C30) wife Chelli (C31) who is a widow residing in the hamlet along with her younger siblings and mother Malli (B32) (who was married to Veetiyoor hamlet) Malli's brothers are Chatan (B44) and Nanjan (B 45) who are agnates to Thaze-Abbannoor, and Chatan's son **Panali** (C60) is followed by **his** son Murugan (D43)

Mandi's eldest son Mullan (B35) is having three sons, Kaden (C39), **Velli** (C41) and Panali (C45) and a daughter Vellachi (C43) mamed to Nanjan (C44) of Anakkal *ooru*, who is the *Kuuthala* of Thaze-Abbannoor Nanjan's daughter Beere (D34) is married to Kakki's son Murugan (D19) Mullan's younger brother Ooshi (B36) has three sons **Kali** (C47) Velh (C49) and **Churiyan** (C50) and one daughter Kuppe (C52) married to Panali (D24) and is staying in the hamlet

Three brothers **Karimen** (C35), Chatan (C36), and Chellan (C37) who have come and settled from Karuvara *ooru* represents the *paruthimalapattan* and are affines to Thaze-Abbannoor Their younger sister, Vellachi (C38) was married to **Kakki** (C27) (first marriage) and Kakki's younger sister, **Rami** (C29) was married to Chellan (C37) **Karimen** have one son, **Vella** (D27) and two daughters, **Neeli** (D28) married to Velh (C49) and **Vellachi**(D29) married to Man (D37) son of Choken (C56) After **Karimen's** death, his wife **Chathi** (C34) was married by Chonke (B23) and she is now staying along with him **Chathar** (C35) married Bokken's (B16) daughters Malli (C20) and their eldest daughter Vellachi (D30) is married to **Kakkihnkan** (D36) and younger daughter **Karimi** (D31) married to **Kaden's** son Ramaswami (D33) Malli (who is a widow) is now staying at Thaze-Abbannoor along with her daughters **Bokken's** (B16) and his elder brother **Velh** (B14) represents the *kilapattan koottam* at Thaze-Abbannoor Velh is having two grand-sons, Mathan (D3) and Bokken (D5)

The descendants of **Velh** (A1), **Kurumban** (A2) and **Veeran** (A3) represents the *Kurumbapattan Kottan* residing at Thazeabbannoor **Velli's** son **Mallan** (B2) have five sons, **Vellinkiri** (C4), **Maruthan** (C6), **Velli** (C8), **Enyan** (C10) and **Veeran** (C11) **Kurumban's** descendants are **Rangan** (C13) **Kali** (C15) and their sister **kurumbi** (C16) married to **Nanjappan** (C17) of **Pottikal** hamlet staying at Thaze-Abbannoor **Veeran** is having two sons, **Kali** (B9) and **Linkan** (B11) and their sister **Vellachi** (B12) married to **Vella** is residing in the same *ooru*

Kuruli's (B20) half-sibling, Malhan's (B18) son Kuppen (C22) married Ragi from Chitoor and he is now followed by Ramanan (D7) and Chellan (D9) Kuppen's two daughter's Mathi (D10) married to Kullan (C1) of **Mele-Abbannoor** and **Maruthi (D11)** married to **Chathi's** (C59) son Kullan (D41) are also residents of Thaze-Abbannoor **Kullan's (C1) mother Kurumbi (B1) is** also staying along **with him** at thazeabbannoor.

Nanjan's (B45) sister **Malli's** (B42) children, **Velli** (C57) and **Aiyappan** (C58) from Kattakadu *ooru* are also non-agnates residing at Thaze-Abbannoor **Velli is** the *bandari* of **Thaze-Abbannoor** and both **Velli** and Aiyappan have married Chathi's (C59) daughters **Chatu** (who was married to Mele-Abbannoor) **is** now staying along **with** her elder daughter **Nanchu** at Thaze-Abbannoor and her younger daughter **Laxmi** (B40) married to **Chellan** (C32) **is** also a resident of the *ooru* (Children are not represented in this genealogy)

An analysis of the numerical composition of Thaze-Abbannoor hamlet shows that out of the 48 married male residents, **21** belong to the main clan *Manjipattan kalu*, and 27 are non-agnates Of the 26 non-agnate males, 12 are in the affinal category and 15 are considered parallel relatives Among the 59 **married** female residents, 46 belong to other descent groups and 13 are agnates residing **in** their natal land itself Of the 46 non-agnate females, 8 were residents of the same hamlet before marriage The numerical composition of different descent groups at Thaze-Abbannoor according to the number of married males are as follows

Descent groups	No	of	married	males
<i>Manchipattan</i>			21	
<i>Kurumba pattan</i>			11	
<i>Killa pattan</i>			2	
<i>Vandichindan</i>			2	
<i>Paruthimala pattan</i>			3	
<i>Kozhichellan</i>			4	
<i>Palli pattan</i>			2	
Kattakadu <i>koottam</i>			2	
<i>All i ram an</i>			1	

The above statistics clearly shows that among the Mudugas, in addition to the agnates who form the core of the hamlet or local group, there are also non-agnate kinsmen recruited as coresidents into the local group who enjoy usufructuary right in land

The right which a person has to land in his own natal *ooru* differs, though not much, but in certain aspects from the rights he has to land in his mother's or wife's or other affines hamlet where he is a co-resident. In the hamlet where he is residing as a non-agnate, he has right only to land 'owned' by his close affines and he cannot as such cultivate any land anywhere as he wishes. He is having certain restrictions as to the selection and clearing of land, though not always but at least in the initial phase of his co-residence. In his natal *ooru*, he is not only having right to the land which his father owned, but if he needs more and is available, he has a right to clear the land he needs. On the other hand, in his affinal hamlet, he enjoys less freedom compared to his natal land and faces restriction in clearing any land he wishes. However, a long period of stay in the affines' hamlet clearing and cultivating the land gives him right and claim on land but not similar to that of the agnates of the *ooru*. This right and claim is only temporary, and moreover, this is with regard to use and not to anything else, and they can never be permanently inherited.

When patrilineal descent forms the basis on which agnates are aggregated together on their clan land, the non-agnates are recruited as co-residents on the basis of strong affinal bond or other matrilineal relations. The affines, even after generations of co-residence and holding of rights in land, remain identified as affines retaining their roles and obligations. It should be mentioned here that, this distinction or separation as affines and agnates forms the underlying structural principle of Muduga social system which is depicted in all their social, economic and religious activities. Thus, when the *moopan* and *mannukavan* who are agnates of the land enjoys the political and religious power and control over the members, it is the *bandari* and *kuruthala*, the affines of the land, who assist the *moopan* in discharging his duties, and the *bandari* functions as the mediator (*moonathavan*) in settling disputes among the agnates of the hamlet. Thus, this co-existence of agnates and affines and their mutual co-operation and symbiotic relationship forms the very basis of Muduga social organization.

The non-agnate co-residents are immediate affines only for a few members of the hamlet, and for others they are distantly related. But the kinship terminology could be readily extended throughout the *ooru* such that any two members of the *ooru* are in some category of kinship relationship to each other. Thus members of a local residential group are all related to one another. One can trace kinship to any other person either through a direct tie or through a third person. Within this local group, the links are definite and well known. The classificatory system of kinship terminology works in such a way that all the residents of the entire hamlet are divided into two major categories — *anna-thampi* category (parallel relatives) and *macha-maman* category (cross relatives). This classification placing all agnatic members into one category as 'brothers' represents their agnatic solidarity in all undertakings.

It is significant to mention here that, the co-resident non-agnates (who are not affines) after a long period of stay will be considered or given the status of *anna-thampi* category to the group with which they reside. However, they will not be fully assimilated into the agnatic core of the *ooru*. This points out the fact that, for non-members (strictly non-affines), co-residence for a longer period is a sufficient condition for this gradual conversion into the category of *anna-thampi*. The case of Mallan and his close kin reveals this aspect of change in status as parallel kin. Though Mallan and his relatives are permanent residents of Thaze-Abbannoor, their ancestors were originally from Kmnakara hamlet and they do not have any agnatic link with the core descent group of Thaze-Abbannoor. However, they are now considered as *anna-thampi* category by the agnates of Thaze-Abbannoor and are treated almost like agnates, even though not fully assimilated into the descent group. There is a myth which clearly reveals the coming of Mallan's ancestor *Kurumbapattan* to Thaze-Abbannoor and also showing how the *kurumba pattan koottam* got assimilated into the *anna-thampi* category.

During those olden period, Kurumba pattan and his relatives were well known for consuming buffalo meat. Beef was a major part of their daily diet such that they need at least one buffalo per day which they managed by stealing from the cattle shed of a nearby *Konkan* (local term for a Tamil group). When this became a regular practice, the *Konkan* realized that someone is taking away the buffaloes and decided to find out the culprit. One day the *Konkan* visited the Kurumba pattan's hamlet and found a small boy

whose stomach was full and heavily bulged. On asking the boy what was inside the stomach, he immediately **said** that **it** was full of buffalo meat. Realizing the culprit, that night the *Konkan* stood near the cattle shed **in** disguise, and when **the** Kurumba pattan came to take away the buffalo, he chased **him** back. Out of fear, that the *Konkan* would **kill** **him** for the theft he has already done, the Kurumba pattan decided to run from the hamlet. Thus he ran away from the hamlet to a distant place by carefully stepping on **big** rocks so as to escape from the *Konkan* following **his** foot-prints. He reached Thaze-Abbannoor hamlet and took shelter there. At that **time** the **wife** of Thaze-Abbannoor pattan saw **him** and she immediately went and told her husband that an unknown person had entered the hamlet. On asking about **his** details, he revealed the entire story without hiding anything. After listening to the narration, Thaze-Abbannoor pattan got convinced with Kurumba pattan, felt **pity** for **him** and allowed **him** to stay along with **him** in the hamlet. Moreover, Thaze-Abbannoor pattan assured **him** safety and gave word that he and **his** people **will** always be **in** **his** back for every affairs. From then onwards they lived as brothers and joined hands **in** all the **socio-religious** activities **in** the *ooru*. This relationship between the two ancestors are still **followed** by their descendants and is reflected **in** their ceremonial occasions when a member of the *Kurumba pattan koottam* join with the *mannukaran* of the *Manchi pattan koottam* in performing rituals during ceremonial occasions **in** the *ooru*.

The patrilineal descent rule and virilocal residence makes a person to reside in his natal land co-operating and participating along with his agnates. But at the same time it is to be mentioned that a person maintains close relationship with his mother's *koottam*, and links through mother are for some purpose recognized and important, though they are considered fundamentally different from links through the father. One makes frequent visit to his mother's brother and assist and help **him** in various activities. During olden days, if a man is proposed for his MBD, he has to stay along with his mother's brother and should do bride-service (*pennu-vela*) for his mother's brother's family for about three to five years.¹³ This long period of stay helps **him** to develop close relations with other members of his mother's hamlet and he also gets well acquainted with the land and its hunting and foraging areas. He erects a new hut nearby his mother's brother and starts his new family. At the same **time** he continues to do service for his mother's brother's family.

and will be assisted by his wife in all his endeavors. If there develops a strong intimacy between him and the members of his mother's brother's hamlet, he will be allowed to stay there as long as he wish. But usually after a penod of three to five years, he comes back to **his** father's place and reside along **with his** descent group members. Similarly, he **is** having right to stay along **with his** father's sister's family **if** he wishes to marry her daughter. Thus **it is** important to note here that **this** practice of long penod of bnde-service and stay in the **affine's** hamlet makes for the prevalence of co-residence of non-agnates in the *ooru*. Though people reside along **with** the members of **his** affme's hamlet for a long penod and develops close and intimate relationship **with** those members, and participate in all socio-economic activities of the *ooru*, he **will** not be assimilated **into** the agnatic group, rather remains as an **affine** to the hamlet and deliver the duty assigned for the *jathikal*.

When people due to certain economic as well as social reasons go and reside in their affinal land for quite a long penod, and fail to come back to their native hamlet for years, they cease to maintain any frequent social interaction **with** their clan members in their natal land. Nevertheless, dunng ceremonial occasions like marriage, death and ancestral worship, they are obliged to visit the natal land and co-operate **with** their agnates in carrying out the ceremonies. Though the day to day co-activity and participation **is** very weak, they try to sustain their agnatic link through these sporadic visits and co-operation and keep the tie renewed through generation and never let to break their **link** with the natal land. After a long period of stay outside *ooru*, usually people develop a sort of desire to come back to their natal clan territory (*jammam or seema*) so as to **die** and get buned in the grave yard of **his** natal hamlet where **his** ancestors rests. This desire is strongly expressed when they say "*emma vayasattu, ini emnnt ellum mullum emithu seemakku vannetheaom*" (we have become very old and now our bones should come to our natal land).

Kuppan of Mele-Abbannoor was staying uxonlocally **with his wife** at Boodar *ooru*. He had spent a major part of **his life time** at Boodar and married out all **his** daughters while at Boodar. When Kuppan and **his wife** became very old, he had decided to return to **his** natal land along **with his wife**. When asked, Kuppan replied that he was staying away from **his** natal land most of **his hfe time** and now **his time** has reached and

his only desire is to spend the remaining part of his life in his land, die there and get buried in the grave yard of his native *ooru*

Women who are sisters and daughters to the male members of the descent group are considered agnatic members of the descent group by virtue of birth. Until marriage, they stay along **with** their father and brothers **in** their natal *ooru* and participate as **full** members of the group. Through marriage women born to the group are given out to other clans, and women from other groups are taken **in** as “**wives**” and “daughter-in-laws”. Since a woman after marriage settle along **with** her husband **in his** natal land, she transfers her main worship to that of her husband's *pei-koora* (ancestor's hut) and the associated ancestors and joins **with** them **in** ancestral ceremonies and rituals. During marriage, the bride should first visit the *pei-koora* of her husband's group along **with** the groom and offer prayer, by which she is introduced to the ancestors of her husband's *koottam*. But it is to be mentioned here that, though women are married out to a different group, their relationship with their natal group never ends and at times when in need are eligible to use the land and residence **in** their natal *ooru*. Women are allowed to worship their ancestral god and to participate **in** the major ancestral festivals held **in** their natal land. This relationship becomes stronger and are renewed during these occasions where the married out women folk are obliged to come to their natal land and participate **with** their agnatic members. These married out women referred as *petta-pillai* (female children) are expected to contribute their share to the **bride-price** of their agnatic members and also for the *seeru* (dry-funeral) celebrations **in** their natal land as *petta-pillai panam* (female children's money). Even if she fails to attend the function, her son's are obliged to represent her **in** the function at her natal land and contribute the *petta-pillai panam* on her behalf.

According to rule, women are expected to **live with** their husbands **in his** natal land. But there are occasions when the couples opt to **live with** the **wife's** natal descent group. Convenience, preference, strong kinship obligations and other factors of personal choice are active forces which bring about **this** movement to affinal land. Married couples or families may use the farm land of their close **kin in** nearby hamlets for one or two years of cultivation. If the land **is** nearby to their residential locality, a shift of residence to the new **land is** not necessary. They can **work in** their farm land and come back to **their**

hamlet everyday. But if it is too far away for daily convenience, a temporary or long term move and the construction of new hut may be involved. After a period of stay in the new land, he and his family get adjusted with other members of the *ooru* and assimilated into the system becoming a functional part of the local residential group.

These tendencies may be illustrated by means of two cases. The first one is that of Raman of Anakkal *ooru* who has married Pariah's classificatory sister (father's brother's daughter) from Thaze-Abbannoor. Raman is cultivating a portion of his brother-in-law, Panah's farm land at Thaze-Abbannoor. Since Anakkal is near to Thaze-Abbannoor, Raman is looking after his farm land without becoming a resident of Thaze-Abbannoor. After the farm work, in the evening, he and his wife will go back to their own hamlet. But when the crops had matured and the flowering season started, he erected a small hut (*sala*) in the farm land itself and shifted his residence so as to watch the crops from birds and wild pigs. He stayed there for about four months till the harvest was over.

Similarly, Nanjan of Anakkal *ooru* who has married Ramanan's sister Chelli from Thaze-Abbannoor was doing farming in Thaze-Abbannoor land as a non-resident. Only during the final stage of the crop he erected a hut in the farm land, and stayed there with his family for three to four months until the harvest was over.

In yet another case, Velli who is a member of Anakkal *ooru* was cultivating a portion of the farmland of his wife's father Chellan, a non-agnate co-resident of Thaze-Abbannoor. During the initial stage of the cultivation, Velli was staying at Anakkal *ooru* itself and was visiting the farm land often. But later, he shifted to Thaze-Abbannoor and stayed along with his father-in-law Chellan. Still later in March 1997, he has erected his own hut nearby Chellan's hut and started his independent household. Now he has become a resident of Thaze-Abbannoor.

In certain other instances of frequent quarrel and family disputes, a woman separates from her husband and come back to her natal land to seek shelter in her father's or brother's hut. Later, she will be allowed to cultivate a portion of her father's or brother's farm land and can establish her independent household. Her younger children will be taken care by their mother's brother or mother's father who later develops authority and control over them. But this is temporary for a short period until the husband and his agnates approach claiming the right. Similar is the case if a woman becomes

widow in her early years of marriage. However, in both the cases the women tend to come back to her natal land if she is without bearing children or the children are of tender age. If the children are grown up and have established their independent household, the mother tend to seek shelter under them instead of going back to her father or brother.

Though agnates and non-agnates reside together **in** one hamlet for years and **co-**operate **in socio-economic** and political activities, difference of opinion do often arise between them and leads to conflicts and disputes. These tensions and conflicts **will** be suppressed to a certain extent by the tribal council leaders through *panchayath* meetings and prevent the explicit outburst leading to an apparent split. Under certain circumstances, these tensions lead to open conflict and end **in** the clear cut cleavage or fission of the two groups. If the dispute is between two *koottam*, usually the non-agnates are forced to go out from the land and seek shelter **in** their natal clan land or any other *ooru* where they have a strong kinship base. At certain times, the faction of non-agnates may split away from the agnates of the local group and establish separate residential unit a little away from the *mam ooru*, but **in** the same territory. They build up their new huts and **inturn** develops **into** a small hamlet. This split or separation **is** not only **in** the case of residence but can also be visible **in** the intensity of co-operation and participation in other socio-religious and economic activities. There are instances where the split away group do not observe the agricultural rites and other ceremonies along **with** the members of the main hamlet. Sometimes they may not recognize the status and authority of the council members of the main group and establish new council members of their **own**. In certain cases, the new faction may even seek the help of the council members of other neighboring *ooru* at the **time** of ceremonial occasions and *panchayath* meeting. Thus **Kaden** and **his** close relatives of **Mele-Abbannoor** hamlet are staying away from the **main** hamlet and have stopped all sorts of religious and economic interaction **with Mele-**Abbannoor after having heavy quarrel and clash **with** the agnates of the hamlet. Now that, for any important functions and *panchayath* meeting, **Kaden's koottam** are seeking the help of the *moopan, bandan* and other council members of **Thaze-Abbannoor**.

However, **in** most case, though the new group establishes their new residence away from the **main ooru**, and reduces the intensity of interaction between the *mam* group, they never form a fully autonomous group. They **will** still continue as part of the

main hamlet and consider themselves under the religious and political control of the main hamlet. They continue to cultivate the land and use resources of the same hamlet and its land. Vellara *ooru*, another split away section of Mele-Abbannoor, is a small hamlet consisting of **Chekidan**, his sons and close affine and **is** situated away from the **main ooru**, but **in** the territory of Mele-Abbannoor. Eventhough they lack frequent interaction **with** the **main ooru**, they consider themselves as part of Mele-Abbannoor and participate **in** all ceremonies along **with** the **main ooru** and are also under the political jurisdiction of the main hamlet.

Quarrel or conflict between individuals may develop **into** a form of group rivalry since each individual or family **will** be supported by their closest **agnatic** kinsmen. **This** may lead to a clear cleavage or fission **in** the hamlet. Disputes or quarrel can arise among agnates or between agnates and non-agnates residing **in** the same *ooru*. It **is** the responsibility of the *bandari* of the *ooru* to interfere **in** this matter, bringing it to the notice of other council members and settling the dispute through *panchayath* headed by the *moopan*, and preventing the conflict **in** reaching **into** a split. Disputes are caused due to individual fights, property damage, claim for religious right, right regarding farm land, marriage issues, adultery etc. When the conflict **is** between two different groups or between two separate *ooru*, the mass involvement **is** **high**. The incident arouses suppressed hostilities and the entire group members aggregate **together** for an attack. On these occasions there **is** no evaluation of rights or wrongs, the other **side** **is** the enemy, attacker or guilt and the mass action **is** **in** revenge for many past injuries, insult, losses or sorcery and the aim **is** to chase out the enemy from the land.

The term *ooru* has often a residential and not an exclusive descent connotation. Even non-agnates who are residing permanently for a long period **will** be known after the name of the hamlet where they are residing as *oorukarar*. If asked about their clan or descent group, they refer to themselves as members of so and so hamlet where their father belonged as agnatic member. People say, “*emma kattakkadu kaarar, ennu appanthu jammam vannu kattakkadu*”, (we are kattakkadu people, kattakkadu **is** my father's natal land)

Nevertheless, there **is** an agnatic core to the hamlet community and **this** core **is** the dominant descent group which owns the hamlet and **its** territory. Since all the members of

a clan never reside together or aggregate into a local residential group and agnates go out and live in other groups, all the clan or *kootam* members always cannot gather and co-operate together in all their economic and social activities. Descent members collect together as corporate unit only during ancestral festivals and other ceremonial functions. These are occasions when the notion of agnation culminates and descent members abstracted out and thereby depicting their group solidarity, cohesion and unity. Evans-Pntchard has correctly emphasized this aspect of descent for the Nuer when he writes, "in daily contacts between persons within the community their relations are expressed not in the language of descent structure but in the language of the kinship system by reference to categories of kinship within that system" (1951: 23). Thus among Mudugas descent members are articulated as groups of agnatic km at a different, usually ritual level of social life.

Operation of descent ideology _

Though the actual behaviour pattern of the people deviates to a certain extent from the ideal rule or structure and appears to be 'loosely structured' with regard to the composition of local descent group, it is important to note that, there is always a clear, consistent and deeply rooted descent ideology (descent construct) of the people which operates when the notion of differentiated agnation becomes crucial and thereby descent members are clearly differentiated and separated out. We will now look into some of these aspects.

We have seen divorced women returning to their natal land along with their children. In such cases, the children will be taken care by their mother's father or mother's brother and they establish control over the children and may even claim for the bride-price of the female children. However the patrilineal descent ideology operates and becomes crucial. Such that, the right of the father over the children never cease, but remains, and he can retain the right on paying an amount called *saakukooli* towards the guardian for taking care of the children and bringing them up. They have a deeply rooted agnatic notion, such that the people never want to loose right over the children. In the absence of father, it is the immediate agnates of the child's father who take the

responsibility, and the entire right on the child will be with these close agnates who have the obligation to arrange the child's marriage

A father acquires proprietary rights in **his** children, and **his** children are accounted members of **his** clan if he makes the **full** marriage payment to **his** wife's relatives ¹⁴ But if he or **his** clan members **fail** to make the payment, then **his** wife's descent group 'can have' a right over the children. However, the people never allow to happen **in** such a way and the father or **his** agnates retain the right over the children by payment of **bride-price** to the wife's group. Here the lineal ideology of the descent group extends wider enough to hold its members within its fold, and never let the collateral principle to override. A person becomes a member of a descent group by ascription and **it is** the descent group which **is** having the right to claim him and the right **is said to lie with** the group as a whole. The claim on proprietary rights **in** the children **is** not an aspect of choice, but **it is** strictly restricted to the agnatic members of the father's clan which **is** established through **bride-price** payment made at the **time of marriage** or at a later stage or even at the **time** of the death of either father or mother.

The case of Chelli's children highlights the priority of father's agnates regarding the right on children. After the death of Mathan of Thaze-Abbannoor, his wife Chelh and her children are staying along with her brother Chellan (who is also residing at Thaze-Abbannoor) and are under his care. In 1996, due to the spread of cholera, Chelh's two daughters died and Chelh and Chellan received an amount as compensation from the State government. But some of the *oorukarar* questioned the right of Chellan in receiving the money, saying that the actual right of the money goes to Kakki, who is Mathan's classificatory elder brother. Moreover, **it** was Kakki who **paid** the *pariya-panam* (bride-price) of Chelli at the **time** of Mathan's death. They are of the argument that Chellan is only *mamam* (MB) for the children but Kakki **is** *bahappan* (FeB) and hence he is having the real claim and if at all Chellan needs some money, a small share can be given to him as *saakukooli* for taking care of the children after Mathan's death. (see Fig 3.7)

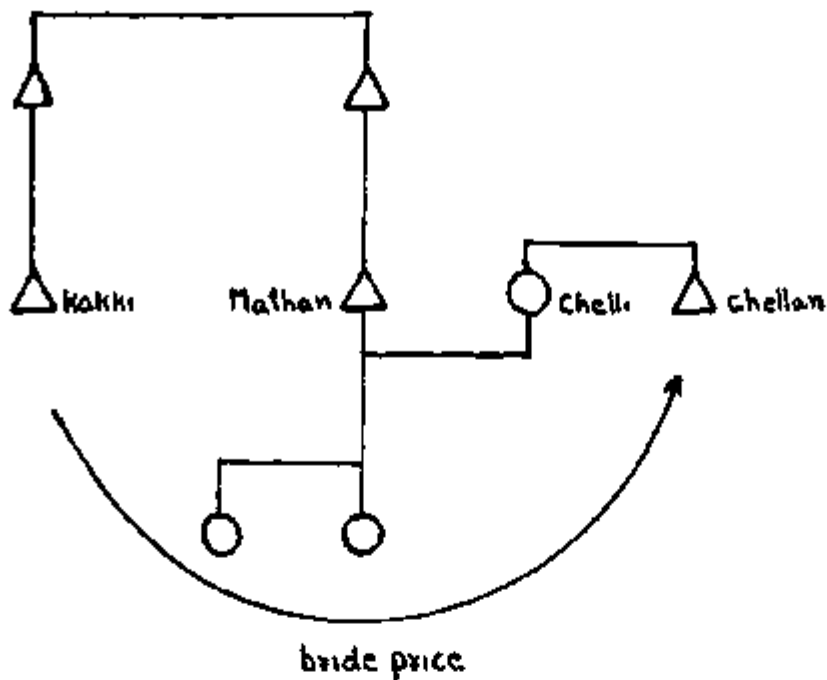

Fig 3 7 Bride price payment of Mathan

Even though non-agnates are allowed to stay in the *ooru* and live as co-residents for a longer period, one important aspect to be noted is that, after death, the body of the non-agnates will be taken back to their natal land for burial. But in certain cases, if the distance to his natal land is more and finds it difficult to transport the corpse, burial will be done in the graveyard of the hamlet where he was residing. An amount of money as *mannupanam* (land price) will be collected towards this from the close agnates of the dead. Even though the body of the co-resident non-agnates at certain circumstances was buried in the grave yard (*chudala*) of the *ooru* where he was residing, it will not be assimilated into the 'world of the ancestors' of the agnates of the *ooru* and their bones will not be pooled together or clubbed along with the agnate's during the dry funeral ceremony (*bara savu or seeru*). Instead, their bones will be taken by their agnates to their natal *ooru* at the time of their dry funeral, after paying a fee called *ellupanan* (bone price) and will be buried in the *gobbe*¹⁵ of his clan.

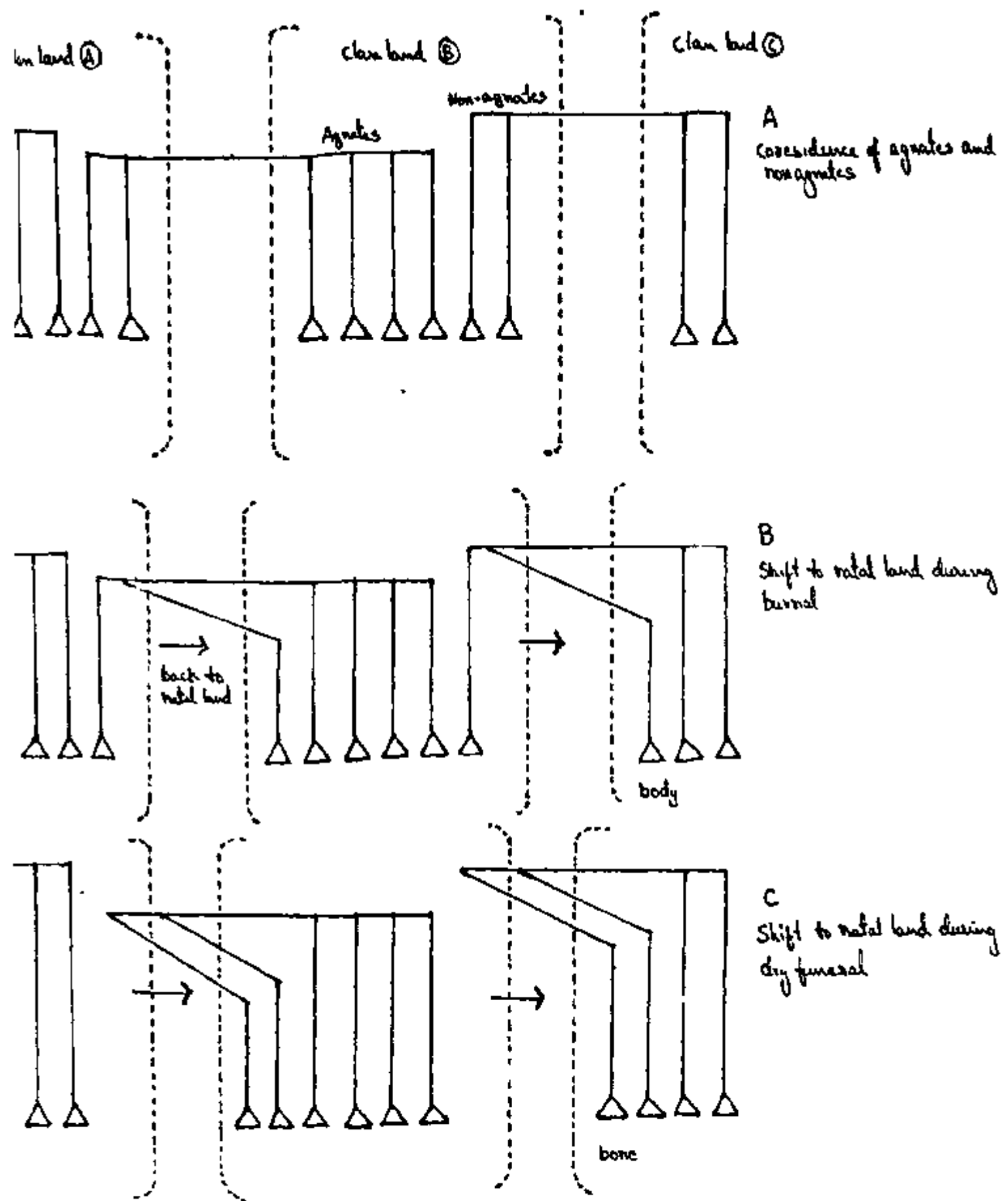

Fig 3 8 Co-residence of agnates and non-agnates and the shift of natal land during burial and dry-funeral

There are certain cases where the agnates fail to come at the correct time and claim the right of the body of their clan member who died while residing in other *ooru*. During these circumstances, the body will be buried in the graveyard of the hamlet where he / she was residing and the *oorukarar* will arrange the bride-price payment, if it is not paid on behalf of his / her agnates and thereby claim a temporary right on the deceased and his / her children till the actual owner comes forward. However, they have no right in assimilating the soul of the deceased with his / her ancestral spirits, which could be carried out only by their respective agnates through a ceremony called *nigal nokkal*.

A case in support of this is of Maruthan's sister Maruthan who is a native of Ommala hamlet married from Anakkal and is residing uxonlocally at Anakkal. His younger sister Chelli, has been named to Mele-Thodukki *ooru*. But after her husband's death, she came to her brother Maruthan and was residing at Anakkal. When Maruthan's sister died, nobody from her husband's hamlet came to pay the *pariya-panam* and to take back the body. Thus Anakkal *ooru moopan* who is also Maruthan's wife's brother, collected the *pariyam-panam* on behalf of Anakkal *ooru* and gave it to Maruthan, thereby taking the right of the children and the mother's body. The body was buried in the graveyard of Anakkal *ooru*. But however, the *nigal nokkal* ceremony was not performed by the Anakkal people. Anakkal headman, Kalamoopan says that even though they paid the bride-price and claimed the right, it is not at all permanent, they have only 'adopted' them and it is only temporary. He says, "*emma anakkalkarar makkane bakanju bachineru*" meaning, "we Anakkal people have just fenced the children". The children's father's *koottam* from Mele-Thodukki are the real owners and in future they will definitely claim right on the children and their mother's bone on paying the bride-price towards Anakkal people only. The agnates have the actual right to join her soul with the soul of their ancestors through *mgaal nokkal* which will be performed during the pacha savu (green funeral) ceremony at Mele-Thodukki.

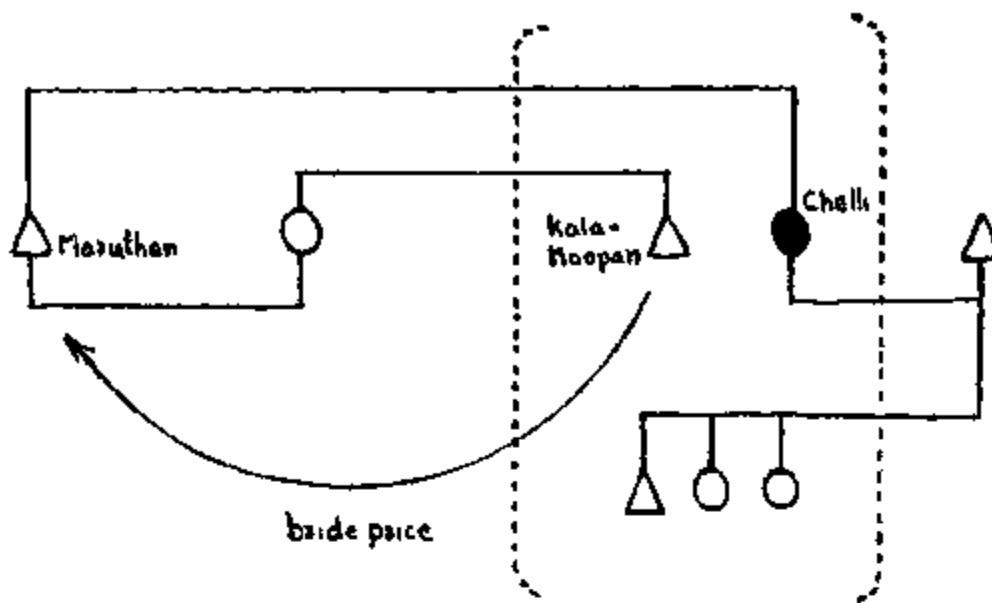

Fig 3 9 Temporary right on the mother's body and the children attained by *Anakkal ooru* on payment of bride-price

Now we will look into the process of *nigal nokkal* ceremony among the Mudugas which clearly depicts the sharp and strong agnatic distinction employed by the people through which clan members are separated out and assimilated into the ancestors after death

Nigal nokkal is a ceremony performed after the burial by which the soul (*nigal*) of the deceased is incorporated into the 'world' of ancestors. This is done by the elder agnates of the deceased and for a woman by her husband's agnates. After the burial is over, one among the close agnates, usually the eldest one will take two stems of *dharbha* grass (a wild variety of grass - *Poa cynosuroides*). One will be green representing the deceased and the other will be dry which represents the ancestors. After chanting the name of the deceased and the respective ancestor, the two stems will be dipped into the earth on the head part of the grave and will be taken back. This is called *nigal kuthi edukirathu*. After this, all the relatives gathered in the graveyard proceed back to the *ooru*. A measure (*padi*) filled with water will be placed in front of the particular hut by a close female kin. Those who have come back from the graveyard will gather round the

measure to perform the *nigal nokkal*. The *dharbha* stem will be made into small bits of about one inch length and after chanting the name of the dead one, the green bit will be put into the water, after that the dry bit will be dropped into the same water representing the ancestor. They then watch whether the two grass stems are coming close and join each other. If it gets joined, it shows that the particular ancestor has received the soul (*nigal*) of the deceased, if not, they assume that the particular ancestor is not receiving and will abandon that grass bits and repeat the procedure once again, this time in the name of another ancestor. Thus the procedure continues till the two grass come close and join together which symbolizes the union of the dead one's soul and the ancestor's spirit. In the case of a man, his *nigal* will be received by his agnatic ancestors like father, father's brothers or father's father. For a woman, her *nigal* will be assimilated with the spirit of her husband's paternal ancestors. The union of the dead one's soul with the spirit of a particular ancestor shows the 'nearness or likeness' of that particular ancestor and the deceased.

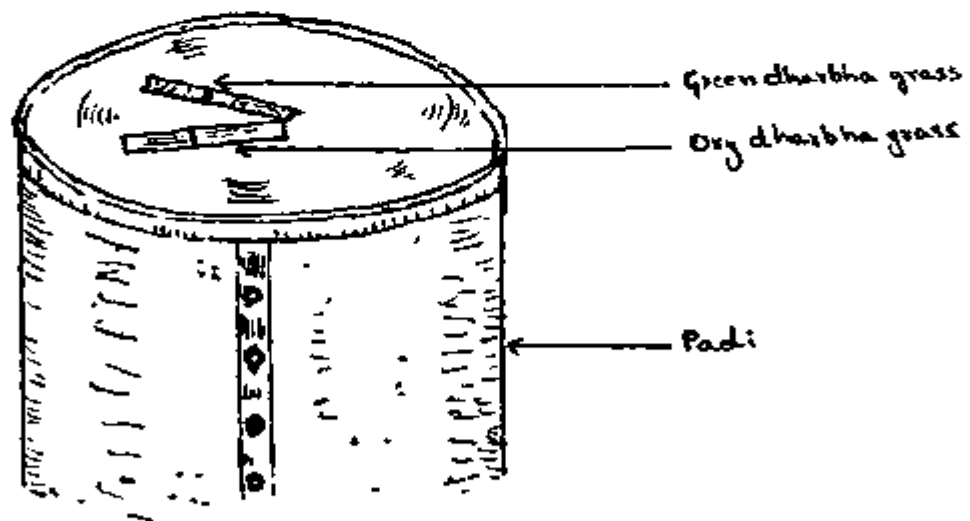

Fig 3 10 Performance of *nigal nokkal*

The bride price payment or *pariya-panam ketrathu* made at the time of marriage or at the death of either of the spouses or even during *seeru establishes* the right in the **wife** by her husband's descent group. Unless the *panya-panam* **is fully paid**, the husband's *kootam* do not have any right to bury her corpse and they cannot claim for her bone dunnung dry funeral (*bara saw*). Thus if the *pariya-panam* **is not fully paid**, the remaining amount **is paid** at the time of death or even later at the time of dry funeral and the right on the **wife** **is thus retained**. The payment of *panya-panam* (bnde-pnce) **is made** through a *panchayath* consisting of the council members of the hamlet and elder kinsmen of the husband and wife. Once the bride-price **is transacted**, the **bride's jathi** (third-man of bride's group) will take the hands of the children and mother and give it to the hands of the immediate agnate of the husband. This symbolically represents the transfer of right in the wife and her children to the husband's group. The significance and importance of this symbolic event **is revealed** through a case at Anakkal hamlet.

Dunnung the funeral ceremony of Kalamoopan at Anakkal hamlet, *Panchayat* was held for the payment of the remaining bnde-pnce. The bnde-pnce was paid by Kalamoopan's agnates to his wife's agnates from Thundoor hamlet. However, after the bnde-pnce payment, Kalamoopan's wife was seen crying aloud lamenting and cursing herself and was not able to control. Seeing this, her relatives gathered and tried to console her. When asked, she revealed that, after the payment of bnde-pnce to her agnates, nobody took her and her children's hands and gave it to her husband's agnates, to symbolise the transfer of their right to her husband's *kootam*. Moreover, she complained that, since this symbolic transfer of right was not enacted, she and her children was not properly accepted into her husband's *kootam* and feared that they may lose membership in her husband's *kootam* in future.

However, the elder members from both the hamlet tried to console her and assured that Anakkal *kozhichechellan (kurunagar) kootam* have taken the right on her and the children will take care of them without leaving them. This incident shows the strong and deeply rooted descent ideology of the Mudugas.

This payment of *panya-panam* recruits the **wife** to the clan's corps of ancestor spirits. In a sense it completes the assimilation of the **wife into** her husband's descent group posthumously. Before death, women are not fully assimilated **into** their husband's

clan and their status will be that of affines viz-a-viz her husband's group.¹⁶ Raymond Firth's remarks regarding the status of Tikopian women holds good here. Firth writes, "the best way of expressing her position **is** to say that on the one hand for formal privileges she remains a member of her clan, but on the other for economic and social **co-**operation she **is** included **in** the group of relatives of her husband (1965 317) This continuity of affinal status of women even after marriage could be very well depicted and justified **in** cases where women after husband's death are remained **into** the same *koottam* or clan

During the *seeru or bara savu*, the bones of the dead **will** be taken out from the graveyard and **will** be rebuned **in** the sacred rock cave called *gobbe* after performing a prolonged ritual for 3 to 4 days **in** the *ooru*. The bones (particularly the collar bones) of all the agnates buned **in** the grave yard since the celebration of the previous *seeru {bara savu}*, **will** be unearthed from the grave by their respective kinsmen headed by the *mannukaran*. The bones of the agnates who were residing **in** other *ooru* and got buned there **will** also be taken out and brought to the natal *ooru* for the obsequies. The first agnate to be buned **in** the graveyard **since** the celebration of the previous *seeru*, (no matter where he **is** buned, whether **in** the natal *ooru* or **in** the graveyard of the *ooru* where he was residing) **will** be considered as the 'founding corpse' (*thalakodi savu*). The name of this particular person, whether a child or a female, should be remembered by the *mannukaran* till the next *bara savu* ceremony **is** performed. By ntually addressing the name of the *thalakodi savu*, they believe that the spirits of the other agnates **will** also be assimilated together into the group of paternal ancestors and no clan member's spints **will** be left out even if they fail to dig out the bones or remember the names. Thus at Thaze-Abbannoor, the *thalakodi savu* for the next *seeru* **is** Panah's (C60) father's younger brother Naduvan's wife who was residing at **Anavai** *ooru* and got buned there **in** that grave-yard. Mudugas believe that the spints of agnates recognize each other and collect together **in** their natal land wherever they are buned which strongly depicts the agnatic integration of ancestral souls.

The *nigaaal nokkal* ceremony introducing the soul of their agnates **into** the fold of ancestors and the elaborate ceremony of *bara savu* which involves the digging of bones of agnates and burying it **in** the *gobbe* (rock cave) after several obsequies depicts a strong

and deep rooted patrilineal ideology employed by the Mudugas. These are ceremonial contexts through which their patrilineal descent dogma becomes more apparent separating out their agnates, and these **agnatic** concept transcends **into** and continues in the 'other world' also

A person's membership to a descent group **is** not based on the principle of **coresidence** and need not involve any individual choice regarding **his** descent group membership ¹⁷ It **is** the descent group itself which **is** having the primary right to claim **its** member, and the membership **is** strictly restricted **giving** no choice to the individuals. Thus according to Goodenough, "individual choice disappears when a person has a duty to be a member of a group or when a group has the right to claim **him** as a member. When a person finds himself as member of a group by **ascription** the right may be said to lie with **his** community as a whole, and **his** **is** the corresponding duty to comply with the community's rules" (1973: 59). Among the Mudugas, a person becomes a member of a group by ascription and it **is** **his** duty and responsibility to abide by the group's rules and norms. A person's descent membership cannot be changed because it **is** a part of the way the society **is** ordered. Fellow clansmen owe one another help and hospitality because they are the same **kind** of people. Beyond **this**, a person can extend **his** labour and loyalty to the members of the *ooru* with whom he **is** residing. Even though he **is** an operative member in another *ooru*, he does not lose **his** rights **in** **his** natal clan where he **is** thought really to belong and to which he almost always returns **in** a later stage.

It **is** to be mentioned here that though the non-agnate **co-residents** cannot claim permanent right to land and other **ritual** status, the non-resident agnates arguing from descent, retain permanent right **in** land and ritual authority as being descendents of the ancestor who **originally** owned the land. The co-resident non-agnates through their holding of usufructuary rights **in** land and participation **in** economic and social events with the agnates of the local group, derive an identity based primarily on locality. It **is** significant to mention here that, even after generations, the **ties** of co-residence **will** never be converted **into** the **ties** of descent, thus treating identity through locality and identity through descent as independent of each other. The non-members may only become **identified** as a separate descent group attached to the core descent group associated **with** the given locality.

Due to the dispersal of clansmen into other *ooru*, there always appear to be two kinds of agnates based on their residence and intensity of corporate activity. Thus there are agnates who are co-residents and who co-operate and participate in all their daily socio-economic affairs, and agnates who are non-residents and co-operate only during important and specific occasions like ancestral festivals. Since the second category of agnates rarely visit their natal clan land, their intensity of corporate action is weak compared to the former. At this point it is to be mentioned that like women who are dispersed to other clan land through alliance, men are also dispersed to neighbouring groups from their natal land. But there is always a difference between these two, because for women their membership in their husband's land is permanent and they are absorbed into the descent group of husband after death. But for males, their residence is 'temporary'¹ and are not assimilated into the agnatic group of the *ooru* where he is residing.

The living members of a clan are strongly influenced by their ancestors and there is always a sort of ritual contact between the descendants and the ancestors through the *mannukaran*. The ancestors are remembered, worshipped and offerings made by the clansmen in having an overall control and influence on their descendants and thereby the agnatic link is maintained and renewed through generation. Similarly, land which is another ancestral property is also controlled and influenced by ancestors by enriching the fertility of the soil and giving good yield. The land, trees, burial grounds, house sites etc., are associated with their fore-fathers (*Pattanar*) and ancestral spirits, and the fertility of the farm land and the yield of crops is associated with them. The burial ground (*chudala*), the ancestral hut (*peikoora*) and the second burial cave (*gobbe*) etc., become the dwelling places of ancestral spirits whose support ensures success.

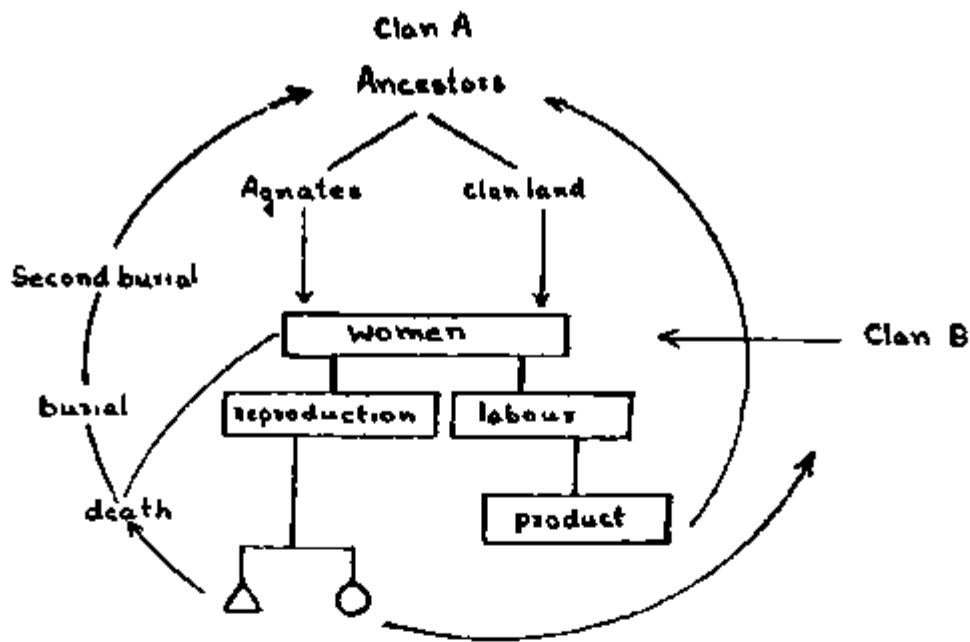

Fig 3 11 Cycle involving the regeneration of land and people

The natural cycle involving the regeneration of land and people is the domain of woman which expresses fertility. Thus the process of reproduction and production is presided over by women who have come from other clan land. The fertility of women provides the clan with sons and daughters. Likewise, the dimension of cultivation and the making of farmlands are the major responsibility of women whereby good yield is produced. Though a major portion of yield is consumed by the clan members, it is a product of land which is an ancestral property and hence it is reciprocated back through ritual offerings made to the ancestors. Similarly, the agnates live in the clan land, die, get buried in the clan's graveyard and their souls (*nigaa*) are taken back and assimilated into the ancestral world. Thus the cycle representing the regeneration of land and people is completed.

A long period of stay together by the agnates and affines will never make for the incorporation of co-resident affines into the agnatic core of the hamlet, rather a strict and clear distinction between these two categories is maintained which is depicted through their varied roles and obligations forming the basic structural principle for the functioning of the Muduga society, and this distinction endures through generation. Nevertheless, in relation to other outsiders, the entire members residing in a local group are referred as one in the name of the *ooru* as *oorukarar*. And, in daily contacts between persons within the community, their relations are expressed not in the language of descent structure strictly,

rather people consider each other as equals and distinctions are only made through terminological usages. Thus, in a general sense, when a hamlet is thought as a unit, it is not as an **agnatic** group but as a local group based on a particular descent group. However, reference to **clan** or descent group are made in context as to particularize an exclusive group of agnatic km in a different, usually the ritual level pertaining to the groups ancestors and associated ceremonies. This makes the descent members aggregate together as corporate unit through which the strong underlying principle of patrilineal descent ideology is brought out. Thus, discussing on the Nuer descent, **Evans-Pritchard** correctly points out, "it is the clear, consistent and deeply rooted descent structure of the people which permits persons and families to move about and attach themselves so freely, for shorter or longer periods, to whatever hamlets they choose by whatever **cognatic** or affinal tie they find it convenient to emphasize" (1951:28). Though in the actual behavioural level the Muduga local descent unit appears flexible and loosely structured, making people attain membership into any hamlet very freely, it is to be noted that on the other hand there is always a firm and deeply rooted descent ideology or 'descent construct' which helps to keep the structure of the society firm and avoid causing confusion or social disintegration.

NOTES ·

- 1 The term *pattern* refers to ancestors and also to the kin type- great grand-father
- 2 Some of the *kulams* found among the Mudugas of Attappady are *Kartika kulam*, *Bellaka kulam*, *Kuppa kulam*, *Armoop kulam*, *Kurunagar kulam*, etc
- 3 Goodenough (1962 1973) has emphasized the importance to differentiate between 'localized kin groups' and 'kinstructured local groups' and argues that anthropologists have always looked at residential groups primarily as kin groups and only secondary as local groups According to him it is common for local groups to be organized as descent groups rather than descent groups being localized
- 4 Among the Mudugas there are no evidence of totemic association of descent groups either towards any plant or towards any particular animal However, the Mudugas identify a particular variety of plant as *muduga thonda* (*Jatropha curcas*) though it has no significant ceremonial or ritual value This identity given to this particular plant is to distinguish it from another variety of plant of the same family, called *kota thonda* (*Ricinus communis*), the oil of which is believed to be a favourite item used by Lord Ranaganathan and so also by the Irulas, his followers, with whom the Mudugas maintain a strong social taboo
- 5 It is important here to clearly define and make distinction between terms such as agnates, non-agnates, affines and consanguines which are used in this thesis Agnates are members of a descent group sharing a common descent ideology traced from a common ancestor through male line Non-agnates are all those kinsmen who are not members of one's own descent group This category hence, include relatives both marriageable (cross-relatives) and unmarriageable (parallel relatives) Affines are persons related to ego by a marriage link and include kinsmen who are in marriageable relation Consanguineous are kinsfolk related by descent or filiation This category of kin also include parallel relatives and even affine's affine through the rule of terminological extension or kin classification

- 6 Though these terms are used simultaneously to refer their clan gods, there is slight variation in the sense and meaning *Pattan* is a kinship term used to refer great-grand father or ancestors, while the term *pet* particularly refers to God highlighting their supernatural quality *Karudaivam* is a general term used for clan gods by the tribal people of Attappady
- 7 Variety of millet (graminaceous plants) bearing large crop of small nutritious seeds *Same* is the common Guinea com (*Panicum millaceum*) *Rai* is *Eleusine coracana* or *Cynosures coracanus* much grown in India, Africa etc
- 8 According to Myth, there existed a farmland by name *mothakadavu* near *kadukumannu ooru* During olden period their ancestors happened to cultivate a variety of dry land paddy in this area The strange and powerful quality attached to this paddy is that, it took just only one day and one night for their ancestors to complete the entire process, i.e., ploughing, sowing, weeding, harvesting, and milling of the grains and getting it cooked The people attribute high ritual value for this paddy grains and they believe that an amount of this *mothakadavu* grains were distributed to every hamlet and they still preserve a handful of it in their ancestral hut
- 9 The term *jathikal* refers to affines, but it is used in a restricted sense for co-resident affines who participate and co-operate in most activities along with the agnates of the *ooru* *Jathi* is the singular form and *jathikals* plural
- 10 The custom of assigning the position of hamlet assistants (*bandari* and *kuruthala*) on the affines must have developed due to the practice of members becoming, as co-residents in their affinal hamlet
- 11 The usage "dominant descent group" refers to the original inhabitants who traditionally own the land and territory from the founding ancestors (also used by E vans-Pritchard 1951)
- 12 Keesing's account of the Kwai (1970) distinguishes between the rights of the agnates and non-agnates and argues that the agnates who are descendants of the founding ancestors have "primary rights" but the non-agnate co-residents have only "secondary rights" including use rights in the descent group's estate

- 13 Among the Mudugas, there is no terminological differentiation between patrilineal and matrilineal cross-cousins and both are equally preferred. Traditionally, marriages were through bride-service and it was performed for marrying patrilineal as well as matrilineal cross-cousins irrespective of their genealogical closeness. However, this custom of bride-service is not common now-a-days.
- 14 The major function of *pariya-panam* or *pennu-panam* (bride price) is not only acquiring of proprietary rights in children, but right in both the wife and the children together even if the payment is made at a later stage. These functional aspects of marriage payment among patrilineally organised societies have been emphasised by anthropologists (see Fortes 1962).
- 15 *Gobbe* is the small sacred rock cave where bones of the ancestors are buried at the time of dry funeral ceremony or (*bara-savu*) or the *seeru*.
- 16 Referring to Lewis's comparison of unilineal descent groups (Lewis 1965), Barnes (1967) remarks that the fact that women are not completely "owned" by their husband's group has been interpreted in two diametrically opposite ways — either as a sign of strong patrilineal descent, or as a symptom of weak patrilineal descent.
- 17 Firth (1963) has distinguished between "definitive systems" of descent, in which the individual has no choice of membership, and "operative systems", in which the individual has choice.

FAMILY ORGANIZATION AND DOMESTIC ACTIVITIES

After the descent *koottam*, it is the family which forms the basic and most significant unit of social organization among the Mudugas. It is the family which always takes the form of a household in terms of residence. However, anthropologists have defined family in terms of kinship relations and household in terms of residence and domestic activities.¹ According to this, in certain cases, households may be made up of individuals between whom no primary kin relationship exist, and conversely members of one family may be distributed over two or more households. Thus in the case of household, it seems more important to understand the activities that are central to the domestic relationship, rather than with the relationship between members as in the family.²

However, we may not find these units operating distinctly in many of the simple societies.³ Similarly among the Mudugas also families constitute households (residential units) and perform some set of activities – food production, consumption, sexual reproduction and child rearing (domestic activities). Since members of a family constitute one household and function as one domestic unit, these concepts are used synonymously. These aspects of composition and activities associated with the Muduga family and household and its development cycle will be dealt in this chapter.

The Mudugas have no special term as such to refer to the family. However, the word *kudumbam* is used, which refers to family as well as to closely related agnates when used in a broader sense. But they often use the term *koorai* which implies both the family and the household.⁴ *Koorai* gets its meaning depending on the context in which it is used. The word *koorai* has the meaning family or household and at the same it also refers to the dwelling or hut and further implies that every household will be in a separate hut or dwelling. When one refers to his family members, he would say “*ennu koorakarar*” Here the term acquires the meaning of a family. If one invites to his hut, he would say, *ennu koorakku bame* (come to my hut). Here the term denotes the dwelling or the hut.

Thus in general use, *kooiat* refers to the household members who live in a single hut, sharing a common cooking hearth, who pool their income and living expenses and cooperate in domestic activities

There is of course a considerable amount of variation the way in which the *koorai* is constituted and it is necessary to distinguish between the domestic aspects and the residential aspects to account for the variation. If division occurs in an household due to the marriage of a son, the new family may function as a separate domestic unit or household in a newly erected hut with their independent hearth, cooking and eating. Suppose, if this new couple even after marriage stays along with other members of his parents family in the same hut, they will remain as part of that domestic unit or household with a common hearth and cooking. Thus a single hut or dwelling never consists of more than one household or domestic unit and as long as members reside together under one hut, they form a single domestic unit cooking and eating together. But when a single hut cannot accommodate all the members of the household, especially at the initial phase of the marriage of children, they sleep in separate huts but functioning as a single domestic unit. Even if they dwell in separate huts, they will not establish their hearth and function as an independent cooking unit, but, will be eating with and cooking with the parents domestic unit in a common hearth.⁵ In such cases, they will be identified as a single household or domestic unit, cooking and dining together. Thus among the Mudugas, even if two separate huts share a common cooking hearth or work as a single commensal unit, will be referred to as a single '*koorai*' only.

Among the Mudugas, the simplest form of household representing a domestic and procreative unit is the nuclear family constituting a man, his wife and children, residing in a single hut. This nuclear family constitutes a single economic unit and its members are mutually dependent on one another for the production and consumption of food and satisfaction of other needs.

Though the ideal composition of a household is the nuclear family, households in certain cases include persons outside the nuclear family also. However, the membership to a household or a domestic unit will be strictly based on the degree of closeness to either spouse and thus restricted to close kin of either husband or wife. Hence, among the Mudugas persons who are distant relatives will rarely form members of the same

domestic unit. The composition of Muduga domestic group shows that far from being randomly composed, these groups tend in the great majority of cases to contain persons related in only a comparatively few ways through kinship and marriage. Persons related in certain ways only become members of the same domestic unit and persons related in any way cannot become members of the same household. Thus persons beyond the level of primary kin of either the husband or wife rarely become members of that unit. In very rare cases only distant relatives (i.e., secondary or tertiary kin) of the members constituting the nuclear family are attached to the household. Thus in one case at Thaze-Kakkupadi hamlet, Chathan's household, other than his wife and children includes his FZ Chathi, Chathi's widowed daughter Jakkī and her children, and Chathi's eldest daughter's daughter, who are not primary kin to any member of Chathan's nuclear family (see Fig 41)

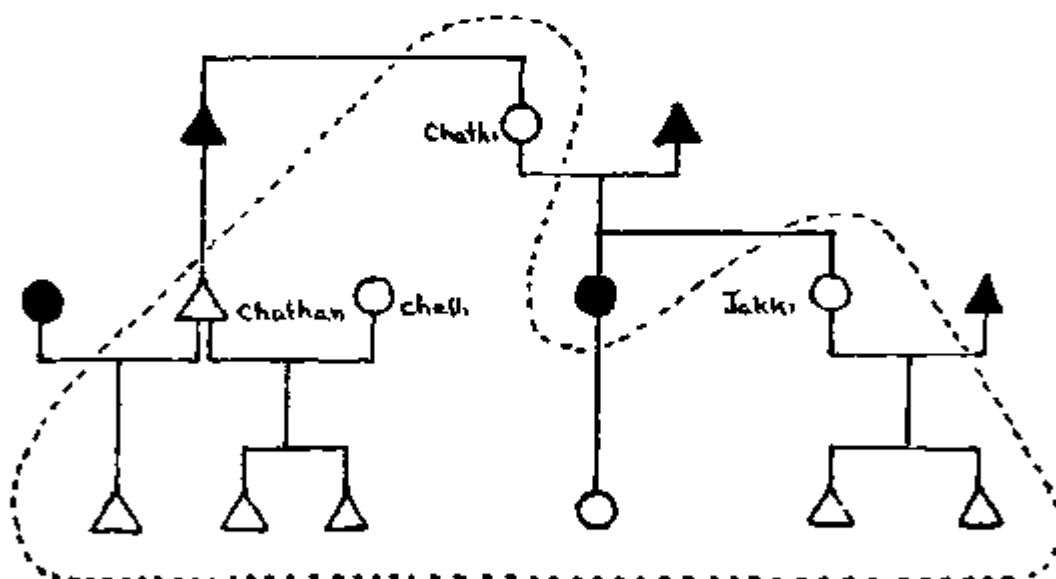

Fig 4 1 Genealogical composition of Chathan's family

Statistics shows that out of the total of 959 persons in the sample, 58 persons (11 males and 47 females) are either widowed or separated. From **Table 4 1 it is evident that** out of the 47 separated / widowed females, 17 are attached to the households of their sons and 15 are attached to their daughters. Among the remaining separated / widowed females six are dependent to their brother's, six to their parent's household, six to their parents, two to their brother's and one to MBS' household. When compared to females, the number of male persons who are separated / widowed is very less i.e., 11 in number. Out of this 11 separated / widowed persons, 5 are attached to the households of their sisters and one each to their brother's, parent's and unmarried children's households. The less number of separated or widowed males is due to the fact that they remarry much faster than females. Women after separating from her husband usually seek shelter along with her father or brother or stay with her grown up children. She will opt for remarriage only after some period of time, and that too if she is in her young age. But for a man, he usually go for another union much earlier, since he needs to look after the children and more over without the co-operation of a woman, he cannot have a fully functioning household or a domestic unit. Only men who are very old will keep away from remarriage.

Table 4 1 Widowed / Separated persons attached to household of Kin

	Relation with members of the attached household							
	B	Z	S	D	F/M	UM	BS	MBS
	children							
Females	6	-	17	15	6	-	2	1
Males	1	3	5	-	1	1	-	-

All the members of the household who are part of the domestic unit, irrespective of sex and age, take part in subsistence activities. They work together, enter in mutual

assistance, and share the benefits of their joint effort. Among the Mudugas, the simplest composition of an household to function as a domestic unit should consists of two abled members - a male and a female, capable enough to take full responsibility of managing the household affairs. Nevertheless, more than one married couple rarely form part of one domestic unit. Once married, the couple tend to establish their independent domestic unit separately in a newly erected hut. Though he stays **with his** parents in the early stages of his marriage, later he establishes **his** own independent household nearby **his** father's. There are cases where sons even after marriage remain **with** their parents as part of their domestic unit for quite sometime giving rise to a lineal joint family type **till** they establish their own independent household. If the hut **is** very small, **this** newly married couple may be sleeping in a separate hut but regarding cooking, **eating** and other domestic activities, they function together as one unit. **Kakkı's** son **Raju** of **Thaze-Abbannoor** after marrying **Vellachi's** daughter **Mathi** from the same hamlet continued as a part of **his** parent's domestic unit contributing their labour in the domestic activities, cooking and eating together. But later, the new couple shifted to a nearby hut mainly for sleeping in the night time. However, they continued as integral part of their parent's domestic unit cooking and eating together and thus forming a single commensal unit.

Among the Mudugas, though a typical household **is** of the nuclear family type, other forms of households such as the joint family type also do occur, but in rare cases. The term joint family **is** used to refer to a group of two or more nuclear families joined lineally by father-son bond or fraternally by the sibling bond. The former **is** called the lineal joint family and the latter the collateral joint family. A combined lineal — collateral joint family would be based on both the above forms constituting man, **wife**, married children along **with** their spouse and children. In some cases a widowed mother or sister may join a nuclear family giving rise to a paternal extended nuclear family type. And in yet other cases, a widowed sister **with** her children attached to the nuclear family of a brother give rise to a bilaterally dependent nuclear family.

This attachment of relatives to a nuclear family unit **is** primarily based on the degree of closeness, and relatives beyond the primary **kin** level of either the husband or **wife** of the nuclear family rarely become members of the same household or domestic group. More distant **kin** may occasionally be **accommodated**, but they remain attached for

a short period and later gets separated erecting a new hut and forming their own independent domestic unit. Usually these dependent relatives are attached by primary link through either husband or wife, and no distinction as such is made between **husband's** and **wife** relative.

Another important feature of the Muduga domestic organization is that a parent and child are mutually obliged to help each other subsist when either needs help. If the child is too young or the parent is too old, he or she must be supported as a dependent by the other. Thus ideally among the Mudugas a person should belong to a domestic unit including his / her spouse, parents or children. However there are cases, though rare, where people deviate from this ideal pattern and attach to the domestic group of persons other than his / her spouse, parents or children. The reason as to why these persons are not members of the same domestic group as their parents or spouse is mainly due to the death of the parents or spouse or separation from the spouse or parents.

Table of 4.2 shows that out of the total 959 persons in the sample, 39 persons who are either unmarried, separated or widowed are attached to households not including either a parent, child or spouse. Out of these 39 persons, 7 males and 8 females are attached to their brothers households and 8 males and 2 females are attached to their ZH household. The rest of the members are attached to the households of BS, MBS, ZH, MZ etc. There are no instances of a widower or separated person getting attached to the domestic group of his WB. This is because there is no primary kin for him in the domestic unit unlike in a ZH' household where his sister is a primary kin.

Table - 4.2 Members attached to households of other than parent, Spouse or Children

Relation with the head of the household

	B	ZH	BS	MBS	MB	MZH	FB	MMBS	MM	FZH
Males	7	8	-	-	2	1	1		1	1
Females	8	2	2	1	1	-	-	2	2	-

Types of families / households :

The different types of households based on genealogical composition present among the Mudugas of Attappady where household survey is done is shown in Table 4.3. The types of households include nuclear, lineal joint, collateral joint, hneal-collateral joint and various extended forms of the above mentioned households.⁶

1 Nuclear family This type of family consist of a man, his wife with dependant children. A nuclear family evolves with the birth of a child for a married couple. Out of a total of 191 households from the sample, 92 i.e., 48.16% are composed of nuclear families.

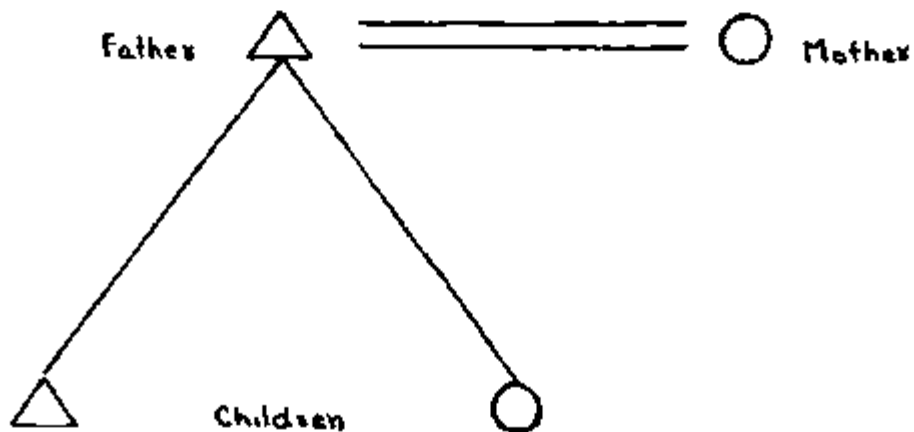

Fig 4.2 Structure of relationship in nuclear family

2 Incomplete family (two member family) :- This type of family consist of a man and his wife without children. Usually it comes into existence with the marriage of a man with a woman as they establish a separate household. There are as many as fifteen incomplete families in the total sample.

3 Broken family A broken family comes into existence with the death, divorce or separation of either the husband or wife in a nuclear family. Among the Mudugas, **out** of the total sample of 191 households, 5 (i.e., 2.61%) are composed of broken families.

4 Compound family This type of family comes **in** to existence also when widows or divorcees **with** children from a previous marriage remarry and beget children through the second union. The composition of a compound family **is** similar to that of a nuclear family consisting of a man, **his** wife and dependent children. But **it** differs from nuclear family **in** that **it** **is** formed through the amalgamation of nuclear family units or parts of them with children belonging to different parents. For instance, **Kakkilinkan** at Thaze-Abbannor had first married **Jakki** of Kurukathikallu hamlet, and **in** that union he begot three children. After the death of **Jakki**, **Kakkilinkan** married **Vellachi** who was a widow and already having a son **in** her first husband. **Kakkilinkan** **is** having a son **in** **Vellachi**. Now **his** household includes **his** first wife's and **his** wife's first husband's children apart from the child **in** the union between **Kakkilinkan** and **his** present wife (see fig 4.3). Out of the total sample, compound families are 3 **in** number constituting about 1.57%.

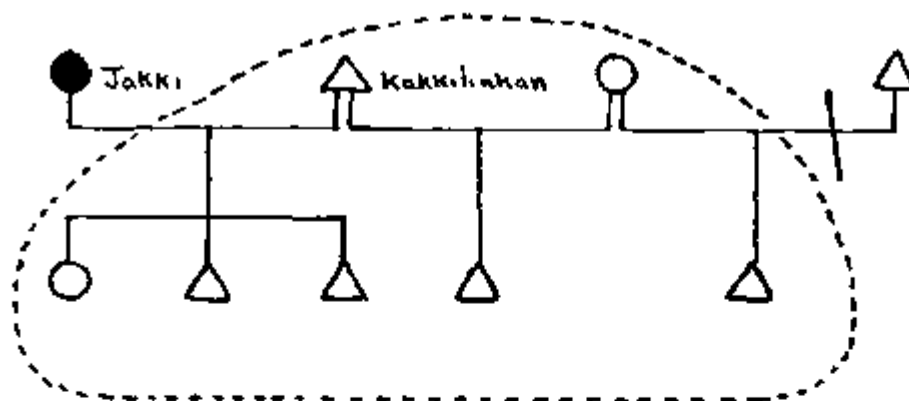

Fig 4.3 Composition of Kakkilinkan's family

5. Single member family : As the name indicates, this type consists of only one person, male or female, married, widowed or separated who must have been an husband / father, wife / mother or son / daughter in a nuclear family. There are only 3 cases of single member families in the total sample

Joint family . A family is characterized as a joint family when it includes more than one nuclear family unit joined lineally or laterally by common consanguineal bonds.

1 Lineal Joint family This type of family consist of the nuclear family units of two or more lineally related persons, their spouses and children. Lineal joint families are usually composed of a couple, their unmamed children along with married sons their spouse and children. Rangan's household in Anakkal Rangan's household represents a typical lineal joint household type (see fig 4.4) - Rangan's household consist of his wife, his son, son's wife, and children along with Rangan's unmarried daughter. Lineal joint families are also formed when parents alone join with the nuclear family unit of their son. In rare cases a couple with a daughter retained for uxonlocal residence with her husband and children also constitute a lineal joint family. There are only three such cases in the entire sample, one from Thaze-Abannoor and the other two cases from Mele-Kakkupadi hamlet. The total number of lineal joint households are nineteen and forms around 9.94 % of the sample.

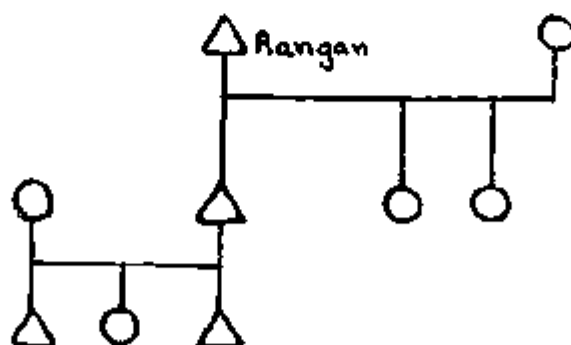

Fig 4.3 Genealogical composition of Rangan's family

2 **Collateral joint family** This type of joint family consists of nuclear family units of two or more brothers with their spouses and dependent children. There are no cases of collateral joint family in the total sample of 191 households among the Mudugas of Attappady.

3 **Lineal-collateral joint family** This type of joint family is composed of more than two nuclear family units joined both lineally and laterally. Typically this comprises of nuclear family of parents along with the nuclear families of two or more sons. Only one such lineal-collateral joint family is found among the Mudugas of Attappady i.e., Mallan's family at Veetiyoor.

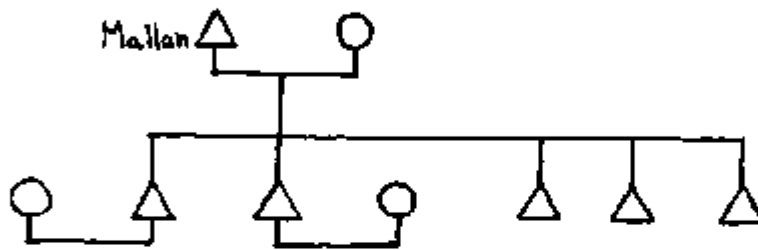

Fig 4.5 Genealogical composition of Mallan's family

4 **Bilateral joint family** This type of joint family consists of nuclear family units of opposite sex siblings. Typically this family comprises of a brother and a sister only along with their spouses and dependent children. Only one such bilateral joint family is found in Attappady.

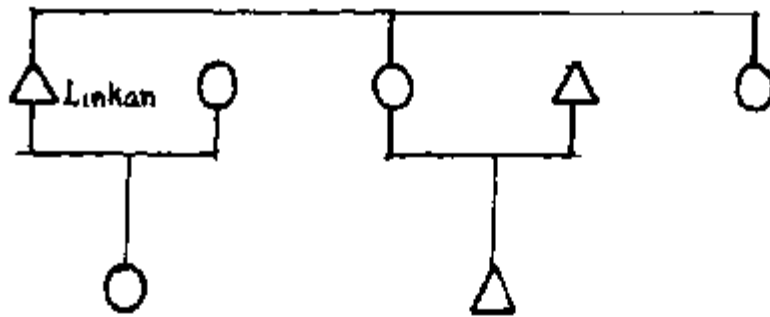

Fig 4 6 Genealogical composition of Linkan's bilateral joint family

5 Lineal-bilateral joint family This type of joint family is composed of more than two nuclear family units joined lineally and laterally through opposite sex sibling link. Typically this family comprises of parents along with the nuclear families of their son and daughter/ There are two cases of lineal-bilateral joint families in Attappady. Thus in one case at Thaze-Abbannoor, Panali's household consist of his wife and unmarried children along with his married son and daughter with their spouse and children making it a lineal-bilateral joint family.

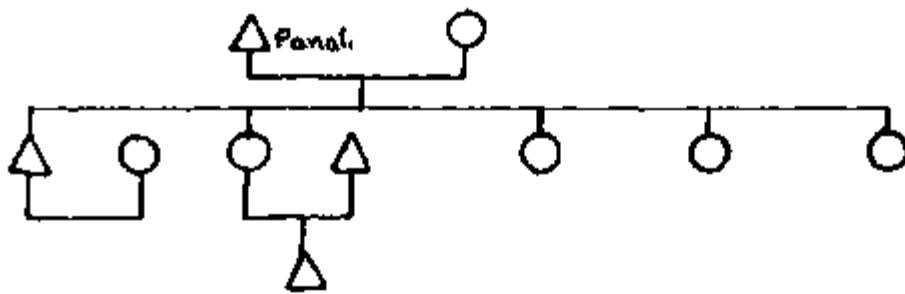

Fig 4 7 Genealogical composition of Panali's family

Dependent family This type of family is formed due to the addition of one or more dependent unmarried, widowed or separated kinsmen to any nuclear family or joint family types. Hence these type of families are different forms of nuclear or joint family types through the addition of lineal or collateral dependents.

1 Nuclear family with lineal dependents This type of family comes into existence when the parents in a lineal joint family becomes widowed or separated. This family consist of a man with his wife and children along with a widowed / separated parent and unmarried siblings. A nuclear family unit with an addition of widowed or separated parents also gives rise to the above family type. There are 20 cases of nuclear family with lineal dependents in the total sample.

2 Nuclear family with collateral dependents This type consist of a nuclear family unit of a man with an addition of unmarried or widowed brother with or without children. There are 4 cases of nuclear family with collateral dependent type in the total sample of 191 households.

3 Nuclear family with bilateral dependents This type of family comes into existence when an unmarried separated or widowed person with or without children is attached to the nuclear family unit of his / her opposite-sex sibling. Out of the total sample of 191 households, there are 7 cases of bilateral extended nuclear family. Thus at Mele-Abbannoor hamlet, Krishnan's household consist of his wife and children along with his widowed sister making it a bilaterally dependent family type.

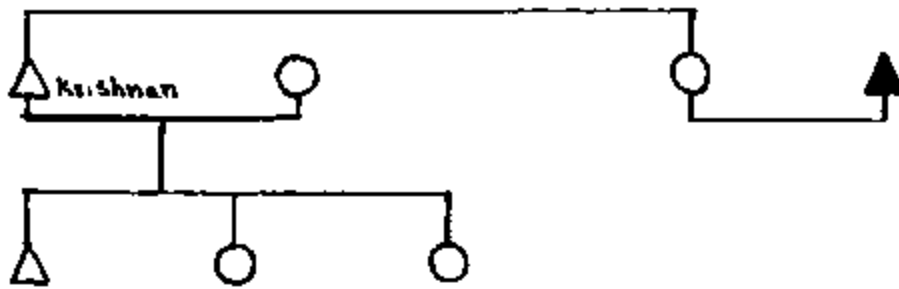

Fig 4 8 Genealogical composition of Krishnan's family

4 Nuclear family with lineal and collateral dependents This type of family consists of the nuclear family of a man with an addition of a widowed / separated parent along with a widowed / separated brother with or without children This type of family is represented by only one case in the entire sample At Thaze-Abbannoor hamlet, Kali's household consist of his wife and children, widowed father Ooshi, along with his widowed brother Velli and his children making it a nuclear family with lineal and collateral dependent type

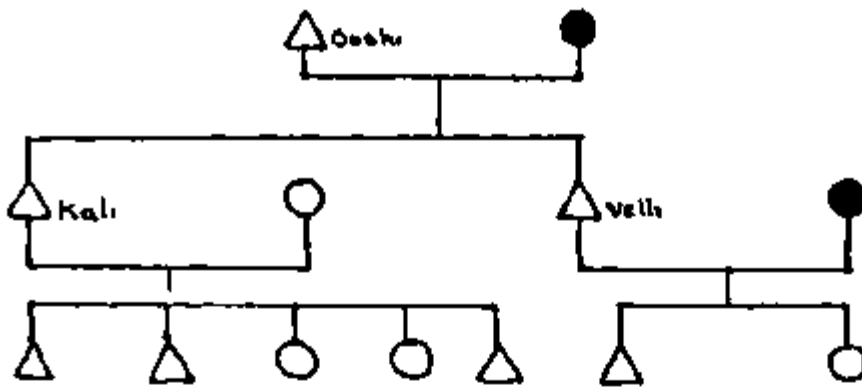

Fig 4 9 Genealogical composition of Kali's family

5 Nuclear family with lineal and bilateral dependents This type of family consists of the nuclear family of a man with an addition of a widowed / separated parent along with a widowed / separated sister with or without children This type of family is represented by only one case in the entire sample At Thaze-Abbannoor, Kullan's household consist of his wife and children, widowed mother along with his separated sister giving rise to a nuclear family with lineal and bilateral dependent type

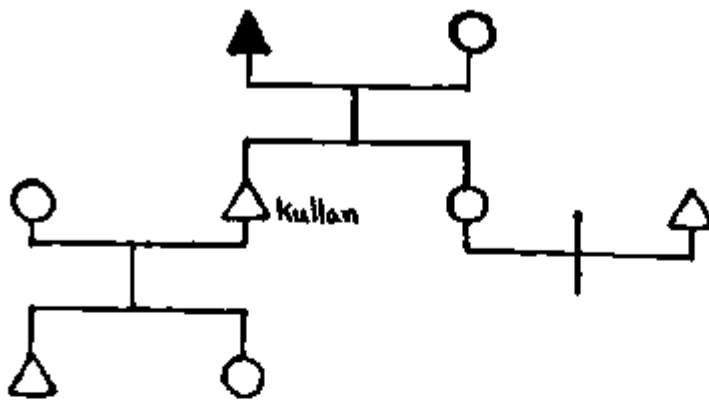

Fig 4 10 Genealogical composition of Kullan's family

7 Collateral joint family with lineal dependents This type of family consists of a collateral joint family with an addition of a widowed or separated parent. In the total sample, there is only one case of collateral joint family with lineal dependents. Thus at Pottikal hamlet, Gopi's household consists of his wife, his younger brother and wife, along with their widowed father making it a joint family of the above type.

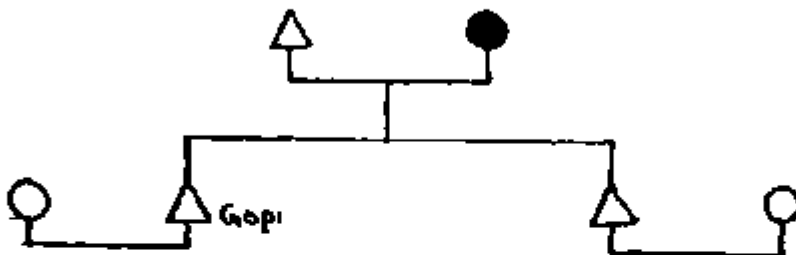

Fig 4 11 Genealogical composition of Gopi's family

6 Bilateral joint family with lineal dependents This type of family consist of a joint family composed of the nuclear families of a brother and a sister along with their widowed or separated parents and unmarried siblings This family type is represented by only one case in the total sample At Mele-Kakkupadi, Rangan's household consist of his wife, and his sister's nuclear family unit along with his widowed mother, widowed sister and unmarried brother

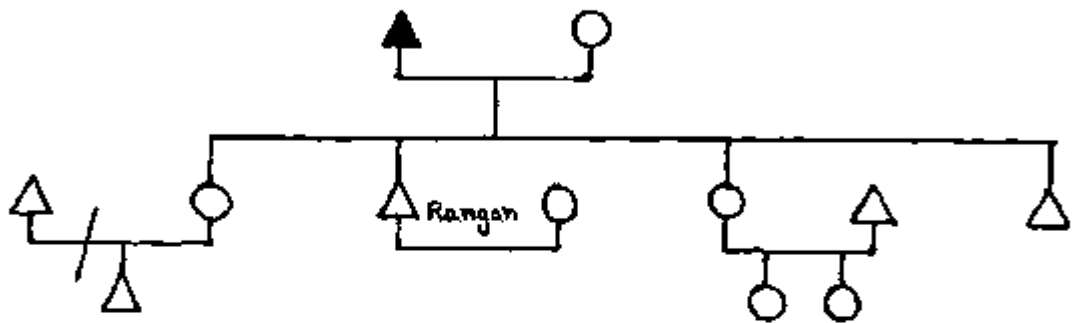

Fig 4 12 Genealogical composition of Rangan's family

7 Compound family with lineal dependents This type of family is formed when a widowed or separated parent is attached to a compound family There is only one case representing this type in the total sample

Broken families .

1 Broken family with bilateral dependents This type of family is composed of a broken nuclear family unit with an addition of an unmarried, separated or widowed opposite-sex sibling of either spouse with or without children. Usually this type comprises of a widowed man and his children along with his unmated or widowed sister. This type is represented only by one case in the sample.

2 Broken lineal joint family This type of family is composed of the nuclear unit of the parents (with unmarried children) and an addition of widowed / separated son / daughter with or without children. A broken lineal joint family is usually formed when in a lineal joint family, the married son or the daughter becomes widowed or separated. There are four such cases of broken lineal joint family in the sample. Thus at Mele-Abbannoor, Chekidan's household consists of his wife and unmated children along with his widowed daughter giving rise to a broken lineal joint family type.

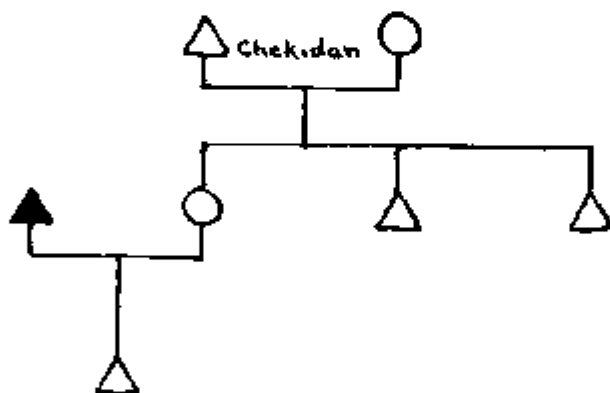

Fig 4 13 Genealogical composition of Chekidan's family

5 Broken family with lineal dependents This type of family is composed of a widowed or separated parent (with unmarried children) attached to the broken family unit of their married son or daughter. There are four cases of lineal extended broken families in the total sample. In one case at Thaze-Abbannoor, Mathan was staying along with his wife Chelli and children constituting a nuclear family. But the death of Mathan made the nuclear family to fall into the type of a broken nuclear family. Further later, Chelli's mother and Chelli's younger brother who were staying in a separate household shifted their stay along with Chelli's household giving it the form of a lineally dependent broken family type (see fig 4 14)

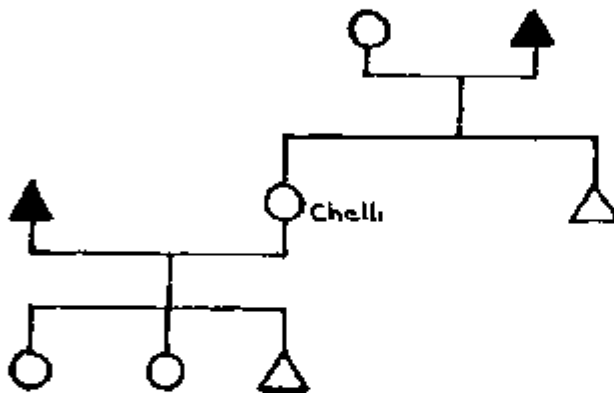

Fig 4 14 Genealogical composition of Chelli's family

In another case, Chathi of Mele-Abbannoor hamlet was married by Kakki of Thaze-Abbannoor. But later when Kakki divorced Chathi, she went back to Mele-Abbannoor and stayed along with her widowed mother giving rise to a broken family with lineal dependent type.

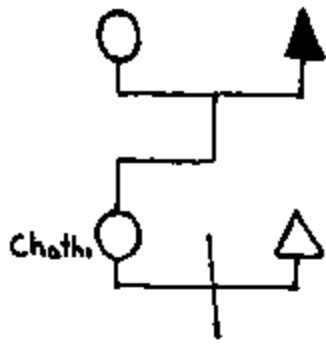

Fig 4 15 Genealogical composition of Chathi's family

6 Broken lineal joint family with bilateral dependents This type of family consist of a man and his wife along with the broken nuclear family unit of his son/daughter and an addition of a widowed opposite-sex sibling of either the husband or wife This type is represented by only one case in the entire sample Thus at Cholakkadu hamlet, Man's household consist of his wife, separated daughter and also his wife's widowed brother, making it a broken lineal joint family with bilateral dependent type

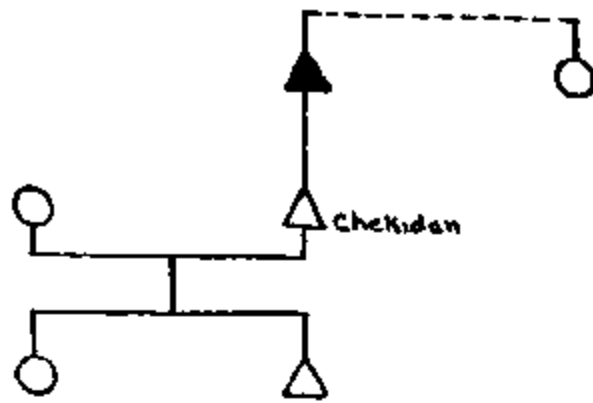

Fig 4 17 Genealogical composition of Chekidan moopan's family

2 **Incomplete family with secondary dependents** This type of family consist of an husband and a wife with an addition of unmarried, widowed or separated relative who are not members or spouses of the members of the constituent family There is only one case of supplementary incomplete family in the sample At Thaze-Abbannoor, the household of Chonke compnses of his second wife along with his wife's daughter's daughters giving rise to an incomplete family with secondary dependent type

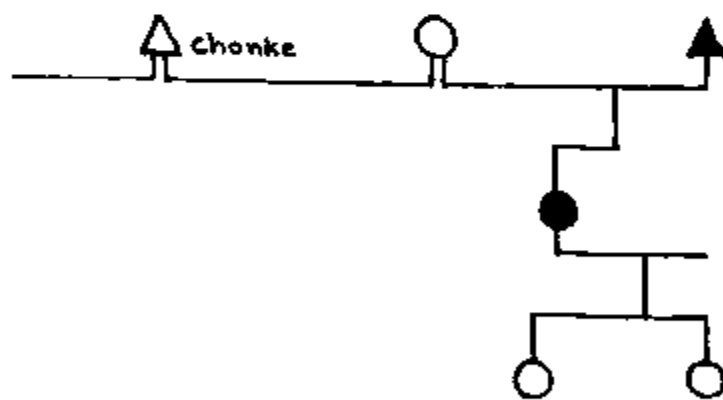

Fig 4 18 Genealogical composition of Chonke's family

Table 4,3 Genealogical composition of households

Sl No	Type of family	No. of households	Percentage
01.	Nuclear family	92	48.16
02	Incomplete family	15	7.85
03	Broken family	5	2.61
04	Compound family	3	1.57
05	Single member family	3	1.57
II.	JOINT FAMILY		
01	Lineal joint family a) Vinlocal	15	7.85
	b) Uxonlocal	4	2.09
02	Collateral joint family		
03	Lineal-collateral joint family	1	0.52
04	Bilateral joint family	1	0.52
05	Lineal-bilateral joint family	2	1.04
III.	DEPENDENT FAMILY		
01	Nuclear family with lineal dependents	20	10.47
02	Nuclear family with collateral dependents	4	2.09
04	Nuclear family bilateral dependents	6	3.14
05	Nuclear family with lineal and collateral dependents family	1	0.52
06	Nuclear family with lineal and bilateral dependents	1	0.52
07	Collateral joint family with lineal dependents	1	0.52
08	Bilateral joint family with lineal dependents	1	0.52
09	Compound family with lineal dependents	1	0.52
11	Broken family with lineal dependents	5	2.61
12	Broken family with bilateral dependents	1	0.52
13	Broken lineal joint family	4	2.09
14	Broken lineal joint family with bilateral dependents	1	0.52
IV.	FAMILY WITH SECONDARY DEPENDENTS		
01	Nuclear family with secondary dependents	3	1.57
02	Incomplete family with secondary dependents	1	0.52
Total		191	100

There is a considerable variation in the numerical size of the household depending on the type of family. A Muduga family size varies from a single member family to the maximum size of 17 members, the average size of a Muduga family being 5.01 persons. Although nuclear family is the single predominant family type, a large majority of families have 5 and more persons (see Table 4.4)

Table 4.4 Numerical composition of domestic groups

Total No of persons per household	1	2	3	4	5	6	7	8	9	10	11	-	17
Frequency (No of households)	3	17	30	33	34	35	13	11	8	4	1	-	1

Various social and other ecological factors permit related households to come together and function as a single domestic unit. But after a considerable period of time, they break and form independent units. The process of fusion and fission of households are observed in certain cases among the Mudugas which makes an household pass through various stages of growth and development.

Murugan's household at Thaze-Abbannoor is an example. Kakki's son Murugan after his marriage was staying in a separate hut nearby his father's and elder brother Bokken's hut. Murugan's household maintained close relation between Kakki's and Bokken's *koorai*. Later, due to a quarrel with his father, Murugan shifted his residence near to his wife's father Nanjan's hut. But after one year, Murugan's brother Bokken forced him to come back and reside nearby his hut. But in 1995 due to heavy rain and storm, Murugan's hut got damaged and he once again shifted his residence near his wife's father Nanjan's hut. This time Murugan stayed for some time in the hut of his WMM Regi (situated very near to Nanjan's hut), who had then shifted to her son Velli's hut. Later, Murugan's family shifted their stay to Nanjan's hut to stay along with Nanjan's family. At this time, Murugan's wife's brother Rangan and his wife was also staying nearby Nanjan's hut and all the three families formed one domestic unit, and cooking was done together in Nanjan's *koorai*.

During May 1996, Nanjan and his family shifted to his farm land and after two weeks his son Rangan also changed his residence to the field and erected his hut adjacent to his father's and both the family functioned as a single domestic unit.

Later Murugan's mother Chathi (who was staying at Mele-Abbannoor with her mother after being divorced by her husband *kakkı*), due to quarrel with her mother, came and stayed along with her son. After that, during 1996 August, Murugan his wife and children along with Chathi shifted their hut to Murugan's farm land and were staying together. But in the month of December, Chathi shifted her stay from Murugan's hut to her younger sister Ponnı's household at Mele-Abbannoor. This time, Murugan, his wife and children alone were staying in the hut. Still later, in the month of February 1997 when harvest was over, households of Nanjan, Murugan and Rangan shifted back to the hamlet and started staying together functioning as a single domestic unit.

In another case, Chelli, the widow of Mathan and her children along with her mother and younger brother were staying together in a single homestead adjacent to Chelli's brother Chellan's homestead. Though these two homesteads functioned as two independent domestic units, a lot of co-operation in labour and exchange of food were taking place between these two *koorat*. In the month of July 1996, Chellan's younger sister kade and her husband Sivalınkan who were staying along with Sivalınkan's parents, shifted their stay to Chellan's hut due to frequent quarrel between kade and her mother-in-law. Later in August 1996, all the members of these two households including Kade and her husband, shifted their residence to a single hut erected in the farm land cooking and eating together functioning as a single domestic unit. But later in the month of November, they abandoned this hut, and Chelli, Chellan and Sivahnkan erected their separate huts nearby in their farm land itself. Chelli's widowed mother and younger brother is also staying along with Chelh's household. Though they have separated into three households, these three units maintain very close interaction, economic co-operation and exchange of food with each other (see fig 4.19)

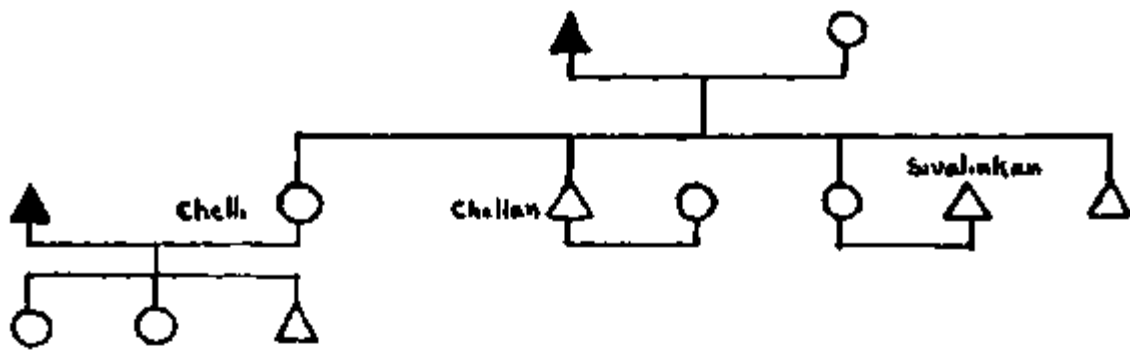

Fig 4 19 Joint household of Chelli, Chellan and Sivahnkan

The basic feature of nuclear family household among the Mudugas is the existence of a principal earning member in the household who supports other members, i e , his wife and children, and consequently holds authority over his dependents. In a nuclear family, the husband-wife relationship is the basic and the determining factor and along with it is present that of parent-child relationship giving rise to two sets of obligation and co-operation in the household. In a domestic unit consisting of a single nuclear family there is the co-operation of husband and wife in almost all domestic activities. They must form mutually depended members of the same domestic unit. Unless they are members of the same domestic unit and extend mutual co-operation and share their labour, they never fulfill the responsibilities of a husband and a wife.

Family is the fundamental social group of the Mudugas and have the supreme place of importance in the life of every individual. It is impossible for a man to lead a social life apart from the family of which he is a member. It affects his life at every point and manages his relations with the outside world. A person who does not belong to a family has no existence, because the society always identifies a man with his family.

Mudugas are patrilineal and patrilocal in nature. After marriage, the wife comes and lives with her husband. Even though a daughter after marriage ceases to be the member of her father's family, she maintains relationship with her parents and at times

visits her natal hamlet. Since descent in the family passes along the line of the male offspring, children are identified with the family line of their fathers and property especially farmland, is inherited patrilineally. Women virtually do not hold any right in the property of the family. However, when in need, women seek shelter in their natal land with their father and brother, and in certain cases they are also permitted to use a portion of their father's farm land. (This aspect of land use has been discussed in the previous chapter)

The family may be looked upon as a configuration of persons bound together by agnatic and affinal ties. Members enjoy different kinship status such as those of grand-father, grand-mother, father, mother, mother-in-law, father-in-law, daughter-in-law, son-in-law, son, daughter etc. Both male and female members perform multiple roles, assume various responsibilities and discharge duties and functions accordingly. The family discharges a large number of social, economic, cultural, biological and other functions for the well being of its members. Sense of solidarity, mutual co-operation and understanding, respect for age and value for kinship among the members signify the attributes of the family. Family ensures protection for the weak, particularly widows and provides support for the old.

All family or households have a recognized head, who represents the household in all dealings with formal affairs of the hamlet. When the household is constituted by a nuclear family, the senior male will be the head. Only when there are no adult male members in the household, is a woman regarded as the head of an household. However, it is to be emphasized here that, among the Mudugas, with respect to decisions in the domestic and familial domain, men and women are considered equal, and decision regarding production and consumption and other social matters are shared by the spouses.

Authority over the children lies with the father and his relations with children are characterized by respect and distance, whereas relations with the mother is characterized by warmth and closeness. The care of small children is the responsibility of the mother, and it is she who feeds and supports her children until they are old enough. Till 10-12 years of age both boys and girls interact and behave freely with parents. But after adolescence, a girl will be more attached to her mother and a boy with his father. Daughters grow up under the direction of their mothers. Mother and elder sisters train the

younger girls for the household tasks and give moral advice in worldly affairs. The father takes little interest in the affairs of his daughter. His chief concern with them is to ensure that they are well married. Boys come directly under their father's guidance. It is from his father, elder brothers and elder cousins, that a boy learns to hunt, make traps, fish, prepare fields, and engage in other activities of a man.

The patrilineal ideology to a great extent decides the bond between parents and children. The bond between the parents and sons remain longer than that of parents and daughters, because the parents in their old age expect care and support from the sons rather than from daughters who reside virilocally with their husbands in their conjugal household. For a man, since there is no change in the residence, there is a continuity in the process of shift from family of orientation to family of procreation. Thus, he will be having a circle of close relatives, either father, or brother or even sons. But in the case of a woman, she is entirely new to the situation and she has to build up her relation in order to become part of the already existing network of relationship in that particular hamlet. She attains this by allying herself most closely with her husband and extending or establishing relationship through him.

Mudugas often observe that father's sister (FZ) and brother's daughter (BD) in cross - cousin marriages tend to have more harmonious relationships. Thus they prefer to marry cross - cousins saying "*swantham irunthal barmaka, mamene mamine nalamai noduve*", meaning that if the girl is own niece, then the parents-in-law will be well taken care by the daughter-in-law. It is seen that in the case of cross — cousin marriages, mother-in-law and daughter-in-law get along well, and manage to share responsibilities without much conflict. Marriages with relatives living in the same hamlet leads to a great intimacy and interaction between the two households and these members are equally treated in both the households and get food and help from both the houses.

When the family becomes so large that the household can no longer provide room for everybody, usually a nuclear family unit splits off. Thus the eldest son will establish his own independent household nearby his father's household. However, such separated family keeps close contact with the parent family. The youngest son normally remains with his parents after his marriage. Since kinship ties persist even after co-residence is dissolved, the rights and duties that characterize the relationships between the members of

the nuclear family are not altered by the separation of families into independent units. These remain more or less the same whether the members comprise a single domestic group or whether they are separated into different domestic groups.

Usually a man establishes his own household during his father's life-time. He establishes his household nearby his father's in the same hamlet. Although he himself is a household head, he will still defer to his father, assist him with labor and support and consult him in important matters. So long as father and son reside in the same hamlet, they continue to participate in the same farmland, and the father continues to hold authority and control over his son. The authority exercised by the father on the son and the respect shown in return by the son towards the father is expressed through the formal relationship between a father and a son. Since land is very much abundant, and any one capable of doing work can clear his plot of land and do his separate cultivation, there is no demand for family members sticking on to one main property alone. Matured boys capable of doing work, even before marriage, while along with their father's family, clear separate land and do their independent cultivation. However, he is responsible to provide help and co-operate with his parents in their economic activities. Hence it is not at all difficult for a son in separating from the domestic unit of his father immediately after his marriage. He need not ask for any share in the property because there is no much individual ownership of such land property.

Even if they establish an independent domestic unit, at time of need, they can unite with the parent's group for a period as they like. But people or members living under same roof or one *koorai* will be having only one kitchen and cooking will be done together in one hearth. There are no cases of more than one cooking unit in one *koorai*. However, family members though dwelling in separate huts co-operate in most of their activities cooking and eating in the same hearth and thus functioning as a single domestic unit. Thus they say, "*emma bere koorel analum, adishi vanthu ontuthe*" (though we reside in separate huts, cooking and eating is done together).

When a woman becomes widow or get divorced by her husband in the initial phase of the marriage, she returns to her natal hamlet and live with her parents or brothers. Thus they return to their parental home along with children when their husbands die or when heavy quarrel takes place between husband and wife leading to divorce. The father or

brother offer shelter, economic and social security to their daughter / sister at the time of need. When a woman becomes widow, she finds her natal home more secure than her husband's land. But if she is having married or grown up children she will stay along with them in the husband's land itself. Though women seeks shelter in her brother's or father's hut, this will not continue permanently. When her children grow up and become mature enough to contribute for the subsistence of a domestic unit, she departs from her parent's or brother's unit and erect a new hut nearby and starts her independent household. However, her relationship and interaction with the parent's domestic unit continues and the mutual co-operation and sharing of food and labour continues. This stay of sister along with brother makes them more attached which leads to a situation where her son / daughter get married to his son / daughter and continue to reside in that land. But in most cases, when the male children grow up, they will return to their father's land along with their mother.

A nuclear unit consisting of a husband and a wife are capable enough to clear the fields and start their cultivation by their co-operation and sharing of labour. Moreover, two married women in a domestic unit leads to quarrel and disputes with regard to cooking, sharing of food, and other household management. But old women especially widows or mothers will not be a problem, because they never play an active role in the domestic activity of the household but remain as an attached member to the domestic unit. A woman with her husband in their old age prefer to stay along with their son. But if she is alone or widowed, prefer to stay along with their daughters rather than their son and daughter-in-law. This shows that if two women come together in one domestic unit, it leads to minor quarrels and conflicts. But between a mother and daughter there will be no such issues. They will be free and even if issues crop up, will not be taken seriously since it is between mother and daughter. A daughter's relationship towards her mother will be more close and intimate. She is more affectionate towards her mother and when quarrel occurs, it is the daughter who is expected to bear the scolding and rarely she retort. Similarly, a woman should be respectful to her mother-in-law and should maintain good relationship with her. However, in certain cases, there lacks an intimate relationship between mother-in-law and daughter-in-law which results in tension, quarrels and also accusing the other when they come together in one household. Even when the nuclear

families of two brothers live together as one household, there do occur quarrels, and their wives are prone to involve in squabbles for various reasons. Women like to be completely independent in their domestic activities especially in cooking and serving. In spite of being closely related, they remain as two independent domestic units but continue their sharing and co-operation of food, labour and maintain a **high** degree of interaction.

Brothers who are closely related **will** erect their huts nearby and reside **in** one area. Parents, **if** they are capable of doing **work** and looking their farm land, **will** reside **in** a separate hut forming an independent **unit** but maintain close interaction **with** their son living nearby. If they are very old, widow / widower, they **will** be attached to the household of any of their sons, usually the youngest son. However, they **will** be cared by other children also and food **will** be given to their parents from the households of all the children. Thus the care of old or widowed parents **will** be shared equally by all the sons.

A person during **his** life time belongs to two or three domestic groups. The first would be his nuclear family of orientation, the second would be **his** family of procreation with spouse and children, and the third would be **in** old age **with** one's son and son's wife and children. Out of the total of 35 old couples **in** the sample, 17 couples **in** their old age are staying along **with** their son's household and 10 are dependent to their sons who are unmarried. Only 5 couples are attached to their daughter's domestic **unit** and 3 couples are staying alone forming their independent domestic **unit**. It is very clearly evident from the analysis that parents during their old age prefer to stay along **with** their son's family. In rare occasions they do get attached to the daughters household especially **in** cases where they have no sons. **This** goes **in** conformity **with** the **patrilineal** principle of the Muduga kinship system.

Table 4.5 Attachment of old couples to household of **kin**

Relation with members of the attached household

Married son	Unmarried son	Daughter	Alone
17	10	5	3

After the marriage of a son, the newly married couple will not stay for a long period along with parents forming a joint family. The new couple is capable of cultivating their own separate farm and in the process separates themselves from the family of orientation and start their independent domestic unit. Eventhough they separate from their parent's domestic unit, they are closely attached to their parents' household and mutual co-operation and sharing of labour takes place.

At Thaze-Abbannoor, the domestic activities of **Kakki's** household is done mainly by his wife **Neeli**, daughter **Pavashi** and the recently married daughter-in-law **Mathi**. After getting married to their son **Raju**, Mathi has become a member of that domestic unit and is doing most of the work for Kakki's *koorai*. However, Mathi maintains her close relation and interaction with her mother's and elder sister **Vellachi's** *koorai* which is situated very near to her husband's *koorai*, and assist them also in their household affairs. Moreover, Mathi is getting regular share of food from her mother's *koorai*. During the crop season, Raju and his wife erected their small hut in the farm land, and were living separately from their parents leading an independent unit in the farm for about 3-4 months. Even then, during day time they use to visit the hamlet and borrow provisions from his parent's hut. Thus, though they have started their domestic unit in the farm hut, it was not totally an independent unit.

After the complete separation of domestic units of sons from their parental joint family household, each man is the head of his own independent nuclear household and manages it's affairs. All the ceremonial gifts and obligations are transacted and discharged in his name. However, regarding the payment of **bride-price**, it is the father who takes the responsibility of making this payment and decision on matters related to marriage. He will be assisted in this aspect by his elder sons. Thus it is the father who represents the related families and make the payment on behalf of the entire kin group.

Households of the brothers constituting the minimal unit of the descent group and other closely related agnates help one another and co-operate in all occasions, and exchange food and labour much more than the members of the kin unit of a wider span. In day to day interaction, economic activities and other affairs, these close relatives usually residing nearby forms small km units or close circle of relatives and function as corporate

units It is to be mentioned here that, apart from own siblings and sons, these kin units also consist of close affines usually brother-in-laws, who are residing **near by** ⁷

Division of labour

Households are the basic domain in which division of labour and sharing of its product take place Different members in a household perform various roles, duties and obligations to perform for the benefit of the family and household as a whole Members contribute their labour power according to their capability and also in accordance with the degree of responsibility and the products are consumed or utilised by the entire members together

Even though members of the household work together for the collective benefit, their relative contributions vary from person to person based mainly on sex and age as well as their skill and training Thus in a domestic unit, fully **abled** persons who are active economically have greater standing than the disabled and less productive aged ones The welfare of the former sort of household members are treated as a matter of concern than the welfare of the latter, and in certain cases, the former are apt to find their needs more often met However, to a large extent such discrimination as to the welfare of the members are suppressed and the product of the labour are distributed and shared among the household members irrespective of age and sex

The necessity for co-operation in subsistence activities is essentially a function of the sexual division of labour and hence the ideal pattern is that at least one member each from both sex should be the minimum composition of a domestic unit Males and females must depend on each other, for each sex is trained in certain skills which the other sex is not However it should be mentioned here that under certain circumstances, a man or a woman will often do some unskilled task normally done by the opposite sex Thus, when women undergo pollution during menstruation period, it is the husband in the absence of other adult females, who take care of the preparation of food Female children if present will help and assist him in this task Similarly, women on certain cases use to do hazardous work like breaking **fire-logs** in the absence of males Thus the conventions of the sexual division of labour especially for tasks not requiring special skills are in mos'

cases not rigidly maintained. And major task requiring skilled labour in most cases are taken up only by the particular sex ,

In shifting cultivation all the members of the household co-operate with each other in almost all its phases from clearing the bushes till the harvest. Certain activities in the cultivation process however are sex linked and needs special skill. The male members of the household are responsible for cleaning the early set of fields and the female members are responsible for most of the subsequent care of the fields, though men and children may help

It is the major task of the men to set the field ready for cultivation. This cleaning of fields (*kadu saveral*) involve the cutting of bushes and shrubs and burning them when it gets dried. The major part of the shifting cultivation (*kadu pani*) such as ploughing and sowing, weeding and harvesting, will be done mainly by the women. Weeding is also an assignment in the phase of shifting cultivation performed strictly by the females. Normally all the female members of the related households collect together to do this weeding work. But in certain cases, the tall bushes which grow among the *tuvari* crop will be slashed down by males. Among Mudugas, women is more associated with the field (*kadu*) and it is mainly her responsibility to manage the different affairs involved in the cultivation. This close association of women and field is clearly depicted when people often say “*rantu pennamba kettiyal rantu kaadu bettadom*”, meaning “if you marry two women, you should also clear two fields”. Moreover, from this saying it is clearly evident that no two women even if married to one man like to live together and co-operate as members of same domestic unit. They nevertheless clear and cultivate separate fields and establish their independent domestic unit by living separately. However, this custom of a man maintaining two wives at the same time is very rare among the Mudugas and there is only one case of this sort which is of Vellinkiri's family

When the crops become matured and is ready to produce the yield, men engage in watching the farm land. They erect small watch-huts (*kava sala*), and spend their nights in the fields, watching the crops from birds and wild animals. In some cases, both husband and wife shift their residence to the field so as to spend more time in taking care of the crops and will return after the harvest is over. However, in both cases it is the male who is mainly involved in the duty of watching the fields. Men will also engage other than this in

hunting and trapping of wild games, collecting honey, cycas seeds, fire woods, felling bamboos etc , which is hazardous and needs more labour and skill

Women and children are mainly engaged in gathering and collecting of green leaves, roots and tubers, mushrooms etc Men rarely engage in this activity of gathering Collection of honey is done only by men They are very much skilled in this activities such as climbing big trees, driving away the bees etc , and also tracing the way and finding out the honey comb in thick forest Hunting is strictly a male activity where group of men gather together and proceed into the forest in search of wild game for two-three days In certain cases, husband and wife together go into the forest in search of roots especially *pada veru* which is used for trade in market This is during rainy season when no other main agricultural work is possible Sometimes children along with elder females also go in search for roots and tubers both for sale and consumption Fishing is also done by females in the nearby stream and fields and during rainy season women and children together engage in collecting crabs (*nendu*) and small fishes from near by streams and fields

Male members also engage in making agricultural and other household tools made of wood such as mortar and pestle, wooden spoons, bamboo benches for sitting, brooms, handles for iron implements etc It is the duty of the male members to trade their products like grams, milk, or honey in the market and with the money to buy household provisions necessary for running the domestic unit They are supposed to earn money through this trade or through labour work and ensure that the household is sufficient with the necessary-items Though women at time go for labour work, it is not regular and they never involve in the financial matters which is restricted to the male members who is the head of the household

Table 4 6 Sexual Division of Labour

Male tasks	Female tasks
Clearing fields slashing, cutting and burning	Cultivation : sowing, weeding and harvesting

Watching of fields		Collecting roots, tubers and green leaves
Hunting, trapping and fishing		Collecting crabs and small fish from fields
Cutting bamboos, collecting cycas seeds and gathering honey		Pounding & grinding grains
Labour work, selling and trading forest products		Cooking and serving of food
Building huts		Plastering floor and minor repairs
Skinning and butchering of games		Fetching water and washing
Making wooden utensils and handles for implements		Caring children
Herding and milching cattles		Herding goats and keeping chicken

Men at times work on daily wages for outsiders and manage the household expenditure. Apart from shifting cultivation, gathering green leaves, roots and tubers, fire woods, etc it is the major responsibility of the women to manage the domestic activity of like of cooking and serving of food for the members. Females will have the sole control in household affairs and other related domestic activities. Grains like *rai*, *same*, *tuvari* and other domestic provisions will be in the control of the women and it is their duty to keep the grains stored so as to use during the rainy season when nothing could be earned or no labour work is available. When they are in need of money or there is a scarcity of other household provisions, men will take away some of the grains stored in the *koori ai* without the knowledge of women and sell in the market to buy rice and other provisions. Thus the routine work of the household is mainly in the hands of women and a man largely engage with work in the forest and other associated tasks. Men actively engage in the building of huts, when women do most of the maintenance and minor repairs. Though women and female children go for collecting fire-woods from nearby fields, it is mainly the men who proceed into the deep forest and cut big logs to use as fire-wood. Unlike men, women very seldom go as wage laborers to work for outsiders, but are mostly confined to ones own domestic activities and farm work.

Mudugas equate women with land and often say that a man's life will be smooth or comfortable only when he is assisted by a female through which he owns a farmland and cultivate it Thus women (*pennu*) and (*kadu*) makes a man establish his own household (*koorai*) This shows that only through the mutual co-operation of male and female, that they can cultivate the field and establish their household They also consider that a person without women and land is not a complete Muduga man, and they say, "*pennumkadum illathavanuemmuthil bele ille*" (One who is without women and field do not have any value among us) Thus the assistance of women ensures a man's food This is clear when Mudugas often say "*pennu irunthal ninakkupittu kedakkum*" meaning If you have a women you will get food

A husband and a wife should be very much sincere and particular regarding their household responsibilities and obligations, and should give utmost importance to it than any other This aspect of household responsibility, especially that of a women is very well depicted in a Muduga proverb "*konte minukki alane kollum, mettam kadu uluthavaneyum kollum*", that a woman who always care for her beauty will destroy her husband like how a hard and rough land destroys the plougher This says that a woman should not be always bothered about her beauty only, but should be dedicated to her husband and must be sensible about the responsibilities of her household If wife and husband do not co-operate with each other and the wife fails to discharge her obligations then there is a serious threat to the stability of such marital bond

Children from young age itself start assisting their parents in most activities When children reaches the age of 8 - 10, they are matured enough to contribute their service in household duties and other activities like fetching water, collecting roots, tubers and fire-woods, pounding grams, herding cattles and assisting their parents in agricultural activities As they enter adolescence, they begin to play a major role in subsistence activities, helping in all hard work of their sex Grown up female children assist their mother in cooking and take charge of the domestic or household activities in her absence A woman will be assisted by her daughter in carrying out agricultural activities and other domestic works A girl goes out with her mother to the field to assist her from an early age She is made to carry small farm implements like sickle, hoe etc., or to assist her mother in various agricultural activities like sowing, weeding or even harvesting Later

she becomes a regular helper in work in her parents farm land and in the corporate working group of kinsmen and others in which her mother joins Female children also take responsibility of looking after young children in the hamlet when their mother is away from the hut Male children will engage more in the farm land activities with his father or will clear their own field and do cultivation and start contributing to the subsistence of the household /

Thus apart from the co-operation between husband and wife, another important role of domestic organization is that a parent and child are mutually obliged to help each other when either needs help If the child is too young or the parent too old, he or she must be supported as a dependent by the other

Depending on the members constituting the domestic unit and the nature of the responsibility carried out by them for the functioning of the domestic unit, members of the household fall into two categories These are fully abled persons and are active economically contributing a major share of labour to the domestic activities The other type of members are marginal members or attached members who have joined previously existing and viable units and whose labour is not essential or necessary to the viability of the unit Though in certain cases, old parents are members of the domestic unit since its formation, their labour is considered marginal to the overall functioning of the domestic group and hence they are treated as partially abled members Children who are between the age of 8 - 14 are also treated as partially abled members since they only assist their parents in domestic activities

Table 7 shows the distribution of abled persons in the representative sample of 191 households Here persons above the age of 14 and below 55 and who are fully capable of contributing labour for the functioning of the domestic unit are considered as abled persons Out of the 191 households, 120 households are having one abled male person and 113 households are having one abled female person. Households with two abled male persons are 44 in number and 42 households are with two abled female members. When households with 3 abled females are 28 in number, only 16 households are having 3 abled male members There are 3 households with 4 abled males and households with 4 abled females are 4 in number. There are two households with 5 abled male members. In the entire sample there are 6 households without one abled male member and 4 households

without one abled female member Out of a total of 959 persons, there are 297 abled females Compared to females the number of abled males are slightly lesser, and are 278 in number

Including both males and females, 85 households are having 2 abled members and 43 with 3 abled members There are 28 households with 4 abled members The maximum number of abled members (both male and female) that an household consist is 7 and there are 6 such households in the sample One abled member households are 6 in number

Table 4 7 Distribution of abled members per household

	No of persons per household								Total Persons	Average no per household
	0	1	2	3	4	5	6	7		
Males	6	120	44	16	3	2	-	-	278	4.5
Females	4	113	42	28	4	-	-	-	297	1.55
Males & Females	-	6	85	43	28	17	6	6	575	3.01
Partially abled									384	2.01
Total									959	5.02

A feeling of alienation and disappointment and a notion that one is helpless is not at all seen among the older generation The) do discharge economic activities according to their might such as assisting in cultivation, herding cattles, collecting tubers and green leaves, looking after children etc , and make themselves busy always This state of mind of the elders is mainly based on the attachment, love and affection shown to them by the younger generation The younger generation accepts and acknowledge the presence of elders in the family and give due value to their advice and suggestions

Households and economic co-operation

Much of the corporate economic activities can be seen to be more clear in the functional level of the household and hence a family or household thus obtains expression in economic spheres as a self-sufficient entity. In most cases, the one and the same. However, when in need, closely related families and kinsmen often work as one unit on the agricultural land. Apart from the individual household or the family, bonds of kinship underlying wider kin groups tend to organise economic activities among the Mudugas. This type of mutual dependence on kinship relations for economic activities and co-operation is an important feature among the Mudugas. Despite the fact that many are living in independent households, they receive the needed recognition and support from extra-familial kin. Thus in most cases, the kin group and the work group tend to be one and the same. Between these closely related households sharing of cooked food also takes place.

There are different levels or circles of kin falling between immediate relatives of the close circle and distant relatives of the wider circle from whom one can derive help and co-operation in economic and other domestic activities. Between the members of different nuclear households in an hamlet, the obligations are more intense and the social interaction more frequent, similarly as existing among the members of a joint household. So that, though they reside as independent nuclear households, their mutual rights and obligations and day to day interaction, in fact, makes them to function almost like a joint household.

Thus there is no greater logic to the argument that large extended household types are essential to better fit an economy which claim large number of working members.⁹ Hence it is important to see how individual households are better organized to meet their economic needs and how they arrive at these interpersonal relation and interaction for such relatively large group activity.

These co-operation and corporate nature extends further to other levels of kin or kin circle based on the degree of closeness at the time of necessity of labour power. Thus, Kapadia rightly points out, "even in those cases where the property is divided and the income is not pooled the constituent families maintain their connection through mutual co-operation and rights and obligations other than those of property" (1959 : 261).

It is very important to understand that for a household to function as the primary unit of economic co-operation, it should include a minimum of one conjugal unit. Without this basic sharing of labour and co-operation i.e., between a husband and a wife, it cannot form a complete household. Thus it is evident that among the Mudugas, nuclear family is the form which tends to be viable for a longer period and hence the typical household type. Families remain small because they are efficient enough to carry out their domestic functions, and moreover, when it finds difficult for managing the agricultural process alone, they can seek help from the related households which is a type of mutual co-operation and the help will be paid back when the others are in similar need.

There are various levels or units of economic co-operation constituted by very close as well as wider kin circle constituting of distant relatives. The primary or basic unit of co-operation and sharing is the nuclear family consisting of husband and wife who reside together, cook and eat together and manage one farm land. Next to this level of co-operation is the unit consisting of primary kinsmen other than once nuclear family, but form members of the same domestic unit (this is with regard to a joint family household), cooking and eating together and co-operating in domestic and agricultural activities, but manages their independent fields.

The next sphere of kinsmen who engage in co-operation and sharing of labour is composed of different but closely related households of immediate or primary kinsmen with whom there is frequent interaction and sharing of food. This food sharing unit is known as the *beethakarai* (will be discussed later in this chapter). Outer to this circle is the wider kin group consisting of relatives of the secondary kin type who may belong to the same descent group or may be close affines but with whom there is no frequent interaction in domestic activities but only co-operate and participate in agricultural activities at the time of labour need. The last and the outer most sphere consists of any other member living in the hamlet with whom there is no close relationship and obligations, but whose help and co-operation can be asked for at any time which should be strictly reciprocated. In the first two levels of mutual help and co-operation, i.e., among the immediate close kin, there is no strict rule of reciprocity and even if the help is not returned, no one takes notice of it. This is like what Evans Pritchard says of the, Nuer, 'it is all giving and begging' (1951 . 132)

Analyzing these different levels of co-operation, it is seen that the areas of co-operation varies from one level to the other, i. e., activities which are performed together and separately by the component families. This variation in co-operative nature from the basic unit to the wider unit is shown in the following table

Table 4 8 Units of co-operation and their activities

Unit of Co-operation	Activities performed together	Activities performed separately
Nuclear family	Cooking, eating, dwelling, farming	--
Joint household with more than one nuclear family	Cooking, eating, dwelling, & frequent sharing of labour	Farming
Beethekarar labour	Sharing of food and sharing of dwelling, farming	Cooking, eating
Wider kin unit dwelling, farming	Co-operate in economic activities	Cooking, eating,

This nature of co-operation can be explained with the case of Mele-Abbannoor Kaden's household and the different levels of corporate units engaging for his economic activities. Kaden's domestic unit is composed of his nuclear family consisting of his wife and unmarried son along with another son Kali and his wife, thus making it a lineally joint household. Both Kaden's unit and his son Kali's unit co-operate and participate together in almost all economic and domestic activities. They reside together in one hut, cooking and eating together forming one commensal unit. Though they function as one unit in other domestic activities, with regard to cultivation, they form independent units maintaining their separate fields, such that only sharing of labour and co-operation takes place. However, this labour exchange is very frequent. The income from the crops cultivated by both units will be pooled together so as to manage the domestic affairs jointly. But whenever there is more work which cannot be performed by members of the joint household of Kaden, he seeks help from his immediate kin, viz., his younger brother Panah and his elder son Linkan who are staying near by and whose households having close interaction and sharing of labour and food between Kaden's unit.

The next circle of labour unit includes kinsmen of the second order consisting of Kaden's sister's husband Nanjan's and daughter's husband Chekidan's household with whom there is no frequent interaction but only co-operate and participate when in need of labour. Outer to this sphere of kinsmen are members who are not immediate or close but are distant relatives residing in the same hamlet (i.e., distant agnates and affines) who work on wage basis and with whom there exist a strict rule of reciprocity (see fig 4 20)

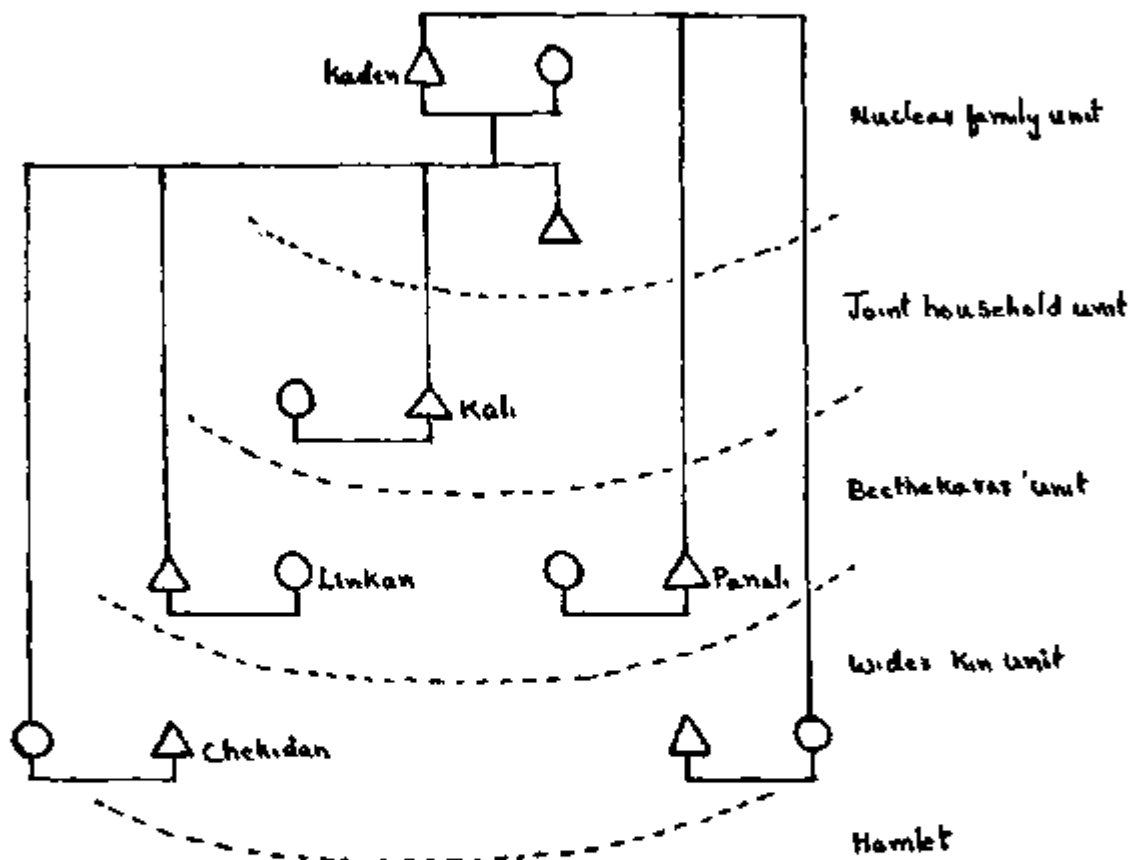

Fig 4 20 Different levels of corporate units of Kaden

In spite of the structural difference that is always maintained between the agnates and affines in their kinship behaviour ceremonial roles and obligations, they nonetheless form a single unit and co-operate together in many other day to day events and occasions. Agnates and affines exchange services and extend mutual help in their daily living. They together participate in almost all economic activities such as cultivation, hunting, fishing,

gathering, construction of huts, etc. Here, an analysis of the composition of **Muduga** hunting groups show co-operative nature of agnates and affines residing **in** the same hamlet

Table 4 9 shows the **kin** composition of 45 hunting groups observed at Thaze-Abbannoor at different **time** between 1996 March to 1997 March. The Table shows that out of the 45 hunting groups observed, only 10 groups were composed of agnates **alone**. When groups consisted of brothers alone were 6, that which consisted of two **brother-in-laws** were 11. The Table also shows that there are also hunting groups at times composed of husband and **wife**, and there are two cases of such group. **This** shows that the sharing of labour and co-operation **in** economic activities are not restricted to the members of the households or the close **agnatic unit**, but also includes closely related affines residing **in** the hamlet thereby reducing the occurrence of economic units based strictly on descent

Table 4 9 Composition of hunting groups indicating the nature of relationship

Categorical composition of hunting group	Frequency
Brothers	6
Ego , Affine- G^0 (2 members)	11
Brothers , affines - G^0	12
Brothers , agnates - G^1 , agnates- G^2 , affines - G^0	2
Brothers , non-agnates (affine's affine) - G^1 , affines- G^0	1
Brothers , affines- G^1 , affines- G^{-1}	1
Brothers , agnates- G^1 , affines - G^0	1
Brothers , agnate- G^1	1
Ego , agnates - G^{-1} , affines- G^{-2}	2
Ego , affines G^{-1} , agnates- G^1	1
Ego , agnates - G^{-1}	3
Ego , wife	2
Brothers , affines - G^{-1} , affines G^1	2

G — refers to generation, and G^0 means same generation, G^1 first descending generation etc

Pattern of Residence and sharing of Food

Huts and residence Muduga huts are relatively small constructed using simple materials like bamboo from the forest and strong climbers or sliced barks for tying the poles. Dry *dharbha* grass (a wild variety of grass) is used for thatching the roof The hut is usually rectangular with triangular shaped roofing pattern. Usually two or more huts are built

attached to one another in a linear row A Muduga hut typically consists of one main room which is also the kitchen called *loorai*, and a small lengthy verandha called *dheetti*. The main room is sized around 2 ½ meters width and 3 meters length and is used for cooking, dining and sleeping. The *dheetti* is one meter wide and of 3 meters length. Usually for the Muduga huts, the roof is too low to permit standing upright inside the hut. Floors are neatly plastered with mixture of cowdung and clay and is polished with polishing stones (*minukku kallu*).

The hearth (*kudia*) is situated in a corner represented by three stones and will be attached to the wall by a small platform (*mathilu*) where essential provisions like salt, chilly, sugar, tea powder, etc., are kept. There is no specially constructed ventilation for the hut and it will be always dark inside. A Muduga hut is usually small in size, and there will not be much space for easy movement of people. However, few members can comfortably remain inside a hut and engage in household work.

In a Muduga hut, the kitchen which is the main room is itself the sleeping room. They have nothing other than the mat to spread on the floor on which they sleep stretching their legs towards the hearth. During winter season, the hearth will be burning throughout the night. Those members who sleep outside the kitchen in the *dheetti* keep large logs burning in the centre and sleep around the fire. During winter season, nights are chilly and they keep large slow burning logs and put fire in the front-yard of the huts and members of neighbouring huts gather round the fire warming themselves. This type of camp-fire is called *theebendi*. During nights there will be usually 3 or 4 such *theebendi* sites at different corners of the hamlet.

Above the hearth will be seen the loft made of bamboo which is used for storing domestic equipments, grains and other provisions. This loft which is made of bamboo is called *grashi*. On the opposite of the hearth there will be strong bamboo platform erected on four bamboo legs, which is called *pattada* for keeping big bamboo baskets permanently installed for storing grains, earthen pots and other household utensils. In another portion of the hut attached to the wall will be having a small elevated region to keep vessels for storing water.

The grinding stone (*beesu kallu*) another important item usually kept in a corner of the *dheetti* which is used for powdering *rai* and *tuvan* grains. Every hut may not have

this grinding stone, and souse the neighbours stone Similarly, wooden mortar and pestle (*wal* and *ulakka*) which **is extensively shared** by neighbours There may be usually **only** 3 or 4 wooden mortars for one entire **hamlet** consisting around 25 to 30 households and they **will** be always kept outside the hut **in** convenient corners so that any one can use **it** to pound grains when necessary These mortars are not owned by any particular household but **it is** commonly owned by the hamlet However, wooden pestle **will** be owned by few households which **will** be shared by others who do not have

Very closely related kinsmen may erect huts joined **in** a linear row **with** only the kitchen separated and having a long single joined varandha called *otndhetn* However, the main room and the *dheetti* **will** be having separate doors (*basa*) which are very small so as one should bend much to go **inside** The lack of ventilation and presence of small doors are to protect from heavy cold and storm A single hut **will** never be partitioned **into** different rooms so as to accommodate other households

The members of the family / household tend to reside or inhabit together **in** one hut They cook food, eat and sleep under one shelter **in** most cases But **in** certain cases where the family consists of grown up male or female children or other members, they tend to sleep in other neighboring huts **if** there **is** no sufficient space Thus, the grown up children of the hamlet **will** sleep separately **in** any hut which **is** spacious **This is** the *bandaru urangra koorat* (boys sleeping hut) or *veeniar urangra koorat* (girls sleeping hut) Usually there **will** be no separate hut specially made for **this** But boys and girls and sleep **in** any hut where members are few and have sufficient space to accommodate quite a few members These are usually huts occupied by aged couples or a widowed person, or whose members have shifted to their farmland hut Thus grown up male and female children (*bandaru* and *veemar*) sleep along **with** their age mates **in** other huts, and married people are restricted to their own huts **with** their wives and younger children When people come from other hamlets as guests, they **will** be allowed to sleep **in** the *dheetti* or **in** any other hut where there **is** sufficient space It **is** clearly evident that, while old and married people normally sleep in their own *koorat*, a good number of younger and unmarried persons **will** be sleeping elsewhere The sleeping arrangements of younger persons are usually quite temporary, changing not only with the **availability** of places to sleep but also **with** the availability of friends of the same age and sex. After they reach

adolescence, and until marriage, young persons often prefer to sleep with their age-mates rather than with older or younger members of their own families. This is the place and time for entertainment, fun and merry making, story-telling, sharing their day's experiences and all sorts of activities attractive to adolescents and young adults.

Though few members of the household reside or sleep in other neighbouring huts during night, this will not affect their household membership, nevertheless they remain as full members of the domestic unit where he / she participates in domestic affairs and share his / her labour. Thus, it should be mentioned here that though members, especially children gather together and sleep in other *koorai*, they never become part of that domestic unit merely because of sleeping, but belongs to different households. They will finish their meals from their respective *koorai* and in the night gather together for sleeping where there is sufficient space.

Children who go to sleep in other neighbouring huts will sleep together in the *dheetti* which will also be closed on four sides. They will not sleep in the kitchen or the main room which is restricted for the *koorakarar* (household members). But if there are huts where no members are staying or cooking, then children who come for sleeping can use the main room also. Among the Mudugas, the kitchen is considered as the main room and the members of the household sleep in the kitchen which is also termed as *koorai*. Kitchen or the main *koorai* is restricted only for the members of that household to dine and sleep and is mostly considered as a private place for the family members.

Neighbours in the hamlet who come for casual visit will not often enter the kitchen or *koorai* but will restrict themselves in the *dheetti* itself. However, when relatives from other hamlets visit a hut as guests, they will be allowed to dine with other household members in the kitchen, but will sleep either in the *dheetti* or other hut where they could be accommodated. Mudugas never serve food outside the kitchen and they consider as ill-treating to dine in the *dheetti*. This is mainly because, a sort of pollution is attached to the *dheetti* since women during their menstrual period are secluded in a corner of the *dheetti*. So when others are called for food or when relatives visit the *koorai*, they will be invited to the kitchen for eating along with the household members after which they go out and spend time either in the *dheetti* or will sleep in other neighbouring huts.

Just like the children's practice of sleeping in other huts, in certain cases, old couples or widowed parents are seen residing in their own separate hut even though they form part of their children's domestic unit. This will be usually a small hut nearby their children's or other close kin's hut to which they are attached to. Though they reside **in** separate hut, they rarely cook their own food and **will** get major share of their meals from their children's household to which they belong. But at times they do minor cooking like roasting roots and tubers or boiling *tuvari* seeds during the day **time**. Since they are not capable enough to carry out the domestic activity **and** manage the household affairs independently, they **will** remain as dependent members to their close **kin's** household. In such cases, they **will** not be a full-fledged or core members to the household, but remain as partial or marginal members **with** regard to their share of labour **in** domestic activities. However, they may co-operate **with** and assist the household members **in** domestic as well as other agricultural activities. And, **in** case of these attached members having their own farm land, it will be cultivated mainly by the household members to whom he / she **is** attached.

At Thaze-Abbannoor, Kaden's aged and widowed mother **Regi** **is** staying **in** a small hut nearby her son's and daughters' household. Though she **is** residing separately, she **is** attached to the household of her second son Velli and **will** be getting her major share of food from Velli's household. She also gets a share of food and help from the households of other two sons, Kaden and **Panali** and from her daughter **Vellachi**, who are residing near. However, she spends most of the **time** at **Velli's** hut and assist his household members **in** domestic and other agricultural activities. Moreover during 1995 when **Regi's** daughter's daughter Beere and her husband Murugan lost their hut due to heavy storm and rain, they came to stay **in** Regi's hut. At that **time** **Regi** shifted her stay **along with** Velli for a few months becoming a full member of that domestic unit.

All the huts **in** a hamlet **will** be more or **less** similar **in** structure. The members of a household together work for constructing the hut and they are usually constructed very easily. Some times an household may rely on close **kin** for work **like** getting bamboos and dry grass from forest, roofing, thatching, etc. Thus one or two men assisted by two or three women and children working several hours a day for 3 to 4 **days** can construct an average hut.

The Mudugas do not shift their huts and residence very often. Huts will be repaired and re-thatched whenever needed, usually once in two years or so. Though they shift the fields every 2 or 3 years due to the practice of shifting cultivation, they never shift their huts to follow their fields. However, they erect a simple, temporary and crude form of hut in the midst of their farm land to watch the crops from wild animals and birds during the later phase of the crop. The watch hut built in the farmland is called *kava-sala* or *alai*. When the crops are ready, they erect the *sala* in their respective fields and will temporarily shift their stay to this hut for about 3 to 4 months until the harvest is over. However, all the members of the household will not shift to the farm land and during their stay in the fields, they still maintain close interaction with the hamlet. They make frequent visits to the hamlet to look after their huts and other belongings and sometimes to borrow grams and other provisions from their related households. Unlike the clustered pattern of residence in the *ooru*, in the fields they have a sort of dispersed pattern of residence. *Sala* will not be erected closely. But when farm lands of closely related kinsmen especially of brothers are very adjacent, any of the related household will erect the *sala* and one or two members of these related households stay in the farm land to take care of all the closely lying fields. This shifting of residence between the hamlet and the field is well referred in their saying "*Kadaru masam, ooraru masam*", meaning "six months in the hamlet and six months in the fields". After harvest, they come back to their permanent hut in the hamlet. For a period of about 3 to 4 months they live in the watch-house (*sala*) erected in the farmland. However during the day time in this period, people come to the hamlet and engage in other activities and by evening return to their farm land hut. In certain cases, only male members will spend the night time in the farm hut where as women and children will stay back in the main hut itself. In such cases, a close kin like, brother or eldest son may also be with him in the farm hut during night.

The lineal inheritance of land from father to children as well as the need for mutual co-operation and assistance in economic activities make the closely related kinsmen especially, agnates to clear and cultivate adjacent and closely lying lands. Table 2.9 shows the nature of distribution of adjacent farmlands of close kinsmen as in 1996.

Table 4 10 Distribution of Adjacent farm lands of close kin

Type of relationship	F-S	B-B	B-Z	F-D	M-D
Frequency	9	17	10	3	2

An analysis of the pattern of clearing and cultivation of farmlands of 41 households at Thaze-Abbannoor hamlet shows that, in 17 cases, brothers lands which are adjacent to each other, and in 9 cases sons near to their father's land. The Table also shows that in 10 cases sisters are having farmland near to their brothers and in 3 cases daughters have land adjacent to their fathers, and in 2 cases to their mothers.

Food and Sharing The Mudugas are habituated to take only one main meal per day which is cooked in the evening. In the day time most of the people will be away from the hamlet either in their fields or in the forest do not generally get back to their hut and cook food. In the afternoon, usually while working in the farm land, they will satisfy with any light food such as boiled *tuvan* seeds, some tubers or black tea. Even if they are in the hut during day time, they rarely prepare any food and may sometimes boil some roots or tubers and thus satisfy with light meals.

The cooking of food is the main duty of the females. Women are assisted by their grown up female children in preparing the mam meal. They also help by fetching water and fire-woods, washing, pounding grains, etc. Adult males rarely engage in cooking but when women undergo pollution due to monthly menstruation, and if other adult females are absent in the household, husband will engage in cooking for the entire seven days. At this time, he will be assisted by his elder children.

A mam meal, however, is normally prepared once in a day i.e., in the evening. After the cooking is finished, the food is shared in separate plates and is kept aside. All the members in a domestic unit do not generally dine together. Usually father and younger children eat together. Later, grownup females eat their food. Mother will be the last to take food in the family. Usually women will not eat along with males and particularly in

the presence of her son-in-law, father-in-law and husband's elder brother with whom she has avoidance relationship

Among the Mudugas, **the main meal is shared with** other closely related or neighbouring households **with** whom they maintain a food sharing relation. **This** practice is known as *beethe vidyathu* and these linked households who form a food sharing unit are called *beethekarar*. The number of food shares exchanged between two households depend on the number of primary relationship (M, F, B, Z, S, D, **W**, H) existing between these households. Thus for **e g**, if a person's mother lives **with his** younger brother's family, he has to give one share of food to **his** brother's family and one share to **his** mother. Usually 3 or 4 closely related and neighboring households enter **in** such food sharing relationship forming a food-sharing unit. Each of these households also maintain *beethe* relations **with** other households **with** regard to their relationship. Any member of a household if having primary relationship **with** members of another household, **it** may result into *beethe* relationship. Fig 4.20 shows the pattern of *beethe* relationship maintained between different households at Thaze-Abbannoor hamlet.

This sharing of main meals is not of a generalized type, but it is considered as a type of balanced reciprocity and the *beethe* partners are obliged to send their share of food to their respective *beethekarar* in the same quantity every night without **fail**. **This** exchange of *beethe* is primarily based on close kinship relation, and an household maintain or enter in *beethe* relation **with** the households of the primary kin of either the husband, **wife** or even son's wife. **However**, closeness of residence **is** also a factor of *beethe* relation, and thus two households which are specially close usually maintain *beethe* relation even though no members of either units are immediate kin. Similarly, **if** the households of close kin are situated at far distance, they usually **will** not have a regular sharing of food mainly due to lack of convenience, but **will** only maintain sporadic give and take relation **which is** not a regular and obligatory one. Thus, **Ramanan** and **Chithambaran** of Thaze-Abbannoor is having *beethe* relation **with** their younger sister **Maruthi's** household situated nearby **in** the same hamlet. But they are not maintaining the same type of *beethe* relation **with** their another sister **Mathi** residing a little away from the **main** hamlet. The reason behind **this**

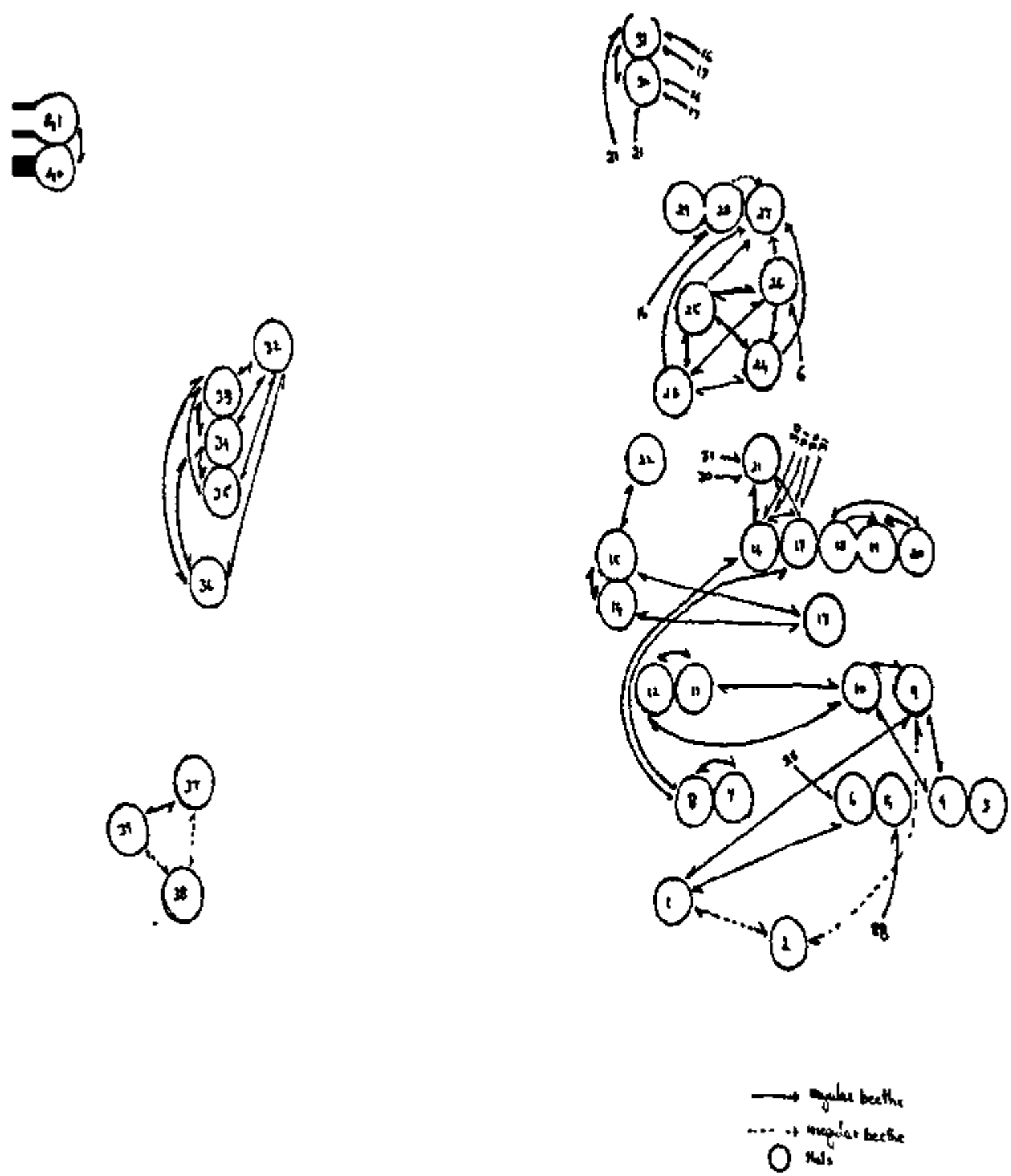

Fig 4 20(a) Pattern of *beehive* exchange at Thaze-Abbannoor hamlet

mainly because of lack of convenience in maintaining regular and frequent contacts between the households

A quarrel or dispute between households disturb the *beethe* relation. Thus, Vellachi of Thaze-Abbannoor (28)¹⁰, who is residing very close to her brothers, Kaden (23), Panah (24), and Velli (25) is not having *beethe* relation with them since her husband Nanjan had a quarrel with his wife's brothers few years back

If in certain case, a member of one household shifts to another household having *beethe* relation, due to marriage, then an additional share of food should be given to the members who have recently shifted to the other household. At Thaze-Abbannoor, Kakki's household is having *beethe* relation with Kakkilinkan's household. But after Kakkilinkan's wife's sister Mathi who was a member of his household, shifted to Kakki's household on marrying to Kakki's son, an additional *beethe* share is given for the couple

It is clearly evident from the figure that, at Thaze-Abbannoor, every household maintains *beethe* relation with atleast one household. An exception to this is of Pariah's household (3) who are presently having no *beethe* share with any other households. Panali explained that they too were earlier having *beethe* shanng with households of Kakki (1), Kali (4), Nanjan (5) and Kakkilinkan (6). But later due to development of minor quarrels between these households and because Panalis and his family stayed away from the hamlet for a period of time, made them unable to proceed with the exchange

There are also cases where a single household gives more than ten *beethe* shares when two or more closely related households join together to form a single domestic unit. At Thaze-Abbannoor, after the death of Ramaswami, his wife Karimi and her children were alone in the *koorai*. So Karimi's mother and two younger sisters, and elder sister Vellachi's domestic unit shifted to Ramaswami's wife's *koorai* and started functioning as one domestic unit cooking together in one hearth, though sleeping in their respective huts. During those days they divided their night meals into sixteen shares including their *beethekarar* and guests. The shanng which took place at Kanmi's household on 17th December, 1996 is as follows: three shares went for Karimi's sister Vellachi's *koorai*, three shares for Kanmi's mother's family and three share for Karimi's household- One share each to Ramaswami's father Kaden, and Ramaswami's father's younger brothers

Velli and Panali One share was given to Ramaswami's father's mother and another one share to Karinns's younger sister Mathi who is married to Kakki's son Raju Ramaswami's FZ" children who came as guests from Thodukki hamlet got one share. That day Karimi's FBS Vella also got a share of night meal (see Fig 4 21)

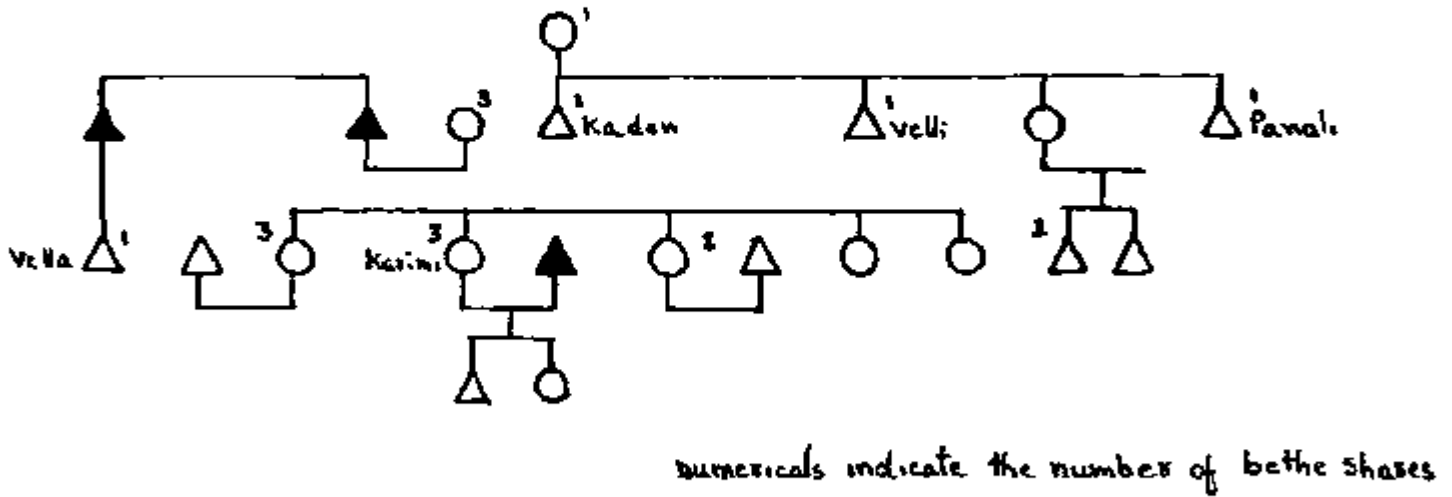

Fig 4 21 Beethe shares from Kanmi's household

It is to be mentioned here that in certain cases, members of a particular household will be having more than one primary or immediate kin relation with another household. In such cases, more than one beethe shares will be given to that household depending on the number of nuclear family units constituted by these relatives in that joint household. However, if all these primary kin constitute only one nuclear family unit in an household, then only one share will be given. Thus at Thaze-Abbannoor, Velli's younger brother Aiyappan has married Velli's wife's younger sister, such that both Velli and his wife are having primary relation with Aiyappan's nuclear household. But only one beethe share is given from Velli's household to Aiyappan's household since the immediate relatives of both husband and wife constitute a single nuclear family.

If parents are residing in a separate hut and maintaining their independent domestic unit, it is the responsibility of their children to give a share of night meal to their old

parents Usually the exchange of food between old parents and their children's households are not of a balanced reciprocity type and sons and daughters rarely expect a share in return If there are more than one son residing nearby, they never assign the obligation of giving food for their parents to any one of them with whom the parents are attached It is each and every son's obligation and duty to give a share of meal to their old parents through which their love and concern to them is expressed The very ideology involved in the nature of Muduga food sharing habit is very well revealed in their saying, "*panki thinnal pajjaarum*", which means "if you share while you eat, your hunger will reduce"

Table 4 11 Type of km relationship existing between *beethekarar* at Thaze-Abbannoor

Sl no	Type of km relationship between <i>beethekarar</i>	Frequency
01	B-Z	15
02	B-B	10
03	M-S	10
04	Z-Z	4
05	M-D	4
06	F-S	3
07	F-D	1
08	F/M-D	1
09	F/M-S	1
10	FB-BS	3
11	FB-BD	2
12	MB-ZS	2
13	FZ-BS	1
14	BW-HB	1
15	ZHZ-BWB	3
16	FM-SS	1
17	HM-SW	1
18	HF-SW	1
19	HFB-BSW	2
20	FFB-BSS	1

This table shows the various types of relations and their frequency existing between households which forms the basis for *beethe* relationship at Thaze-Abbannoor hamlet. Out of the various relationships (both primary and secondary) existing between the different *beeihckaiar* households in the entire hamlet, the maximum number of relations observed is that of B-Z type which numbers 15. The number of *beethe* based on the primary relation of B-B is 10 and of M-S relation is also 10 in number. The number of M-D relations and Z-Z relations are 4 each. Analysis also shows that other secondary kin relations like FB-BS, MB-ZS, FZ-BS, FM-SS, etc., and tertiary kin relations like FFB-BSS, HFB-BSW, etc., also form the basis for *beethe* relationship between households.

Table 4.12 Number of Beethekarar and the type of relation with respect to the head of the household at Thaze-Abbannoor

Sl.no	Head of household	Beethekarar households and the relationship
01	Kakki	(2)S, (6)cl B, SWZ, (9)Z
02	Bokken	(1)F, (9)FZ
03	Panah	-
04	Kali	(9)WF, (10)WB
05	Nanj, an	(29) D
06	Kakkilinkan	(1) cl B, WZ, (26) WM, WZ
07*	Chelli	(8) B
08	Chellan	(7) Z, M, (16) WB, (17) WB
09	Chellan	(1)WB, (2)WBS, (4)D, (10)S
10	Panah	(9)F, (11) WB, (12) WB, (4) Z
11	Kali	(10)Z, (12)B
12	Chiryan	(10) Z, (11) B
13	Man	(14)WB, (15) WM
14	Vella	(13)Z, (15)M
15	Chonke	(14)S, (13)D, (22)BSS
16	Aiyappan	(17) B, (21) WBWB, (30)WBWB, (31) WB, (8) WZ
17	Velli	(16) B, M, (21)WBWB, (30)WBWB, (31)WB, (8)WZ
18	Bokken	(19) M, (20) BS, BW
19	Gundi	-
20	Linkan	(18) FB, FM, (19) FM, HM
21	Ramanan	(16) ZHZ, (17) ZHZ, (30) B, (31) Z, M
22	Chekidan	(15) FFB
23	Kaden	(24) B, (25) B, (26) SW; (27) M
24	Panah	(23) B, (25) B; (26) BSW, (27) M
25	Velli	(23) B, (24) B; (26) BSW, (27) M

26	Karimi	(23) HF, (24) HFB, (25) HFB; (27) HFM; (6) Z
27	Regi	-
28	Nanjan	(29)S
29	Rangan	(5)WP
30	Chitambaram	(16) ZHZ, (17) ZHZ, (21) B, (31) Z,M
31	Kullan	(16) Z; (17) Z; (21) WB, (30) WB
32	Rangan	(33) WB, (34) FB; (35) FB, (36) Z
33	Kullan	(32) Z, (34) MB, (35) MB, (36) ZHZ
34	Kali	(32) BS, (33) ZS,Z (35) B, M (36) BD
35	Linkan	(32) BS, (33) ZS,Z (34) B (36) BD
36	Rangan	(32) WB, (33) WBWB, (34) WFB, (35) WFB
37	Nanjappan	(38) Wcl B, (39) Wcl B
38	Maruthan	(37) cl ZH, (39) B
39	Vellinkiri	(37) cl ZH, (38) B
40	Enyan	(41) F,B
41	Mallan	(40) S

numencals **in** bracket represent hut number
 * represents female headed household

Regarding *beethe* sharing, the food should be sent to the related households regularly without fail and there will be strict account of the flow of food between households. The same amount of food will be reciprocated. Lack of any reciprocation over time from any related household would lead to resentment and breaking up of this sharing link. Women take special care to send the *beethe* share to the related households immediately after the cooking is over without any delay. Usually children will be sent to give the food to the neighbouring hut and in turn they will come with the share from that hut. Before the exchange of food, children will come and collect the plate (*beethe-kinnam*) from the respective hut to bring their *beethe* share. Sometimes they will give the *beethe* share in their own plate which will be given back in the next day.

It is important to point out that these *beethe* sharing households will not only be related through the mutual sharing of meals, but also engage in the mutual exchange of labour, co-operation and participation in other economic activities forming a close kin unit. From a close observation of different households in a hamlet, it is evident that 3 to 4 related households are always linked together through this bond of mutual exchange of food and labour composed of either close siblings or even close affines living in the same

hamlet. Thus it is the component families of the *beethekarar* unit which co-operate together at times of economic needs which cannot be carried out by members of a single household. But in cases, if the labour power required by a particular household is more, and finds difficult to manage with the closely related households (*beethekarar*), they recruit some more related households other than the *beethekarar*.

Ramanan of Thazc-Abbannoor is having close interaction with his younger brother Chithabaran's and sister Maruthi's *koorai* who are his *beethekarar* with whom he is having mutual exchange of labour and food. For almost all economic activities, these three units co-operate together as a single unit. But in certain cases when the labour required is more, the boundary of the kin circle widens such as to include some more households which belongs to a second order with regard to kinship and degree of day to day interaction. This second order household includes Ramanan's classificatory brother Veeran's household, Ramanan's another sister Mathi residing little away from the main hamlet with whom there is no daily interaction (see Fig 4 22)

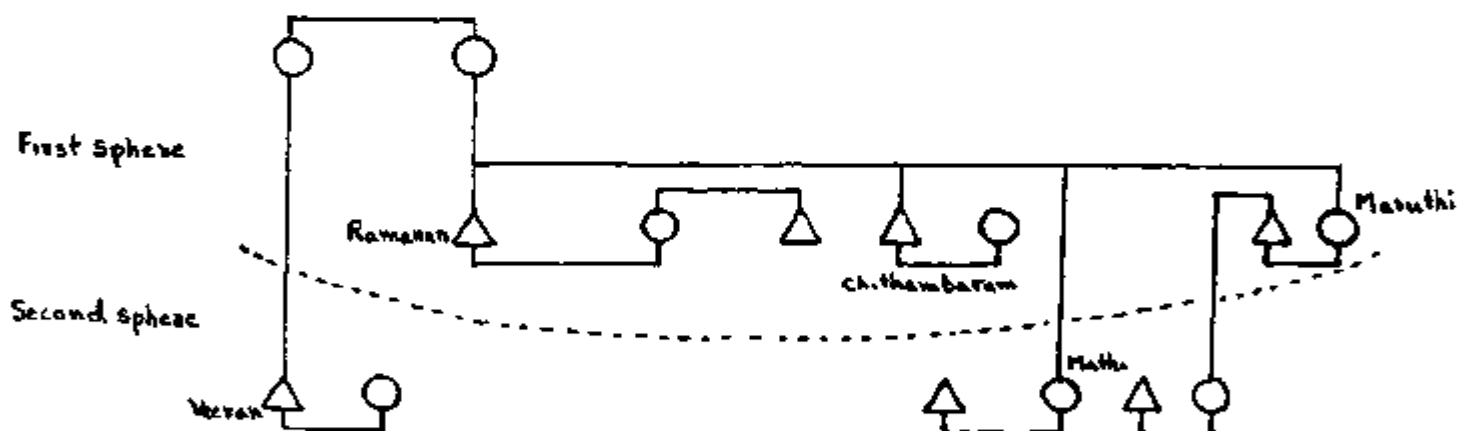

Fig 4 22 Different spheres of economic co-operation of Ramanan's household

Similarly, it is significant to mention here about the sharing of food other than the regular one, and the widening of food sharing unit. Thus on certain occasions, especially when they cook something special, or when they get a fairly good hunt, the circle of sharing widens to include more relatives other than the regular *beethekarar*. In one case at Thaze-Abbannoor, when Panali got a **wild** deer, he shared out the meat to **his** close relatives apart from the regular food sharers. The sharers of the meat included households of **his** regular *beethekarar* such as, **his** elder brothers Kaden and **Velli**, **his** mother **Regi**, **his** elder brother's son Ramaswami and also **his** sister **Vellachi** (with whom he is maintaining irregular *beethe* relationship). Other than these close km, Panali gave shares to **his** classificatory brothers, **Kali** and **Chiryan**, classificatory sister, classificatory mother's brother and also **his** elder sister's son, who fall outside the circle of regular *beethekarar*.

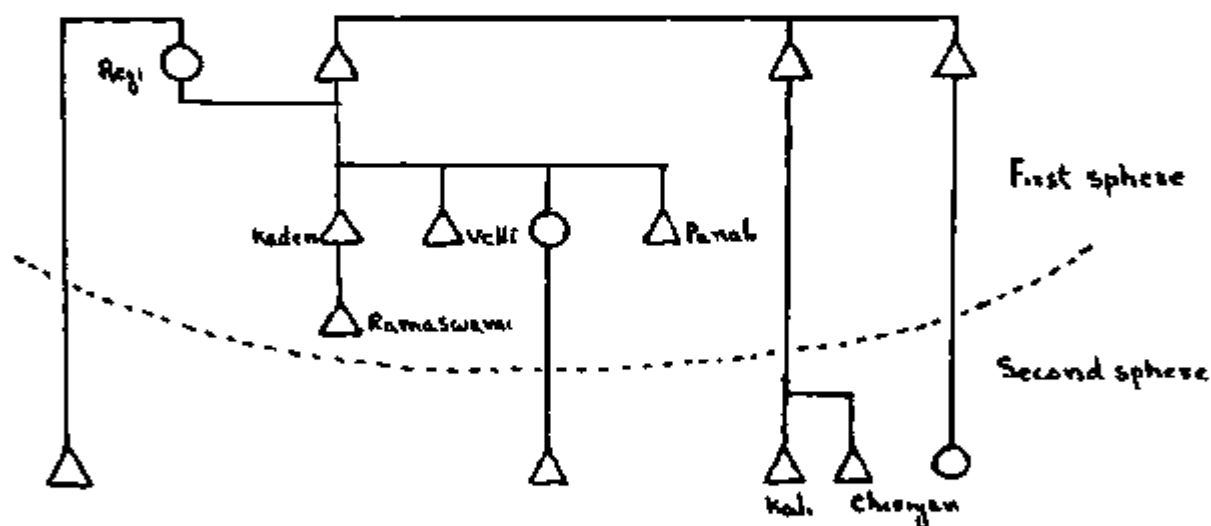

Fig 4 23 Different spheres of food shannng unit of Panali

There are also cases where members other than the regular *beethekarar* get a share of food regularly for rendering service to the household. At Thaze-Abbannoor, **Mannan**, son of *bandari Velli* is herding catties for **Kakki**, and he is getting food regularly from **Kakki's** hut. This cannot be equated with *beethe*, since there takes place no mutual sharing of food in the household level.

Other than the main meal prepared during evening, there are also simple meals which require little labour and may be prepared anywhere and at any time. Thus during day time, whenever they happen to get some tubers or roots and feel like eating, they put fire, cook and eat it. This irregularly prepared food at any time of the day is not exchanged to other households. There is no such obligation with regard to this simple meals.

When a woman individually cooks a simple meal, she does not distribute any of it away from the place she has made it. However, she offers to share her food with other women or children who may be present, whether or not they are members of her domestic group or members living nearby. Such offering to share is a matter of courtesy and there is no much obligation attached to it. During day time, mostly male members of the household will be absent in the hamlet and whatever simple food prepared during day time will not be kept for those who are not present at the time of preparation. Thus people do not consider it very strict to share the simple meal prepared during day time to all the members of the household.

Development cycle of domestic group

Fortes' (1958) discussion of the development cycle of domestic group clearly depicts the various successive stages of the maturation of a new member of society, from totally dependent infant to totally independent adult who himself leads a domestic group, fully contribute to its subsistence and begets new members to the family. The development cycle is a way of conceptualizing the articulation of individual maturation with the career of the domestic group. Each domestic group comes into being, grows and expands through a regular sequence of phases, and is finally dissolved and replaced by the original type.

Birth, Marriage, and death in the individual life cycle are considered as prime factors which alters the composition of an household through the process of expansion,

dispersion, and dissolution According to Fortes (1958 4-5). the phase of expansion lasts from the marriage of two people until the completion of their family of procreation The phase of dispersion or fission begins with the marriage of the oldest child and continues until all the children are married The last phase, i.e., replacement, starts when the youngest child remains to take over the family and ends with the death of the parents, thereby replacing their family by the children's family

However, other social factors such as merging of closely related households, separation of households, attachment of dependent members, brief duration of conjugal relations, etc., are also factors which make for the shift of persons between domestic units and thereby altering the composition of households

The first stage in the development cycle of domestic group is the nuclear family consisting or composed of husband and wife with children Here in this initial stage, the sole or entire subsistence activity of the domestic unit revolves round the parents, i.e., the husband and wife of the household Young children are fully dependent on their parents and they are not matured enough to contribute labour to the subsistence of the household ¹¹

When the children grow up, they become capable of assisting their parents in various economic and domestic activities like fetching water, collecting roots, tubers and fire-woods, herding cattle, pounding grams, etc At this stage the children bear a share of labour though not fully, for the subsistence of the domestic group

Later when the children are fully matured, they are capable enough to contribute a full share of labour equal to their parents Then takes place a pooling of equal share of labour from both parents and the matured children who participate with the parents in the economic and domestic activities of the household and share the group's responsibility equally At this stage the children are old enough to participate fully in subsistence activities and to take up all sex-linked tasks of the male or female side of the domestic partnership Thus children are no more dependent on their parents

The household which was composed of a single nuclear family will enter into a new stage, and type of composition changes with the marriage of the elder children. When the son after marriage stays with his wife along with his parents family, the household will change into the type of lineal joint family Now the domestic unit consist of father

and mother, married children and wife and grown up unmarried children. At this stage almost all members of the household are capable of contributing to the subsistence of the group and all of them pool their share of labour for carrying out the domestic activity of the household. In a later stage when the young siblings are ready for marriage, the elder son **will** separate from the parents **unit** along with **his wife** and establish **his** own independent domestic **unit**. Now, the parents of the domestic **unit** become older and weak and are less able to do hard work. The younger children **with** their spouse **live** with their older parents and take care of them **in** their old age. At this phase, the parents are depended on the children who contribute fully for the subsistence of the group. Thus the parents are replaced by the children **in** this stage. In certain cases **if** the old parents are capable of leading an independent domestic unit, the son along **with his wife** **will** separate from them and start their independent family. But however, **this** cases are very rare. Even **if** old parents remain as an independent viable **unit**, on the death of any of the spouse, the other **will** attach to the domestic **unit** of their son.

Some times, the eldest son **with his** family continue to stay along **with** the parents, even after the marriage of **his** younger sibling. **This** tendency of living together and sharing of labour **give rise** to the form of a lineal collateral household. However there are only very few cases of such type. Thus at **this** stage, the domestic **unit** **will** be composed of old parents, son and **his wife** with or without children. With the birth of children for the son, the household constitutes members of three generations-husband and **wife**, their dependent parents and also dependent children. The death of either of the old parents further changes the composition of the domestic group from lineal joint household to the form of paternal extended nuclear family. And still later **with** the death of the dependent **widow / widower**, the domestic **unit** get back to the initial stage of the nuclear family type and thereby the cycle **is** completed.

It **is** evident from Table 4.13 that the Muduga families show a considerable variation **in** their composition. **This** variation correctly shows the Muduga families at different stages of development from a household consisting of a single married couple at one extreme to those of lineally or collaterally extended families at the **other**. The development stages and transformation **in** Muduga household can be illustrated **with** the case of Patti's household at Anakkal **ooru**.

Patti married Veliachi from Thaze-Kakkupadi *ooru* and they begot three children . The elder two are males - Rangan and Kali, and the youngest is a female, Man. This constitute an nuclear family The mamage of Ragan **with Kurumbi** form **kadukumanna** hamlet changed **it into** a lineal joint family But when Rangan built a small hut near **his** father's hut and shifted **with his wife** to that, the lineal joint family broke **into two** elementary families Consequently, Patti's household have only four members viz., Patti and **his wife Vellachi** and their children **Kali** and Man Later Man was married to Marulhan of Thundoor hamlet, which further decreased the members of the natal household to three After that **Kali** married **Maruthan's** sister Man from Thundoor hamlet to again make Patti's household into a lineally joint family

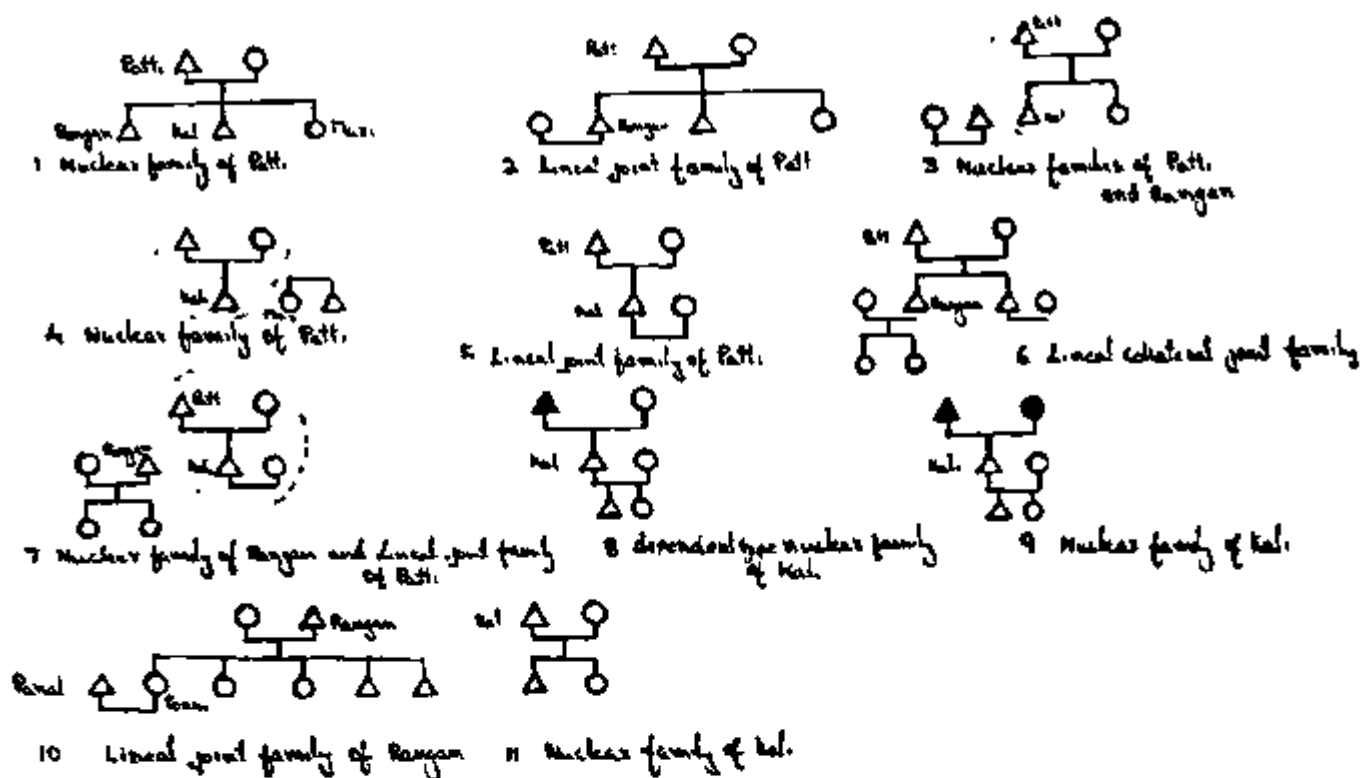

Fig 4 24 Genealogical composition of different stages in the development cycle of Patti's domestic group.

At this stage, Rangan found it very difficult to live in his hut as it was very small and unsafe during rainy season. Hence, he shifted back to his father's house with his wife and daughters. As a result, the lineal joint family household of Patti got transformed into a lineally collateral joint family. But this was short lived. Since it was a very small dwelling, Kali after some time shifted with his wife and parents to another hut built by him to enable his brother to live comfortably with his growing nuclear family in his father's original house. When asked, Kali said that his brother is already having children and that he has more responsibilities and hence it is better that he is left alone with his family. In fact Kali gave up his father's house which ought to have been inherited by him according to Muduga custom. The lineal collateral joint family household of Patti again splits into the lineal family and the nuclear family of Rangan.

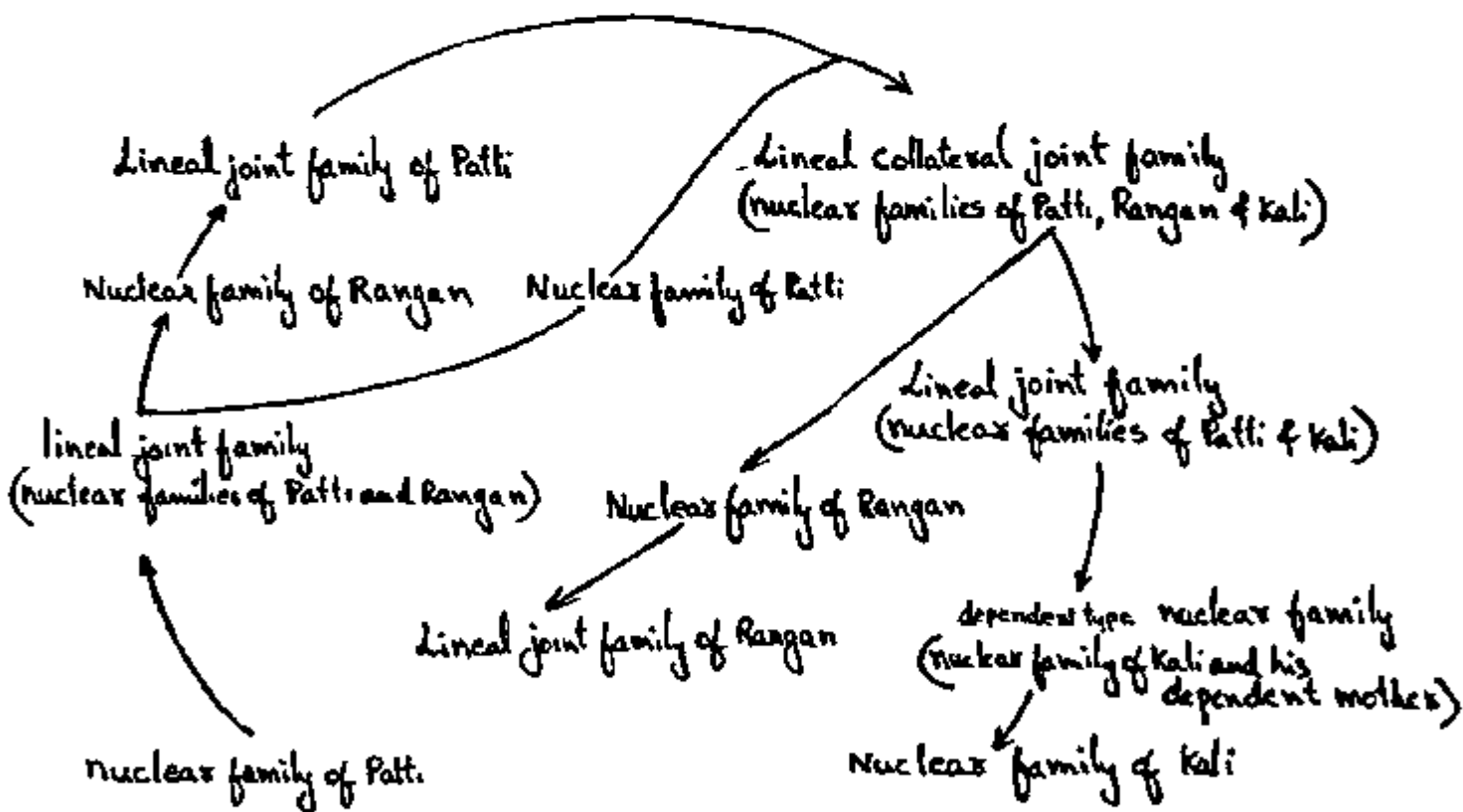

FIG 4 25 Transitional stages of Patti's household

After few years, Kali's father died and at that time Kali had two children. The household then was composed of Kali, his wife and children along with his dependent mother giving rise to a nuclear family with dependent type. By this time Kali's brother Rangan shifted his residence from the *ooru* to his farmland and erected a hut in the field and lived along with his wife and children. Thus Kali with **his** wife and children along with **his** old mother returned to **Patti's** original house. Later Kali's mother also **expired**, thereby transforming the household to the nuclear family type. After this, both Rangan and **Kali** were living separately heading their independent elementary households. Still later, Rangan's elder daughter **Ponni** got **married** to **Panali** of Thaze-Abbannoor hamlet and now **Panali with his wife Ponni is** residing **uxorilocally** along with Rangan's family making Rangan's household **into** a lineally joint family type.

The above case of the growth and development of Patti's and **his** son's household manifests all the important and major phases **like** expansion, dispersion, and replacement enumerated by Fortes (1958). The Muduga family exhibits continuity through **time**, as one elementary family grows out of and succeeds another **in** an unbroken sequence. Thus as Freeman says "although birth, **adoption**, marriage, and death do result **in** regular change **in** its personnel, the family does persist through time as a perennial corporate group" (1951: 24).

NOTES

- 1 For the purpose of distinguishing family from household, U.N. Multilingual Demographic Dictionary (U.N Publications Sales No.E.58), (XIII,4) P.4, quoted in Methods of protecting Households and Families, Population Studies, Manual VII (New York UN Publications 1973), PP 5-6, defines household as Socio-economic units, consisting of individuals who **live** together, while **it** defines family primarily by reference to relationship which pertain to or arise from reproductive process and which are regulated by law or custom Shah (1973) points out that "the household **is** one of the several dimension of the family and should be viewed **in** relation to the other dimensions," (p 3) It **is** the activities or **functions** of the persons comprising a group, he says, which characterise the household
- 2 Bender (1967), makes distinction between families, co-residential groups and domestic functions He says that the term household **is** always tainted by an implicit association **with** certain domestic functions Bender defines domestic activities as those that "are concerned **with** the day-to-day necessities of living including the provision and preparation of food and the care of children" (p 499)
- 3 In a review on family and household as analysis of domestic groups, Yanagisako contends that, "the units we label as families are undesirably about more than procreation and socialization They are as much about production, exchange, power, inequality, and status" (1979 199) According to her, the composition and structure of family and household varies within one society and also from society to society mainly due to three sets of variables - demographic, economic and stratification variables In her review, Yanagisako points out **that, our aim is** to understand the function of the family specific to particular society and culture and for **this** we should "abandon our search for the irreducible core of the family and **its** universal definition" (Ibid 200)
- 4 The term *kudi* **is** also used by the people, though rarely, to refer to mainly households in a hamlet.

- 5 Some writers (Barnard and Good 1984 , Kopytoff 1977) treat households as the separate units in the domestic economy and often distinguish by possession of distinct cooking facilities from homesteads, or physically distinct living quarters
- 6 Regarding the composition of commensal unit or households, Kolenda distinguishes 12 different types (1968 - 346-347) But her typology is not a comprehensive one and there remains unexplained families giving rise to the residential type, 'other families'. Moreover, various possibilities of the major types are clubbed together under the type supplemented See also Barnard and Good (1984 , 83-84)
- 7 This unit consist of members not strictly related through descent only, but persons closely related through descent as well as alliance and also persons residing nearby
- 8 Vellinkiri had married Kade and is living with his wife and children at Thaze-Abbannoor Though Vellinkiri established conjugal relation with Mallika of Pottikkal hamlet and started living with her, he is still maintaining the same relation with his first wife and her children Vellinkiri visits Malhka every week and spends two or three days with her and will come back to Thaze-Abbannoor to stay with his first wife and children Kade is not disturbed or embarrassed knowing this new relation of her husband According to Kade, even if Vellinkiri maintains another wife, it does not matter her much unless he abandons her and the children, but must take care of their family Few people equated Vellinkiri's incident to that of a kitchen hearth, by saying, "*ore kudiya man ippu rantu kudiya uattu*", meaning "one hearth has now changed into two hearth "
- 9 Some Anthropologists (Spiro 1977) argues that the existence of a high percentage of extended families indicates that corporate (highly structured) groups are an important part of the social structure But the opposite "loose structure" thesis holds that these extended families are not an index of the importance of corporate groups in social structure, because they are typically adhoc and temporary solution to interferences in life and domestic cycles, rather than prescriptive or preferential arrangements, based on normative structural principles The deviations from their nuclear family ideal represent for the most part structural solutions to problems created by death and divorce, aging, etc

- 10 The numericals in bracket refers to the hut number as presented in Fig 4 20 A Regarding the composition of commensal unit or households, Kolenda distinguishes 12 different types (1968 . 346-347) See also Barnard and Good (1984 : 83)
- 11 According to Shah (1974), the developmental process is not cyclic but moves in progression towards and regression from the 'dominant norm' and every household represents one of the phases in this development, and the "development process is dependent not only on the demographic factors of birth, marriage, and death but also on the norms of residence and the degree of observance of the norms" (ibid 155)

KINSHIP TERMINOLOGY AND BEHAVIOUR PATTERN

The structure of Muduga kinship terminology conforms to the Dravidian type which is referred as a two-section system. One of the most distinct features of this system is its systematic depiction of the rule of prescriptive bilateral cross—cousin marriage. It has been hence noted for its association with symmetric **cross—cousin** marriage where cross-cousins of both father's side (patnlateral **cross—cousin**) and mother's side (**matrilateral cross—cousin**) are marriageable category equated through a single **kin** term. Thus, for a male ego, the MBD and FZD (**cross—cousins**) are the prescriptive persons to marry, while his FBD and MZD (parallel cousins) are forbidden. The permitted or prescribed spouse need not be a first or real **cross—cousin** in any genealogical sense, but rather any person standing in that terminological category, relative to ego. A man will usually prefer to marry a cross—cousin who is junior to him and a woman marries a male **cross—cousin** senior to her. However, there is no terminological distinction with respect to age among the cross—cousins.

The classificatory **kin** terminology and the distinction into **km** categories are derived by various structural principles, such as a) cross / parallel distinction b) distinction of generation marked by five—generational levels, viz, grand-parents (G2), parents (G1) ego's (G0), children's (G-1) and grand-children's (G-2) c) distinction of sex - male and female d) distinction of relative **age—elder/younger**. Among these four organizing principles, the first one, which is the fundamental aspect of **kin** categorical frame work, divides the entire relatives into two halves or sections in all the generations except the ego's second ascending (G2) and second descending (G-2) generations. These sections are broadly categorized as *anna—thampi* category and *macha—maman* category. The term *anna—thampi* literally means, "elder **brother—younger** brother", and it refers to agnates, while *macha—maman* meaning "wife's brother sister's **husband—mother's** brother" refers to affines. The former category implies **consanguine** and are referred as parallel relatives with whom marriages are prohibited.

Table 5 1 Muduga kinship Terminology

Terms of kin category	Genealogical denotata
Pattan	FFF, MFF, FMF, MMF
Patti	FFM, MFM, EMM, MMM
Acchan	FF, MF, FFB, MFB, FMB. MMB
Acchi	F
Appan	FcB, MeZH
Balliappan	FyB, MyZH
Sinnappan	M
Auvai	
Balliauvai	MeZH FcBW
Sinnauvai	MyZ FyBW
Maman	MB, FZH, WF, HF
Thaimaman	MB (mother's primary brother)
Mami	FZ, MBW, WM, MM
Thaimami	FZ (Father's primary sister)
Annan	eB, FBSc, MZSc, WcZH, HcZH
Akka	eZ, FBDc, MZDc, WeBW, HeBW
Thampi	yB, FBSc, MZSc, WeZH, HeBW
Thanke	yZ, FBDy, MZSy, WyZH, HyZH
Machan	MBS, FZS, WB, ZH, HyB, eZH (fs)
Attiai	MBD, FZD, HZ, WyZ, BW, eBW (ms)
Konthan (fs)	HeB, YZH
Konthi (ms)	WeZ, yZH
Makam	S,BSms, ZS fs, WZS, HBS
Maka	D,BDms, ZDfs, WZD, HBD
Barmakam	ZSms, BD, fs, WBD, HZD, SW
Barmaka	ZDms, BD,fs, WBD, HZD, SW
Peram	SS DS BSS. ZSS, BDS. ZDS
Perathi	SD, DD, BSD, ZSD, BDD, ZDD

G ²	acchan	acchi	acchan	acchi
G ¹	baliappan	mamu	maman	baliavvai
	appan			avvai
G ⁰	annan	akka	mochan	attai
	thampi	thanke		
G ¹	makan	maka	barmakan	basmaka
G ²	pesan	pesathi	pesan	pesathi

Fig 5 1 Structure of Muduga kinship terminology

The latter category, the *macha—maman*. implies affinity and marriageability and are referred as cross-relatives. This characteristic feature of dividing the entire community or kinsmen into two halves of parallel and cross relatives made it to depict the two section system¹. Though the whole set of kin categories are divided into two sections as consanguines and affines, in ego's second ascending and second descending generations, the distinction is ignored. Thus there are only two terms in these levels showing the sex distinction, and the cross-parallel distinction remains neutralized.

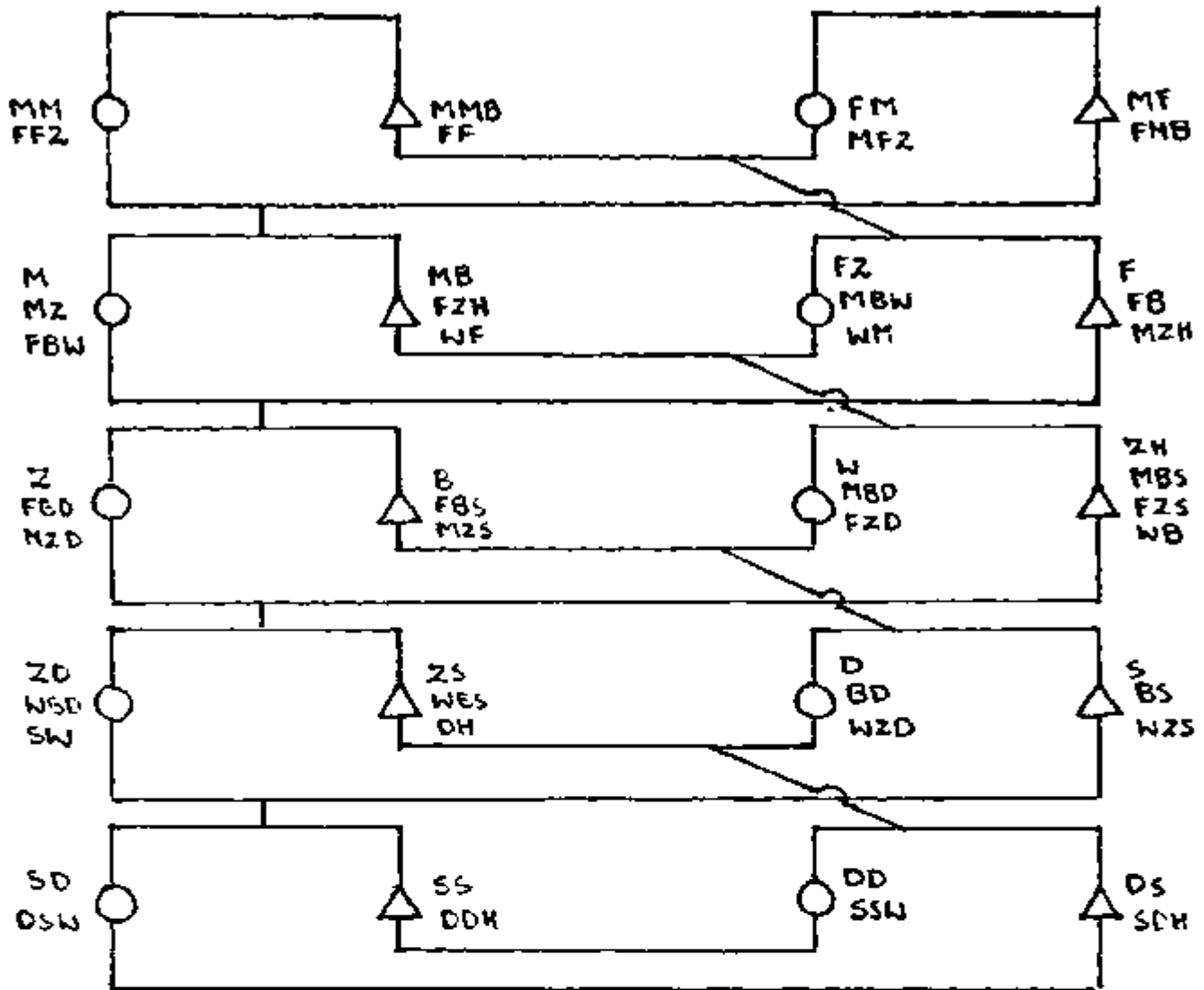

Fig 5 2 Muduga kin terminological structure depicting the rule of bilateral cross-cousin marriage

In the first ascending generation, the structural principles of cross/parallel distinction and sex distinction work together to give two male and two female km terms opposing each other and implying marriageability as shown in Fig 5 3. The kin terms *auvai*, *balhauvai*, *sinnauvai* are used to refer mother, mother's elder sister (father's elder brother's **wife**), and mother's younger sister (father's younger brother's **wife**) respectively, and equivalents of these positions as against the term *mami* which denotes father's sister, mother's brother's **wife**, wife's mother and husband's mother and other equivalents of such relatives. The terms *appan*, *balliappan*, *sinnappan* are used to refer father, father's elder brother (mother's elder **sister's** husband) and **father's** younger

brother (mother's younger sister's husband) respectively, and equivalents of these positions. The term *maman* refers to mother's brother, father's sister's husband, wife's father and husband's father and equivalents to them. In ego's first ascending generation, mention need to be made about the genealogically identified terms like *thaimaman* (mother's own brother) and *thaimanu* (father's own sister). These terms denote the closer genealogical referent in the kin structure and hence a single meaning unlike others which are categorical identities that denote several genealogical positions in the kin structure terminological paradigm.

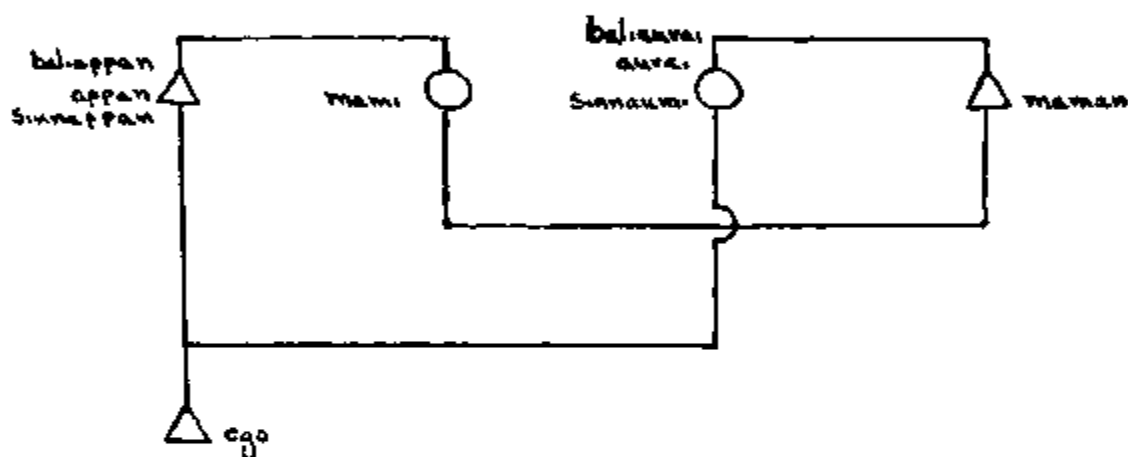

Fig 5 3 Marriageability between members of first ascending generation

The criterion of relative age is thus found to operate in the first ascending generation where the senior parallel relatives are distinguished from their junior relatives by the prefix *ballia*² for elder and *sinna* for younger along with *appan* (father) and *auvai* (mother) as the root term. However, this structural principle of age distinction is not operating totally in the first ascending generation. Thus there is no terminological distinction made among elder and younger father's sisters and also among elder and younger mother's brothers and hence no prefix is added to these two terms.

Moreover, in the first ascending generation, there is the merging of father's same-sex siblings. Thus father's elder and younger brothers are seen equated with the spouses of mother's elder and younger sisters respectively. Similarly, mother's elder and younger sisters are equated with spouses of father's elder brother and younger brother respectively. The children of all these relatives are parallel cousins to ego. They are considered almost as their own brothers and sisters, behaviorally as well as terminologically. The genealogical equations operating here in the first ascending generation are

$$FeB = MeZH$$

$$FyB = MyZH$$

$$FeBW = MeZ$$

$$FyBW = MyZ$$

Another feature of the terminology is that, an ego uses the term *appan* or *auvai* only to address his real father and mother who is his father. He will address his father's wife (who is not his real mother) as either *balliauvai* or *sinnauvai* depending on the age difference, and not by the term *auvai*. Similarly, mother's husband (who is not the genitor) will be addressed as either *balliappan* or *sinnappan*, and not by the term *appan*. However, the terms *appan* and *auvai* are used in certain cases as reference terms for persons other than the genitor but those equivalent to them. The equivalence of MB (*maman*) with FZH, WF and HF and of FZ (*mami*) with MBW, WM and HM clearly depicts the rule of bilateral cross - cousin marriage.

In ego's generation also, the criteria of sex and cross / parallel distinction operate to give two sets of male and two sets of female terms opposing each other and implying

marriageable relation as shown in Fig 5 4 This also clearly depicts the division of parallel and cross-relatives which results in the separation of siblings and cross—cousins. More over, as seen in the first ascending **generation**, in ego's generation also, the structural principle of relative age operates making clear distinction between senior and junior relatives Thus, analogous to the distinction of **generation**, there can be seen a split in ego's generation into two distinguishing relatives older and younger than ego, and different terms are used to differentiate them. But unlike in ego's first ascending generation, here in ego's generation, the distinction of age is marked not by prefixed adjectives, but by distinct terms

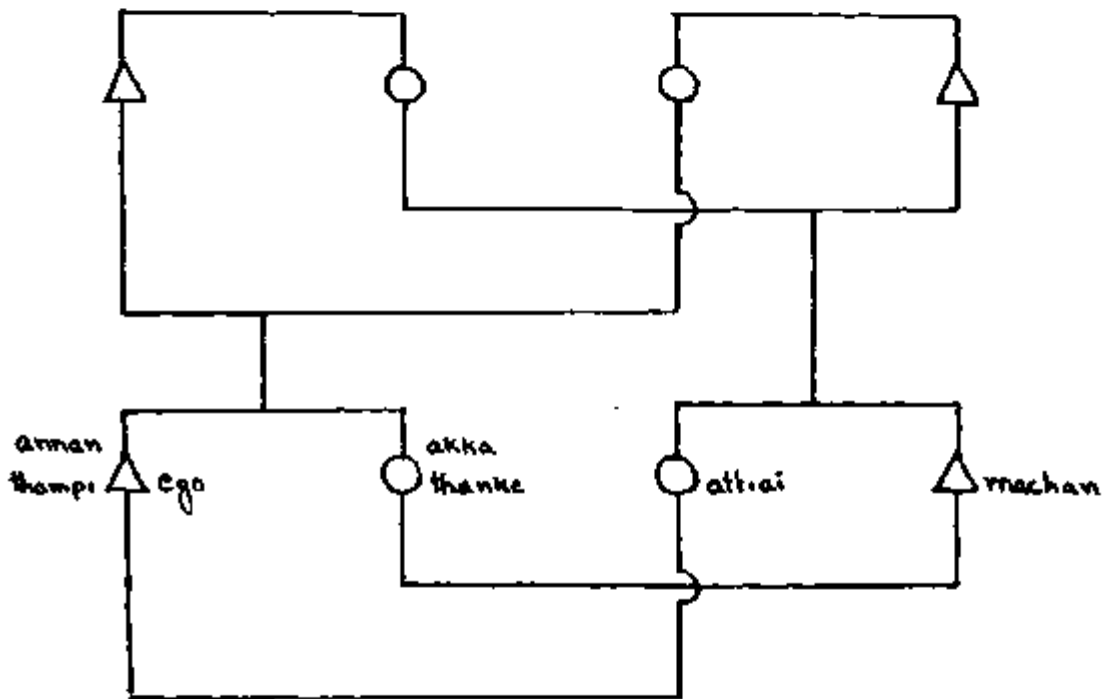

Fig 5 4. Marriageability between members of ego' generation

The terms *annan* and *thampi* refer to elder and younger brothers respectively and their equivalents like father's brother's son and mother's sister's son. Similarly, the term *akka* is used to denote sister, father's brother's daughter and mother's sister's daughter who are elder to ego. The term *thanke* is used to refer sister, father's brother's daughter and mother's sister's daughter who are younger to ego. This distinction of relative age operates only among the parallel relatives and there is no terminological differentiation or separate categories depicting the age distinction among the cross relatives in the ego's generation. Thus the term *machan* refers to male cross-cousin and *attiai* refers to female cross-cousin. All cross-cousins which includes FZS and MBS both elder and younger are referred by the term *machan* irrespective of male / female distinction of the speaker. Similarly, all female cross relatives in ego's generation which includes FZD and MBD both elder and younger are referred as *attiai*.

The distinction of relative age most prominently appears when it does among the parallel relatives and it seems to be entirely absent among cross relatives. Thus according to Trautmann, "the distinction of relative age among categories of kin serves social relations of subordination and super ordination, . . . cross kin are **affines** of a **kind**, with whom one is in a social relation of reciprocity, . . . the e / y distinction suggests that among parallel kin with whom one's relation is otherwise one of mere identity, the e / y distinction intrudes to **give** relief to an otherwise flat landscape, and to organize it internally on a basis of hierarchy" (1981 : 46 -47)

However, it is to be mentioned here that a major problem with regard to the **cross/parallel** distinction in the first ascending generation is with the position of M and FZ. Though the grouping of mother in the cross category along with **mother's** brother and father's sister in the parallel category along with father is in structural correlation with the Muduga kinship, in the actual behaviour, mother and father's sister tend to get identified more with their spouses as parallel relative and cross relative respectively. Thus the principle of relative age operating among the 'fathers' also get extended to the '**mothers**'. On this same logic of **extension**, there operates no age distinction among the 'father's sister **like** among the mother's brother. Though the principle of relative age operates mainly among the parallel **relatives** and is absent among the cross-relatives, there is no greater logic in treating it as a dimension of parallel category. Rather, the operation of **relative** age can

be considered only as a compound of the dimension of lineal relatives (father and mother), and the elder/younger distinction among non-lineal relatives (MB and FZ) is weak and secondary to the lineal/non lineal distinction

Another major dimension of the operation of relative age **is** the closeness among relatives. Genealogical closeness and **frequent** interaction through residential unity (since F and FB are co-residents, their spouses — FW=M and FBW=MZ are also **co-residents** of the same hamlet) makes for the necessity of a terminological distinction among these relatives, based on relative age. Thus the dimension of relative age is never a dimension of parallel category but **is in** fact a dimension of **lineality** and genealogical closeness.

The **ballia/sinnad** distinction that operates **in** ego's first ascending generation can be considered as another instance of the elder / younger distinction operating **in** ego's generation. All those whom ego's father calls **his annan** or **thampi**, ego refers as **balhappan** or **sinnappan** respectively, and all those whom ego's mother calls her **akka** or **thanke**, ego refers as **balliauvai** or **sinnauvai** respectively.

Though there **is** no terminological distinction as such between elder cross-cousins and younger **cross-cousins**, **it is** to be mentioned here that, distinctions are made for those **cross-cousins** who are immediately related through **marriage** and **with** whom there exist avoidance relationship. Thus after marriage, even **cross-cousins** are referred by new terms because of the compulsions of avoidance relationship, specific to the category **into** which they fall. Thus, WeZ and yBW are referred as **konthi** by a male ego, and HeB and yZH are referred as **konthan** by a female ego. The **kin** terms **konthan** and **konthi** are reciprocal terms to each other. Sex of the speaker **is** an important criterion so far as the affines of the same generation immediately related through marriage are concerned. The **rule** of avoidance relation **is** such that, for both male and female ego, same-sex younger sibling's spouse and spouse's same-sex elder siblings are **in** avoidance relationship.

Konthi = SS y sb Sp (m sp), Sp SS e sb (m sp)

Konthan = SS y sb . Sp (**f.sp**); Sp SS e sb. (**f.sp**)

A male ego refers **his** wife's elder sister as *konthi* and he **will** not address her, since there exist **high** degree of avoidance **between** them (WeZ and **ZyB**). But he refers **his wife's** younger sister as *attiai* and addresses her by the same term or by name. A male

ego refers his elder brother's wife as *attiai* and also addresses her by the same term. They behave more friendly with each other. Joking relation exist between them. He refers his younger brother's wife as *konthi* and will not address her with any term since they avoid each other. It should be mentioned here that, if a male ego's wife's younger sister (*attiai*), **with** whom he **is** having joking relation, marries **his** younger brother, then there **will** be a change **in** the **kin** term and there after she **will** be referred as *konthi* and the relationship between them also shift from **joking** to that of an avoidance behaviour.

A female ego refers to her husband's elder brother as *konthan* and she **will** not address **him** by any term since there exist **high** degree of avoidance between them. But, she refers her husband's younger brother as *machan* and addresses **him** using the same term or by name. The relationship between HyB and eBW **is** of **friendly** and joking nature. Elder sister's husband **will** be referred by a female ego as *machan* and use the same term to address **him**. The relationship between them **is** of a friendly type and **joking** relation exist between them. A female ego **will** refer her younger husband as *konthan* and **will** not address **him** using any term since there exist **high** degree of avoidance between them. If a female ego's husband's younger brother whom she refers *machan* and **with** whom there exist joking relation, **marries** her younger sister, then he **will** be referred as *konthan* and there after the relationship between them shift from joking to that of an avoidance behaviour.

A male ego refers both **his** ZH (elder and younger) and WB (elder and younger) as *machan*. Similarly, a female ego refers both her BW (elder and younger) and HZ (elder and younger) as *attiai*. Both male and female ego refers their elder brother's **wife** and elder sister's husband as *attiai* and *machan* respectively.

The equivalence rule working **in** the **kin** terminological system shows that the spouses of siblings are considered as siblings to one another. Thus members of different descent groups who have taken or given brides to the same descent group are classified together as parallel relatives.

The equivalence of the consanguineal and affinal **kin** positions **in** ego's same generation **into two** sets of parallel and cross relationships can be shown **in** the following equations

Parallel relatives

$$B = FBS = MZS = WZH = HZH$$
$$Z = FBD = MZD = HBW = WBW$$

Cross relatives

$$H = MBS = FZS = ZH = WB$$
$$W = MBD = FZD = BW = WZ$$

The above equations accord well with the rule of bilateral **cross-cousin** marriage and the concomitant prohibitions of parallel **cousin marriage**.

The Muduga kinship terminology shows that there **is** no separate km terms used for persons related through marriage who were not **cross-cousins**. These affines related through marriage are equated with cross-cousins through the same km term used for cross-cousins revealing that **cross-cousins** are potential spouses to one another

The structure of Muduga kinship terminology shows that there **is** no status difference between **cross-cousins** i.e., MB' children and FZ' children. Similarly, ZH and WB are considered equal and are equated through the km term *machan*. However, from the behavioural point of view, it **is** observed that one's ZH **is** given more respect and concern than one's WB. This variation in behavioural pattern can be explained as one caused due to the influence of the nature of sibling solidarity existing among the Mudugas. It **is** significant particularly to note that, since in ego's generation, there **is** no depiction of age distinction in km terms for the affines, a male ego can marry **his** female **cross-cousin** referred as *attiai* and a female ego can marry her male **cross-cousin** referred as *machan*. As far as Mudugas are concerned, there **is** no terminological categorization into marriageable **cross-cousins** and non-marriageable **cross-cousins** and thus for an ego, the 'terminological prescribed category' **is** the cross relative of **his** own terminological level.³ Nevertheless, it **is** observed that male ego usually prefer to marry *attiai* who are younger to them and female ego do prefer to marry *machan* **who** are elder to them

In the first descending generation, the **categorisation** of relatives **is** based fundamentally on the same lines as was noted in the first ascending generation. **Thus**, the structural principles of cross / parallel distinction and sex distinction operates together giving two male and female km terms. A **clear-cut** distinction is maintained between

cross and parallel relatives But unlike in first ascending generation, in the first descending generation, the criterion of relative age does not operate so as to give terminological distinction either among the parallel relatives or among the cross relatives

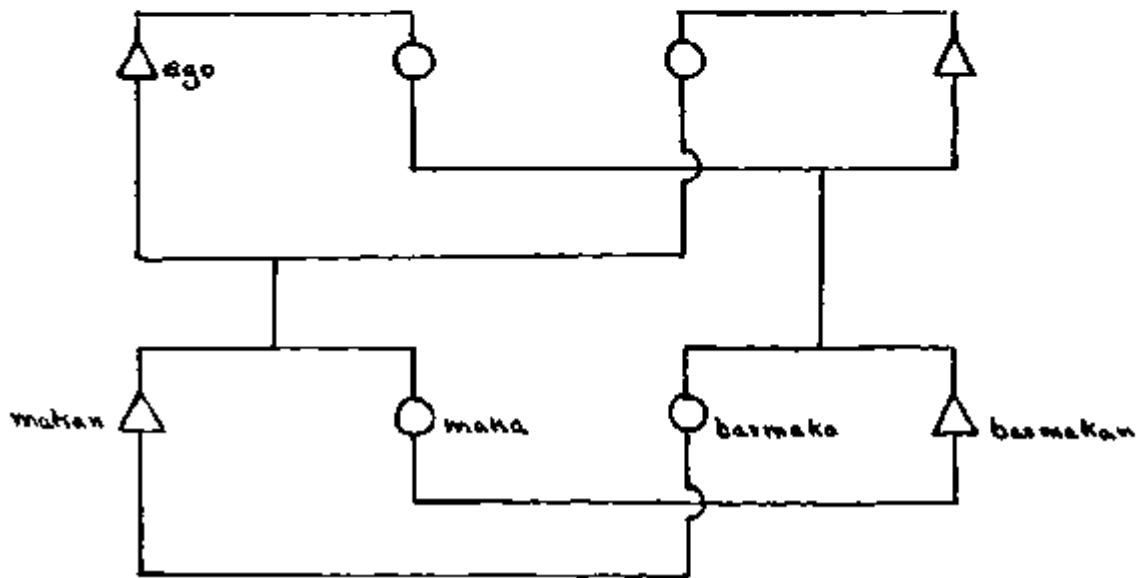

Fig 5 5 Marriageability between members of first descending generation

One's own children and same-sex sibling's children are categorised alike, but are differentiated from the children of opposite-sex siblings opposing each other and implying marriageability as shown in the fig 5 5. The parallel male kin term *makan* refers to son brother's son (m.sp) sister's son (f.sp), wife's sister's son. husband's brother's son and equivalents to them The kin term *maka* refers to daughter, brother's daughter (m.sp).

sister's daughter (f sp), wife's sister's daughter, husband's brother's daughter and their equivalents. The cross male kin term *barniakan* refers to sister's son (m.sp), brother's son (fsp), wife's brother's son, husband's sister's son, daughter's husband and their equivalents. The cross female kin term *barmaka* refers to sister's daughter (m.sp), brother's daughter (f sp), wife's brother's daughter, husband's sister's daughter, son's wife and their equivalents.

In the first descending generation, it is seen that one's own children and same-sex sibling's children are grouped under parallel relatives and opposite-sex sibling's children are categorized as cross relatives. This categorization clearly depicts the practice of bilateral cross-cousin marriage, wherein one's own and same-sex sibling's children become legitimate and potential spouses to the children of opposite-sex siblings. These categorizations can be represented in the following equations :

$$\text{Makan } S = BS (m \text{ sp}) = WZS = ZS (f \text{ sp}) = HBS$$

$$\text{Maka } D = BD (m \text{ sp}) = WZD = ZD (m \text{ sp}) = HBD$$

$$\text{barmakan } BS (f \text{ sp}) = ZS (m \text{ sp}) = DH$$

$$\text{barmaka } BD (f \text{ sp}) = ZD (m \text{ sp}) = SW$$

The characteristic bifurcation of the relatives into parallel (consanguines) and cross (affines), which is prominent in ego's generation and first ascending and first descending generation is confined only to these three generations. Beyond these levels, i.e., in the second ascending and second descending generation, the terminological distinction of cross/parallel categories is ignored. In the Dravidian system, Dumont says, 'the two kinds of relatives who are distinguished in the middle region of the vocabulary are merged at the two ends so that there is only one kind of grand-parents and one kind of grand-children' (1983: 181). Though, mentions have been made about the existence of this terminological distinction among some of the South Indian Castes (Beck 1972, Good 1980, Trautmann 1981, Reddy 1984), Mudugas make no terminological distinction between the father's father and mother's father and also between father's mother and mother's mother.

Thus among the Mudugas, *acchan* is the term used for father's father and mother's father, and *acchi* is the term used for father's mother and mother's mother. Similar!} in the second descending generation, ego's son's daughter is equated with

daughter's daughter as *perathi* and son's son is equated with daughter's son as *peran*. Among the Mudugas, from the third ascending generation, all male relatives of ego is termed as *pattern* and all female relatives *aspatti*. But in the third descending generation, the same term as applicable for second descending generation relatives are used.

The merging of kin categories at the level of second ascending and second descending generations as against to the maintenance of dichotomy of the universe of kin categories in ego's generation and first ascending and first descending generation does not hold strong to prove that cross/parallel distinction gets neutralized in these generations. Though there is no apparent terminological distinction of crossness in these generations, it is to be understood that the crossness of these relatives is maintained as far as the actual behavioural pattern is taken into consideration. Moreover, in reality, it is not possible to maintain the cross/parallel distinction terminologically beyond the second ascending and second descending generation, since the distinction extends infinitely and limitless. According to Reddy, all the distinctions of kinship in one's own and adjacent generations are not applied to distant kin such as those of the second ascending and second descending generations since, "it is a feature of the inherent need for economy in the total number of kin terms used in any society" (1984: 85).

If we analyse the structure of Muduga kinship terminology depicting bilateral cross-cousin marriage, we can see that though there is no terminological distinction in second ascending generation, the structure shows separate sets of grand-parents. This reveals that paternal grand-parents of ego are ego's wife's maternal grand-parents and ego's maternal grand-parents are equated to ego's wife's paternal grand-parents.

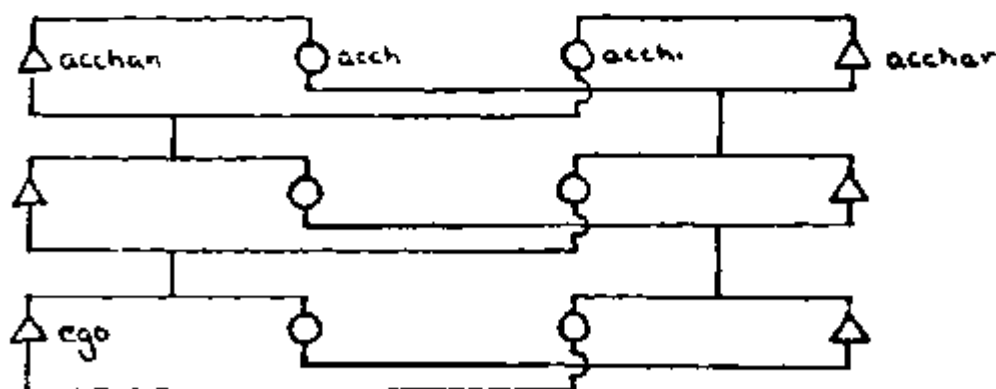

Fig 5.6 Marriageability between second ascending generation

Though in the second ascending generation, similar kin terms are used equaling FF with MF and also FM with MM, the terminological equivalence works in such a way that FF = MMB and MM = FFZ. This shows a clear cut implication of a bilateral cross-cousin marriage between ego's father and mother in the first ascending generation which is an after effect of crossness between opposite-sex siblings in the second ascending generation.

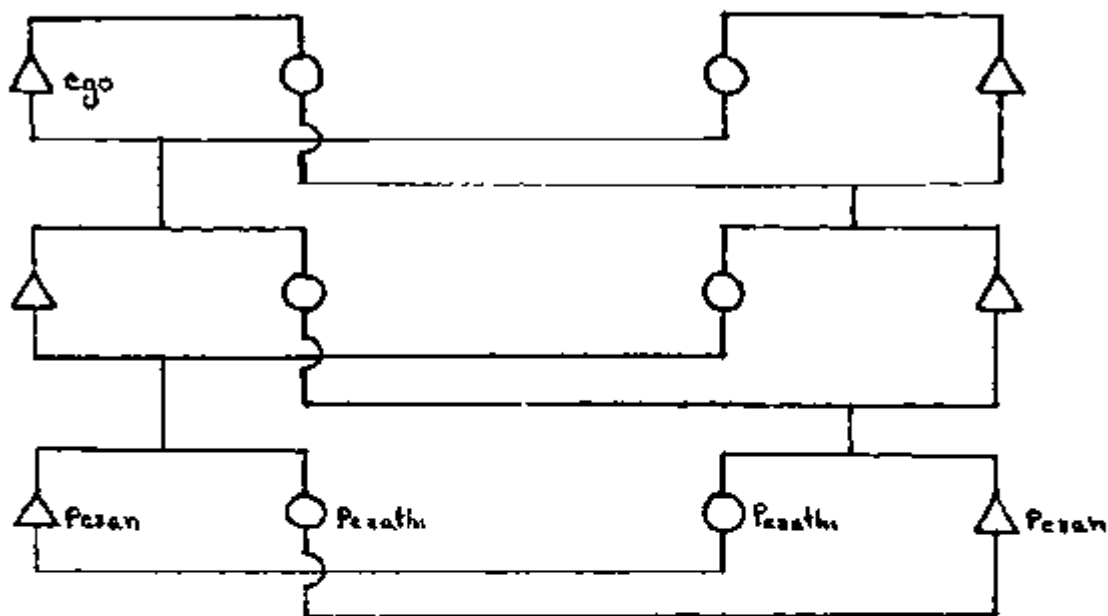

Fig 5 7 Marriageability between members of second descending generation

The same logic could be applicable for **ego's** second descending generation **where** a distinction between parallel relative and cross-relative can be derived. **Thus**, ego's son's children are equivalent to parallel **relatives**, **where** as the daughter's children are considered **cross-relatives**. The latter set of **relatives** are potential **affines** to the former set

of relatives This goes will with the rule of bilateral cross-cousin marriage The distinction of relatives in second descending generation into two sets of parallel and cross relatives can be shown in the following equation

$$SS = DDH ; SD = DSW$$

$$DS = SDH , DD = SSW$$

Apart from denying the cross/parallel opposition in the second ascending and second descending generation, Dumont (1983) goes to the extent of denying the same in the first descending generation arguing that the lack of strong lexical distinction between kin terms is a sign of weak cross/parallel distinction⁴ Though Dumont expects to find a mirror image of the father's generation in the son's generation, he says that, "both the alliance and the sex distinctions cease to be radical and are marked only by affixes, there is only one (fundamental) category Only on a secondary level can we follow up the distinctions (1983 15)⁵ Since sons and opposite-sex sibling's son share the same root and distinguished only by means of prefix, he assumes the cross/parallel distinction as less fundamental stating that "secondary differences within a class obtained by affixation are irrelevant in so far as they do not alter its unity" (1983 15) It seems that Dumont tries to equate the usage of prefix in the son's generation with the one used in parent's generation Regarding this, Scheffler rightly argues that "if it is to be maintained that the consanguine/affine distinction at the G+1 level is fundamental, it must be maintained also that there is a consanguine/affine distinction at the G-1 level and that distinction must be 'primary' rather than only 'secondary' and made by means of a prefix" (1984 568) According to Dumont, the prefix 'maru' which distinguishes nephew from son 'signifies marriage' and hence he says that, 'maga' and 'marumaga' form a single category (1983 10) However, it is to be mentioned here that, the prefix do not actually signifies marriage, but it signifies the crossness which implies marriageability Moreover, the existence of different reciprocal terms for *barmakan* compared to *makan* clearly shows the fundamental distinction between these terms rather than their unity

Unlike the cross parallel distinction, which is apparent terminologically only within the three medial generations, the distinction of sex are very well mirrored in the Muduga kinship terminolog which completel bifurcates the semantic field. Thus, a

term ending in '-i' will connote a female member (except the term *akka* in ego's generation and terms in first descending generation). While the same term ending in '-n' connotes a male member (except the term *thampi*) This similarity of suffix differentiating sex is a general feature of Dravidian terminology.

It should be mentioned here that the dimensions of crossness and sex operates together depicting the categorical distinction of cross and parallel relatives throughout the kinship paradigm. Such that, the crossness of kinsmen in a particular generation is not independent of itself, but is a derivative and dependent on both the aspects of crossness and relative sex of their linking kinsmen in the adjacent generations. Thus in the first descending generation, the children of same-sex parallel cousins are parallel cousins to one another, whereas children of same-sex cross-cousins are cross-cousins to one another. Children of opposite sex parallel cousins are cross-cousins to one another and children of opposite-sex cross-cousins are parallel cousins to one another.

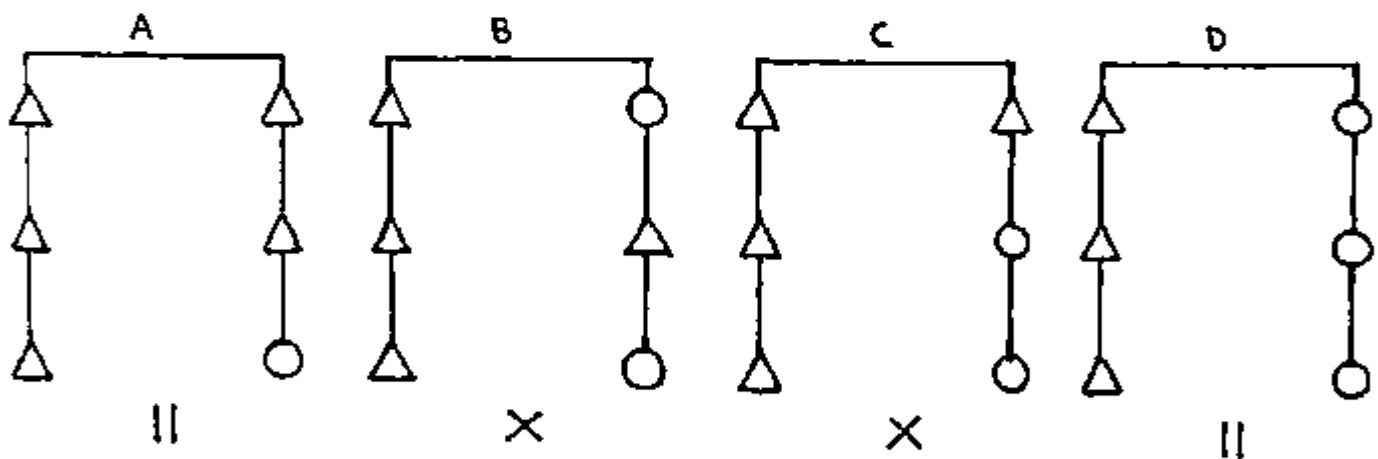

Fig 5 8 Distinction of cross and parallel rela

Moreover, these two principles of distinction operates together such that all kin terms are structurally opposed to each other. In the first ascending generation, there are two such opposition. The kin term representing 'father' category is opposed to the kin term representing the 'mother's brother' category. Similarly, the kin term denoting 'father's sister' is opposed to the kin term denoting 'mother'. In ego's generation also there exist two structural opposition of kin terms. *Anna/thampi* category is opposed to *machan* category and *akka/thanke* category is opposed to *attiai* category. In the first descending generation there is the opposition of *barmakan* category and *maka* category. Since there are only two terms in the second ascending and second descending generation showing the gender distinction, the cross/parallel opposition is neutralized in the terminology.

Based on the above principle of opposition, the Muduga kinship terminology can be described as bifurcate merging system which is a characteristic feature of Dravidian terminology, where the terminological system emphasizes ego's descent by (1) equating father and his brothers (APPAN) but separating off mother's brothers (MAMAN) (2) equating mother and her sisters (AUVEI) but separating off father's sisters (MAMI). This bifurcate merging is also evident in ego's generation where the terminology specifically separates out cross-cousins who can be married (FZD, MBD-attiai) from the sisters (eZ, yZ, FBD e/y, MZD e/y)-akka/thanke) whom one cannot marry. Similarly, male cross-cousins (MBS, FZS-machan) are separated from brothers (eB, yB, FBS e/y, MZS e/y)-annan/thampi). By equating ego's sisters with FBD and brothers with ego's FBS, the descent group unity is also emphasised.

The Muduga kinship terminological sets are very much symmetrical such that a reduction of terms into reciprocal sets is possible. The principle of reciprocal set operates in such a way that the kin terms stand in fixed structural relationships to one another. This relationship exist independently of their various genealogical denotata. According to Leach, "a kinship term in isolation has no significance; it is the relationship expressed by a pair of reciprocal terms which has structural importance and which can be interpreted in terms of behaviour" (Leach 1961: 34-35). All the four structural principles such as the distinction of generation, crossness, sex, and relative age operate in the existence of this reciprocal set.

In the first ascending and first descending generation, there are two reciprocal sets. Out of this the first one is *appan; auvan / makan, maka*. Though the **FeB** and **FyB** are distinguished from one another by the use of prefixes like *ballia* and *sinna* to the term *appan*, there are no distinct reciprocals of these three terms. There are instead the common reciprocals *makan, maka* implying the fundamental unity of **F**, **FeB** and **FyB**. Similarly, despite the differentiation of **MeZ**, **MyZ** from **M** by the use of prefixes to the term *auvai*, there are no separate reciprocals for each term but, the common reciprocals *makan, maka*.

The second set of reciprocals in the first ascending generation and first descending generation is *maman, mamı / bannakan, barmaka*. The senior members of this set are the parents opposite-sex siblings (**MB**, **FZ**), treated as spouses to one another (**MB** = **FZH**, **FZ** = **MBW**). Their reciprocals are a person's opposite-sex sibling's children and children's spouses. Here, the reciprocal sets are based on the structural principles of cross/parallel distinction, generation and sex.

In ego's generation, there are two reciprocal sets. The first set is *annan, akka / thampi, thanke* dealing with siblings and parallel cousins. The reciprocal set includes siblings and parent's same-sex sibling's children who are parallel relatives and are unmarriageable. The structural principles of cross/parallel distinction, age and sex operate in this reciprocal set. The second set of reciprocals in this generation is the cross-cousins. This includes parent's opposite-sex sibling's children (**MBD**, **FZD**, **MBS**, **FZS**) who are falling in the marriageable category. Thus, here we have the reciprocal set *machan, attıai / machan, attıai*. It is to be mentioned here that among the **Mudugas**, in ego's generation for cross relatives, there is no distinction of age relative to ego which gives rise to the possibility of self reciprocals. Thus the terms *machan* and *attıai* are self reciprocals when applied to same-sex cross-cousins. Apart from this reciprocals, there exist another reciprocal set in ego's generation which is applied to affines who are immediately related through marriage and with whom there exist a **coverture** relationship. This reciprocal set is *konthan/konthı*. *Konthan* includes **HeB** and **yZH** for a female ego, and *konthı* includes **WeZ** and **yBW** for a male ego. The structural principles which operate in this reciprocal set are distinction of crossness, sex and relative age. Apart from these, there exist in ego's generation another reciprocal set which is applied to

one's spouse This reciprocal set is *alan* (husband) / *pentu* (wife), and the structural principle of distinction of crossness and sex operate in this reciprocal set-

In the grand parental and grand children's generation, there is only one reciprocal set, *acchan* , *acchi* / *peran*, *pcraihi*. The senior members of this set includes parent's parents and their siblings (FF, MF and **FM**, MM) Reciprocally there is children's children who includes SS, DS and **SD**, DD. The structural principles of the distinction of generation and sex operates **in this** reciprocal set

Table 5 2 Muduga kinship terms in reciprocal sets

Km terms and genealogical denotata

- 1 *acchan* (FF,MF) + *acchi* (FM, MM)

peran (SS, DS) + *perathi* (SD,DD)
- 2 (ballia-,sinna-,) *appan* (F,FB) + (ballia-, sinna-,) *auvai* (M,MZ)

makan (S,BSms, ZSfs) + *maka* (D,BDms, ZDfs)
- 3 *maman* (MB,FZH) + *mami* (FZ, MBW)

barmakan (ZSms, BSfs) + *barmaka* (ZDms, BDfs)
- 4 *annan* (eB) + *akka* (eZ)

thampi (yB) + *thanke* (yZ)
- 5 *machan* (MBS,FZS) + *attiai* (MBD,FZD)

machan (MBS,FZS) + *attiai* (MBD,FZD)
- 6 *Konthan*(HeB, yZH(fs))

Konthi (WeZ, yBW) (m s)
- 7 *alan* (H)

pentu (W)

The relationship terminology is not restricted to the immediate **kin** circle or close **relatives** of an ego linked through either consanguinity or **affinity**. They are extended to

the entire universe of ego's relatives as far as he can identify and recognise. Even one recognises many kinsmen and encounters them fairly often. The nature of extension of kin terms from the circle of primary and immediately connected kin of ego is based on two fundamental principles. The first one is basically dependant on descent and the affiliation to the patrilineal descent group. All the members of one's descent group are believed to be biologically linked and are considered as consanguines, who are classified or grouped under one kin categories. The second rule of extension depends on the symmetric alliance made through the bilateral cross-cousin marriage which has aptly been characterized by Dumont (1953) as "affine's affine as kin" for Dravidian kinship. Dumont's ideas are similar to that of Good (1980) when he suggested to consider "cross relative's cross relatives as parallel relatives". The evident inferences from this rule are parallel relative's parallel relatives are "parallel" and parallel relative's cross relatives are "cross". This rule of terminological extension shows that kin terms are not restricted to one's own kin group, but it cut across the boundaries of kin through the above mentioned principles. The former principle favours a lineal extension of consanguineal kin terms vertically and the latter favours an extension of both consanguineal and affinal kin terms laterally bifurcating the entire relatives into two categories.

It is to be mentioned here that, behind the above two fundamental principles, certain rules of merging and equation functions so as to reduce extended kin types to the focal kin types for kinship categories^{fe}. Out of these, the important rules are -

a) The same-sex sibling merging rule. Any kinsman's same-sex sibling, as linking relative is equivalent to that kinsman as linking relative. Thus, for eg, FFB = FF and MMZ = MM.

b) The opposite-sex cross-cousin - spouse equation rule. Any man's MBD or FZD will be that man's wife, any woman's MBS or FZS will be that woman's husband.

$$(ms) \text{ MBD/FZD} = (ms) \text{ W}$$

$$(fs) \text{ MBS/FZS} = (fs) \text{ H}$$

c) Sibling's spouses - sibling equation rule. The spouses of siblings are considered as siblings. Thus, for eg, WZH = B and HBW = Z.

Though the entire relatives are encompassed under the category of parallel and cross

through the principle of extension, frequent interaction and reciprocal rights and obligations take place only between immediately connected relatives constituted by close consanguines and affines. These circle of immediate relatives are the members of two affinally related families restricted to the three generation. Beyond this level there is no effective interaction. The significance of marriage alliance and obligations **and** duties are prominent and clearly evident **in this** three generation level. Beyond **this**, the wider circle of relatives consist of **extended** affines and consanguines connected through the core relatives and are treated as distant relatives.⁷ The interaction between them is not frequent and **is** weak.

Members of the three generation level of two **affinally** related families try to retain the closeness of alliance by continuing the marriage relation generation after generation. But there are possibilities of new members entering the range of **one's** own circle of immediate relatives by means of **non-kin** marriages. **Nevertheless**, these new affines and the potential cross-cousins **will** be equated together **in** the category of "brothers", and the ceremonial obligation of cross-cousins and cross-relatives remain unaltered. At Thaze-Abbannoor, **Bokken's** marriage was not **with his** MBD. **His** mother's brother Chathan's three daughters were married to distant relatives, **Kakkilinkan**, **Ramaswami** and **Raju** respectively and all of them, including Bokken were equated together **considering** each other as 'brothers'. However, the ceremonial **right** and obligation towards Chathan remains **with his** sister's son Bokken. Thus, during the funeral of Chathan, it was Bokken who had the privilege of performing the *kattakal-pidikkal* • for **his** MB, Chathan.

Km categories can be extended **in** any direction, according to the principles inherent **in** the system. A person may trace **his** relation **with** any member of **his** community based on the rule of **categorization** such that they fall **in** the frame **work** of the km terminological paradigm. The lateral spread of the **kin** terminology through extension functions to bring the entire members of the community under definite category for an ego. However, **in** all **cases**, it is not possible for an ego to place a **person** aptly in the real terminological category. In such cases, he has to trace the genealogical **link** to that person either through **his** parents or through any of his primary **kin**. Once the correct genealogical **link** **is** established through any **of ego's** primary **kin**, it **is** reduced to definite

kin category Unless and until the relationship is traced and reduced to the focal kin type- no kin term is used to address a person who is new to ego.

The process of tracing of kin terminology can be displaced here with the help of a case When asked about his relation to Chekidan of Mcle-Abbannoor, Kaden replied that since he had heard Chekidan addressing his father as *annan*, he should be in the category *sinnappan* (FyB) for him However, he clarified the categorical relation by tracing the genealogical link through his wife Chekidan's father's second wife's son is Nanjan of Anakkal hamlet and Kaden's wife addresses Nanjan as *maman*. Since Nanjan and Chekidan are 'siblings' and through the same sex-sibling merging rule, Chekidan is also *maman* for Kaden's wife And thus, for Kaden, his wife's *maman* should be *sinnappan* Regarding this working out of terminological usages, Good correctly writes . "If ego knows what term to use for alter A, and also knows what term A uses for alter B, he can easily work out what he himself should use for B These are 'extension rules'.. ." (1981 113)

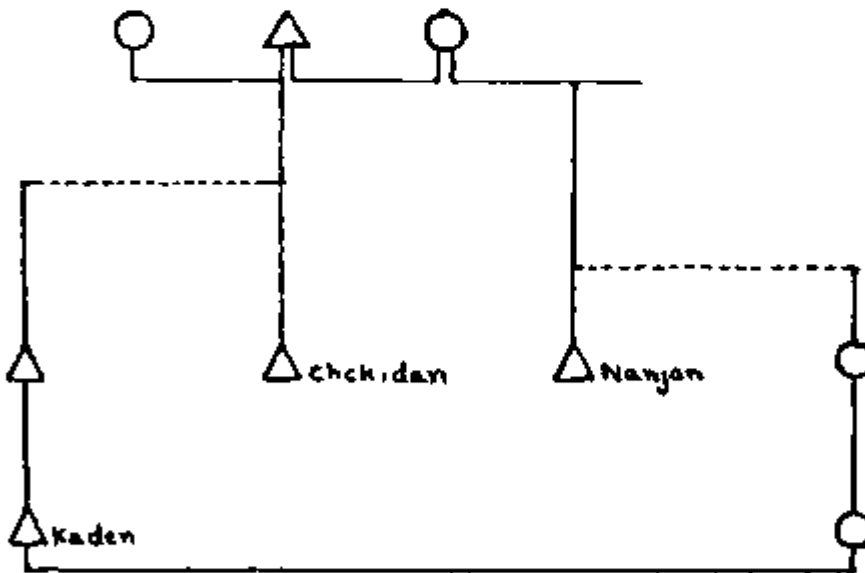

Fig 5 9 Genealogical representation of Kaden's relationship with Chekidan

In another case, when Raman from Thodukki visited Thaze-Abbannoor, he came across Panali and Rangan- Rangan was not a resident of Thaze-Abbannoor, but had come as a guest to Panali's hut. Raman was already aware of the relationship he is having to Panali. but he does not know to which kin category Rangan belongs and also the

relation between Panah and Rangan. When Raman asked Panali how Rangan is for him (i.e. the kin term he is using to address Rangan), he was unable to give an answer. Later Panali revealed that Rangan is his elder sister's son. Thus, they are in the relation *maman/barmakan*. Panah is in the category *barmakan* for Raman and since Rangan is *barmakan* for Panali, the relationship between Raman and Rangan is of the type *acchan/peran* (grand-father/grand-son).

When Raman explained the terminological relationship between Panali and Rangan, both of them laughed out of surprise. Since they were residing in different hamlets they were not used with the km terminological addressing. Moreover, since they were children and of the same age group, it was difficult for them to conceive that they were related as *maman / barmakan*.

In certain cases, even elders also find it difficult to use proper kin term and will be confused as how to address a distant km with whom he is not having frequent interaction. While talking to Kaden's wife of Mele-Abbannoor, Nanjappan was confused over the kin category to which she actually belonged and finding it difficult to address, he said "*eccheolakya teriya*" (don't know how to address). Thus Kaden's wife herself had to reveal that she is in the *murai simnawwai* (MyZ) for Nanjappan. She is actually Nanjappan's mother's brother's son's mother-in-law.

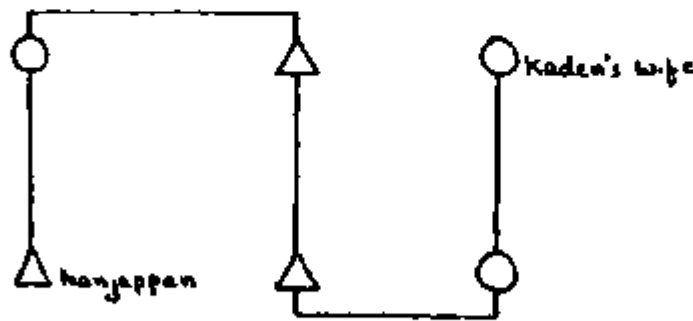

Fig 5 10 Genealogical representation of Nanjappan's relationship with Kaden's wife

In yet another case, few children were playing together. Out of them, Neeli's daughter Sindu found it difficult to address her mother's brother's (Panali) wife's brother, who is of her same age group and had come from another hamlet as a guest. But later she addressed him by the kin term '*maman*' which was not correct. But when this incident came to Sindu's mother's elder brother Vella's notice, he scolded her saying.

"*makkakku oru neppillatha olakkalu. !!*" ("children are having no sense of addressing !!") He then asked her. "*panalt ninakku ecchepe*" (How is Panah for you ?) She replied "*maman*"

Vella: "*maman pentu mnakku ecche pe?*" (How **is *maman*** 's wife for you ?). She replied that she should be *mami* for her.

Vella then asked "*appu, mamithu thampu vannu mnakku ecche*" (if so, how is "*mami* 's brother for you ?)

To this question she could not reply and Vella himself had to answer that he is *sinnappan* (FyB) for her and not *maman* (MB)

Though most children are aware of the **kin** term to be used to address their relatives of senior generation, the confusion regarding the proper use of the **kin** terms occur among children of same age group, especially if they are of different generation Children always use personal names rather than **kin** terms to address their age mates Only when they grow up, they start using appropriate **kin** terms to address their relatives of same age group and same generation

The rules of prescriptive bilateral cross-cousin **marriage** practiced by the Mudugas are well depicted in their **kin** terminological system itself The two major rules inherent in the marriage system are the prohibition of marriage between lineal descendants and prohibition of marriage between members of different generations The relationship between every category in the terminology **carries** the implication of consistent and regular cross-cousin marriage The **idea** of cross-cousin marriage **is embedded** in the terminology and **cross-cousin** marriage **is** imperative **if** the kinship terms are to be kept consistent The **classificatory** kinship terminology functions in such a **way that** not only genealogical **affines**, but distant relatives may also be brought under the **wide** compass of 'marriageable category' **Yalman** emphasize **this** when he writes "**it is** the systematic linguistic categories of kinship (the terms of reference) **which** structure the **entire kin** circle and specify in an orderly manner marriageable and **unmarriageable** persons in that universe What **we call cross-cousin** marriage **is** simply a restatement of the rights and obligations inherent in certain categories There **is** no lineal emphasis at all, but only rules regarding the interconnections between categories .. ." (1967 : 357).

Among the Mudugas, the classification of entire relativeness into definite terminological category plays a crucial role in marriage. Such that **the** recognition of these categorical rule establishes marriage alliance. **It** is important to understand that the aspects of Muduga marriages are not explicitly associated with the notion of descent, but **with** categorical rules. The emphasis on lineal exogamy and the corollary distinction of marriageable groups and unmarriageable groups do not form a primary and important rule in Muduga marriage procedure. Thus, the people often say “*murai irunthal emma kalyanam mudikkuve*”, which means, **if** there exist a marriageable relation (1 e., **if** they are **in** marriageable category) they go for alliance. **This** shows the preference attached to kin categorical rule rather than to an apparent rule of lineal exogamy **with** regard to **marriage**

However, **this is** not to conclude that the notion of descent **is** not a major rule and does not have any **function** in Muduga marriage. But **it is** to emphasize here that the rule of lineal exogamy and the concomitant rule which **prescribes** alliance **with** marriageable descent groups **is** crucial, which **is** embedded **in** kinship terminology itself. Thus, the marriage between children of same-sex cross-cousins and prohibition between children of opposite-sex cross-cousins shows the implicit expression of **this unilineal** reckoning. **This** nature of Muduga marriage emphasizing category rather than lineal aspects also explains to an extent the occurrence of alliance relationship between Mudugas and the neighboring group, kurumbas

Terms of address :

On analyzing the pattern of address among the Mudugas, **it is** seen that, the relatives of senior generation as well as those who are of the same generation but elder to ego are addressed by **kin** terms, and the terms of address and reference coincide well. Separate terms and also names are usually used to address members **younger** than ego. Since names are used **in** addressing these **kinsmen**, the **kin** terms occur only **in** referential situations. No terms are used to address members **who** are **in** the category of avoidance relationship.

Among the Mudugas, a general feature of addressing each other especially among elders **is** according to **his** or her relationship **with** the child. **Thus**, tecknonymy **is** an **important** aspect of addressing among the Mudugas **which** are universally employed

when a person has a child A person will be called by his name until he marries and after he has a child, people begin addressing and referring to him as "father of so and so" employing his first child's name Similarly his wife will also be addressed as "mother of so and so" Thus, for eg, at Thaze-Abbannoor, **Velli**, whose eldest child is Kurumban will be addressed as Kurumbanappan (father of **Kurumban**). Similarly **Velli's wife Jakki** will be addressed as **kurumbanauvai** It is to some extent unusual and degrading to use a person's childhood (personal) name instead of his tecknonymous **name**, for it imply that he is still immature Thus, all married person (who are 'father' and 'mother') younger to ego, are usually addressed by tecknonymous names, and relatives who are elder to ego are addressed by the respective km terms (see Table 5.3 and 5.4) **However, it is** to be mentioned that, even these tecknonymous way of addressing **is** prohibited **in** cases of avoidance relationship In such cases, tecknonymy **functions** only as a reference term

Table 5.3 Terms of address for a male ego

Male relatives		Female relatives	
Genealogical denotata	Terms of address	Genealogical denotata	Terms of address
FF, MF	acchan	FM, MM	acchi
FeB, MeZH	balliappan	MeZ, FeBW	balliauvai
F	appan	M	auvai
Fyb, MyZH	sinnappan	MyZ, FyBW	sinnauvai
MB, FZH	maman	FZ, MBW	mami
WF	-	WM	-
eB	annan	eZ	akka
yB	(name), ponna	yZ	(name), ponni
MBS, FZS, ZH, WB	machan, (tecknonymy)	MBD, FZD, eBW, WyZ	attiai (tecknonymy)
yZH	machan, ponnialan	yBW, WeZ	-
S, BS	(name), ponnan, ayyan	D, BD	(name), ponni, amme
ZS	(name), (tecknonymy)	ZD	(name), (tecknonymy)
DH	-	SW	-
SS, DS	ayyan	SD, DD	amme
		W	ole, (tecknonymy)

Table 5 4 Terms of address for a female ego

Male relatives		Female relatives	
Genealogical denotata	Terms of address	Gynealogical denotata	Terms of address
FF, MF	acchan	FM,MM	acchi
FeB, MeZH	balliappan	MeZ,FeBW	balliauvai
F	appan	M	auvai
Fyb, MyZH	sinnappan	MyZ, FyBW	sinnauvai
MB, FZH	maman	FZ, MBW	mami
HF	-	HM	mami
eB	annan	eZ	akka
yB	(name), ponnann	yZ	(name),ponni
MBS, FZS,ZH,HyB	machan, (tecknonymy)	MBD,FZD,BW,HZ	attiai (tecknonymy)
yZH,HeB	-	yBW	ayyan pentu,attiai
S,ZS	(name),ponnan,ayyan	D,ZD	(name),ponni,amme
BS	(name),tecknonymy)	BD	(name),(tecknonymy)
DH	-	SW	ayyan pentu
SS,DS	ayyan	SD,DD	amme
H	one,(tecknonymy)		

Moreover, these nature of addressing and referring makes the people more easier to distinguish between persons who are having similar names At Thaze-Abbannoor, there are three persons named as **Kali** But they are addressed and referred by different tecknonymous terms The first **Kali, s/o Veeran** is referred as **Murugiappan**, and **Kali, s/o Ooshi** is referred as **Rajendranappan** and yet another **Kali, s/o Velli** is referred as **Valhappan**

A person will be known after the name of his or her first child throughout life even if the child dies Moreover, a man and a woman who are already having children in their first marriage, if enters in a second marriage and begets children, will not be known by the name of the child bom to the new union, but by their first child bom to their first union At Thaze-Abbannoor, Kakkilinkan, after the death of his first wife, has married Vellachi who was earlier married to Bokken of Thaze-Abbannoor. Though in this union they are having a child, they are addressed and referred by different names. Thus, Kakkilinkan is addressed as Kadeappan since Kade is the first child bom for him in the

first union and Vellachi is addressed as Somanamai since Soman is her first child in her first union

If in case, a couple is not having children, they will be addressed or referred by the name of their spouse. Thus, for eg., Kullan, whose wife is Maruthi will be referred as Maruthialan (husband of Maruthi) and Maruthi will be referred as **Kullanpentu** (wife of Kullan)

Parents and elder siblings address their male child/younger male **siblings** as *ponnan* or even *ayyan* and their female **child/younger** female sibling as *ponnt* or *amme*. However, *amme* is also used to address very young female child and *ayyan* is also used for very young male child

A male ego addresses **his** younger sister's husband and daughter's husband as *ponmalan*. But he will not use any term as such to address **his** son's **wife** or younger brother's **wife** since there exist avoidance relation between them. Similarly, a female ego addresses her son's **wife** and sometimes her youngest brother's **wife** as '*ayyanpendu*'. But she will not use any term to address her **daughter's** husband or younger sister's husband since there exist avoidance relation between them

A male ego addresses/refers **his** elder sister's husband as *machan* and elder brother's **wife** as *attai*. A female ego **addresses/refers** her elder brother's **wife** as *attai* and elder sister's husband as *machan*

A husband and a **wife** addresses each other and refers using their eldest child's name (tecknonymous term). But if they are having no children or they are **newly married**, a **wife** will be addressed by the term '*ole*' and referred to as '*ennupentu*' (my **wife**). Like wise, a husband will be addressed by the word '*one*' and will be referred to as "*ennu alan*" (my husband). However, it is to be mentioned here that **these** terms '*ole*' and '*one*' which are usually used by husband and **wife** to address each other, do not **carry respect** and are also used casually to address members of same age group **who** are considered as equals and also younger members.

It is evident that people do not use km terms **always** for addressing. Except for persons of senior **generation**, for members of ones own **generation**, tecknonymous terms are adopted and younger members are addressed by names and non **kin** terms.

Among the Mudugas, there are certain terminological usages which refer to more than one person collectively. The nature of the usage is that it refers to the number of persons and depicts the kind of similar relation existing between them. Thus, two male siblings will be referred to as "*thampi rantu*". Here, the **kin** term *thampi* shows the 'brother' relation and the affix 'rantu' denotes the number of persons. Similarly, when they say "*thammuthanke moonnu*" means "they, three sisters". These usages are restricted to relatives of the same generations. Moreover, it is to be understood that with regard to cross-cousins, the reference will be restricted to two members only, since in a group of more than two persons there cannot be only 'cross-cousin' category alone but also 'brothers' according to the rule of Dravidian kinship, "affine's affines are kin". Thus, for cross-cousins, the terminological usage will be "*thammu machan rantu*" (they both *machan*) or "*thammu attai rantu*" etc., and the affix *moonnu* (three), *naalu* (four) etc. will not be attached to these terms as used along with parallel terms *thampi* and *thanke*.

Another feature observed in the Muduga kin terminology are the usages made for referring the immediate relatives of a third person. In Muduga terminological usage, to refer a third person's immediate male relative (irrespective of cross/parallel distinction), they usually use the affix '*acchan*' after the particular **kin** term, and similarly to refer a third person's immediate female relative, the affix '*acchi*' will be added after the kin term. Thus, for eg., Kaden and **Kali** while talking, refers **Kakki's** father as *Kakkithu appanachan* and **Kakki's** mother as *Kakthu aivai acchi*. Similarly, the usages *maman achan*, *mamiacchi*, *akkanachi* etc. Here through this usage ego is depicting the same **kin** term as used by the third person to address the particular relative. Usually, this third person's relative will not be a close relative and this type of usages are made particularly for referring and emphasizing the closest genealogical denotata of the term.

Also noted, as aspect of addressing, are certain usages of affix terms attached to the main words while talking to or addressing a person, which refers to the nature of relationship between ego and the person addressed. Such that, certain affixes used for persons of senior generation imply respect and certain other affixes carry no respect as such, and are used for relatives of same generation who are considered equal and also to younger members. Thus, while talking to a male relative of ego's own generation who are younger to ego and also members of younger generation, ego uses the affix '-na' to the

main word This usage carries no respect to the addressee. For eg., usages like... "*kette-na*"? (" . you heard?") or "*banthe-na.. .?*" ("___you came.?"") are put towards members who are younger to ego. Similarly, an ego uses the affix *-pe'* while addressing a female relative who **is** younger to ego. For eg , "*bande pe'* (___you came.?"").

The affix *'ra'* and *-ga'* **is** added to the ending word **while** addressing both male and female relatives of senior generation, and persons whom ego respects, eg , "*kande-ra*"(" did you see?"") or "*thinthe-ga*?" (" .did you eat?"")

The affix term *'me'* **is** used while addressing a male relative whom ego treats as equal or members younger to ego Similarly, the term *'pe'* **is** used while addressing a female relative whom ego treats as equal or younger to ego It **is** to be mentioned here that among the Mudugas, husband and **wife** usually use these informal term *'pe'* and *'me'* to address each other which shows that they consider each other as equals

Super categories and sub-classes .

Among the Mudugas, all members are treated as relatives according to the **kin** categorical extension, and all relatives **with** whom one can trace relation come under the compass of a single large category known as *Chonthakarar* These all embracing class of relatives, '*chonthakarar* **is** divided **into** two classes'⁹ The former **is** labeled by the people as *anna-thampi* category (1 e , parallel relatives) **with** whom marriages are prohibited and the latter **is** termed as *macha-maman* category (1 e , cross **relatives**) **with** whom marriages are permitted The compound terms *anna-thampi* and *macha-maman* not only shows the distinction between male parallel and **cross-kin** of the three medial **generations**, but **it** indicates **in** a broader sense the opposition or the dichotomy of the entire relatives of the community **into** two sections,¹⁰ each consisting of both genealogically related close kin and distantly related members through the rule of extension Though these aspects of the terms are questioned by **anthropologists**, among the Mudugas, the label *anna-thampt* **is** used **in** reference both to **kin** categories defined by members **in** descent groups (**i e.**, agnates) and **is** also an inclusive term refering to all non-mamageable relatives **in** the community¹¹ Thus the people use the term *njeringina --chonthakarar* to refer genealogically related close kin and *akanna-chonthakarar* to refer distantly related **kin** both parallel and cross. **Thus**, these **two** sub categories of *chonthakarar* consist of both

parallel and cross relatives. When the term *kudumbakarar* is used to further distinguish parallel relatives of the category *njermgina-chonthakarar*, there is no separate term for cross relatives in this category, and cross-relatives of both these categories are referred together as *macha-maman*.

CHONTHAKARAR		
njennngma- chonthakarar	Anna-thampi	Macha-maman
	kudumbakarar	macha-maman
akanna- chonthakarar	anna-thampi	macha-manan

Fig 5 11 Structure of Muduga kinship categories

Moreover, Rudner has gone to the extent to suspect the existence of the compound term referring cross categories when he writes, “**Maman-machan** seems entirely an anthropological fabrication for naming a kin super-category. Without it, we would be left only with the English words ‘cross’ or ‘affinal’” (1990: 164). However, it is to be strongly emphasized here that, these terms are not anthropologist's labeling for cross and parallel relatives, and other than Mudugas, mentions have been already made of other Tamil groups practicing similar native labeling for these categories (see Kapadia 1995).¹²

The two classes representing parallel relatives and cross relatives are further divided into definite kin categories by the underlying principles of generation, sex, age and crossness. In the parent's generation, it is seen that these classes are still divided into sub-classes through the addition of affixes. Thus, in the first ascending generation, among

the male parallel relatives, the '*appan*' class is divided into a lineal and non lineal class. The designation of the former is *appan* and the latter has no designation of its own but is divided into two sub classes designated *balliappan* and *smnappan*. According to Dumont (1983 10,14-15), the secondary terms formed by affixes are not essential for the understanding of Dravidian kinship system and that these secondary terms designate sub classes of a higher-order and logically prior superclass.¹³ But Scheffler goes against Dumont's view and argues that superclass is not logically prior to sub-classes and that one of those sub-classes is the focal class on which the super-class as whole is predicated (1984) 565-67) For Dumont (1983), the basic meaning of '**Appa**' class is '**male consanguines of parent's generation**' and the expression of **this** broader class is extended to the expression of sub-classes For **Scheffler (1984)**, the central sense of the expression 'appa' is 'father of or 'male parent of and that the expression is extended to a broader range of km and relatives by marriage, and thereby arguing in favour of polysemy by 'sense generalization' ¹⁴Rejecting scheffler, Good (1985' 546) agrees with Dumont and suggest that the sub-classes are derived from the broadest and logically prior super-class, and argues for polysemy by sense specification

According to the kin terminological usage existing among the Mudugas, it is noted that there is a super class, '**Appan**' (which is divided into sub-classes), the basic meaning of which is '**male consanguines of parents generation**' **This is** very well evident when they often say "*athu vannu enakku appan akadom*" (that should be '*appan*' for me'), which means that the other is in the category '*appan*' for ego Here they are referring to '**Appan**' super class And, when they use the term '*pirathina appan*', it refers to one's male genitor whereby they are referring to appan sub-class

In the first ascending generation, there occurs certain genealogically identified terms like *thaimaman* (real MB) and *thaimami* (real FZ) Each of these terms denote a single genealogical referent in the kin structure and hence a single meaning unlike other terms which are categorical identities that denote several genealogical position in the kin structure

By extending the same logic of **sub-class** distinction among parallel category to the **cross-category**, **scheffler (1984)** argues that '**tai-maman** constitutes phonetically and semantically a linguistically **marked sub-class** of the super class '**MAAMA**'. However, in

the context of reciprocal sets, it is clearly evident that, for the males, the possible reciprocals of 'makan' are *appan*, *baliappan* and *sinnuppan*¹⁵. Where as *maman* is the only reciprocal of *barmakan* and not *thaimaman*, which shows that the distinction of subclass is prevalent only among the parallel **kin** of parents generation and not among the cross. It is to be mentioned here that the distinction observed among both parallel and cross relatives are not based on the same criteria or principle. While the principle of relative age operates in the former category, the criteria of genealogical closeness operates in the latter which is not a structural principle upon which the division of semantic space in Dravidian terminology is based.¹⁶ However, from the behavioural context, one cannot rule out the importance attached to this distinction based on the criteria of genealogical closeness among the cross **kin**.

Analysis of the kinship terminology clearly shows that Mudugas make a fundamental distinction between **consanguineal** (parallel) and **affinal(cross)** relatives. The kinship behaviour follows the same pattern. The interpersonal interaction among the consanguineal relatives are framed on the basis of **patrilineal** principles and descent organisation of the Mudugas. And it is through the marriage alliance between descent groups that the members establishes and extends their affinal **link**.

Following is the description of the interpersonal behaviour that **characterises** some of the crucial consanguineal and affinal relationships, where relationships between different **kin** categories involve distinct pattern of social behaviour, of rights and obligations.

Kinship behaviour

Father (appan)-son (makan) relationship The relationship of a son with the father is characterised by respect and distance, and the behaviour of father towards his son is more of authority. A son addresses his father by the term *appan* and the reciprocal is *makan*. But usually a father address his son by name or other terms like '*ayyan*' or '*ponnan*'. The **father-son** relationship is seen in terms of descent based on well defined rights and obligations. A child will be given the name from among those of his father's group. Boys learn from their father how to clear the **field, hunt**, fish and engage in other activities of a man. A son will be dependent on his father until **marriage** after which he

sets up his own independent household. In certain cases, even after marriage, he lives with his father's family till he erects his new hut and it is often the major obligation of the father to erect a new hut for his married son.

A son helps and assists his father in all economic activities from his early age itself and on reaching adolescence, he takes up most of the activities done by his father such as clearing the field, hunting, collecting fire-wood etc. After getting married and establishing his independent household, the relationship between son and father becomes more of formalized nature and they rarely get together. Thus, their frequent contacts and the dependency of a son on his father become reduced. **Nevertheless**, he remains and resides nearby his father's hut and supports and extends help whenever he is in need. Sharing of food and labour continues between the households of father and son.

The strong agnatic bond and the attendant rights and obligations are very well depicted in the father-son relationship. A case in support of this is the relationship existing between Kakkı and his son Bokken of Thaze-Abbannoor hamlet. Quarrel between Kakkı's and Bokken's wives had caused a break in the relationship between the two families and also got reflected in the father-son relation leading them also into minor clashes. But when asked about his father, Bokken says that though Kakkı scolds him and they enter in quarrel, he respects his father and is always under his shade, and whenever he is in problem, it is his father from whom he seeks help other than any one. More over, Bokken is still staying very close to his father's hut and at times exchange night food with his father's household and also extends labour help whenever he is in need.

It is the father's obligation to make **bride-price** payment for his son and to take all responsibilities to carry out his marriage. In his old age, a father stays along with his son and it is the son's responsibility to care for his old father. In certain cases, a son may be obliged to pay the **bride-price** of his father if any balance amount is left at the time of his father's death.

Father (appan)-daughter (maka) relationship : The relationship of a daughter towards the father is of respect and distance and the father establishes authority over the **daughter**. A daughter addresses her father by the term **appan** and the reciprocal is **maka**. But usually a father addresses his daughter by name or other terms such as **amme'** when she

is very young or '*ponni*' if she is grown up. A father gets along with his daughter and care her while she is young, and after adolescence, he has little interaction with the daughter. A girl may thus move about in the company of her father till she is eight to ten years of age, after which a father very rarely involves in the affairs of his daughter. A father shows concern towards his daughter and it is his responsibility to arrange her marriage. It is the father who is having the right over the **bride-price** of his daughter. Since father enjoys the right over the daughter's **bride-price**, **it** is his obligation to reciprocate **it** by giving a cattle and few household utensils for the son-in-law or his kin. After marriage, a daughter stays along **with** her husband **in** his hamlet and hence the interaction between a daughter and a father gets reduced. **Nevertheless**, she retains her link **with** her natal household and visits her parents **in** all important festivals and ceremonial occasions. Her strong bond and obligation towards her natal group becomes clearly evident when she **is** obliged to contribute her share as *petta pillai panam*¹⁷ at the time of ceremonial **occasions** **in** her natal hamlet. Any break **in** the relation of a daughter to her husband's family due to quarrel or death of her husband forces her to return to her natal land to seek shelter **in** her father's household. Thus, even after marriage, among the Mudugas, the relation of a daughter towards her father and father's group persists.

Mother (*auvai*)-Son(*makan*) relationship : The relationship of mother **with** children **is** characterized by warmth and affection. During childhood **there is** no **difference in** the mother's treatment of a boy and a girl, and she **is** more responsible to take care of the children than the father. She looks after their daily need and personal requirements. A boy until he **is** matured and take part **in** the activities of men, **is in** close contact **with** the mother and grows up under her supervision. A son addresses **his** mother by the term *auvai* and she **in** turn addresses her son by name or other terms like '*ayyan*' or '*ponnan*' when he **is** young. But after **his marriage**, a mother usually addresses **her** son using tecknonymous term.

During childhood, a son is more free towards **his** mother than father. After adolescence, he becomes free from the mother and she **will** not **have** much control over **him**. On reaching maturity, a son starts making his earnings and manages his own **affairs**.

The relationship between a son and a mother now becomes that of formal in nature and the interaction between them reduces

After the son establishing his independent household, a mother often visits him and take care of the children and assists in the domestic activity. Whenever her daughter-in-law is away or undergoing menstrual pollution, a mother looks after the household activities of her son. If widowed, a mother prefers to stay along with her daughter. **But**, if she **is with** her husband, stay in separate hut depending mostly on son. A son has concern and affection for **his** mother though these feelings are not always apparent. He **is** responsible to take care of **his** mother when she **is old** or becomes widow. Thus. Ramanan of Thaze-Abbannoor often says that **his** greatest desire **is** to erect a comfortable hut and bring **his** old mother from **his** sister and to keep her along **with him**, taking care of her in her old age, and thereby fulfilling **his** responsibility.

A mother interferes **in** matters regarding her son's marriage especially when **it is** with her brother's daughter. In such cases she **will** be the **main** person to initiate the matter and she actively participate **in** the discussion and decision making. Other than **this**, usually a mother **will** not interfere **in** the personal affairs of a matured son and to certain extent she **will** be keeping away from **him**. If son happens to be sitting **with** others outside the hut, a mother **will** not usually **join** the group, and a son rarely **tries** to keep away from **his** mother's presence while smoking

In here absence, **it is** the son who represents **his** mother **in** her natal hamlet during ceremonial occasions and contribute **his** mother's **share** as *petta pillai panam*. **Also**, **it is** the son who **is** obliged to **give** the *kattakal- panam* of **his** mother to **his mother's** brother's children at the **time** of **his** mother's **funeral**

Mother (*auvai*)-daughter (*maka*) relationship : The relationship of **mother** and daughter **will** be characterized by love and **affection**, but unlike **son**, a mother **will** have more control and authority over her daughter. Their relationship **is** also based on mutual co-operation and obligation. A daughter addresses her mother by the term *auvai* and she **in** turn addresses her daughter by name or other terms such as '*amme*' when she **is** very young or '*ponni*' when she is grown up. But **tecknonymous** term **is** used to address after her marriage. By the age of eight to **ten**, a daughter **will** be trained in all household

activities by her mother. By helping and assisting the mother, a daughter gradually learns the household activities like fetching water, cleaning utensils, sweeping- pounding, collecting fire wood, caring the children etc. She also accompanies her mother to the farm and **help** her **in** sowing, weeding and other minor agricultural activities. In the absence of a mother, **it is** the grown up daughter who manages the household affairs. A mother actively involves **in** the **marriage** negotiation of her daughter and makes decision regarding the choice of the mate for her daughter.

The relationship between a mother and a daughter is very informal; gossip and joking as well as ordinary dialogue among them include discussion on sexual matters. It **is** not uncommon to see a mother and a daughter smoking together, and while sitting in a group they even share the same **beedi**.

After marriage, a daughter separates from her mother and goes to **live in** her husband's hamlet. But she tries to retain the same relationship through occasional visits. At Thaze-Abbannoor, **Ragi's** eldest daughter **Chelli**, though **married** to Anakkal hamlet **is** maintaining close relation **with** her mother. **Chelli is** cultivating a portion of the farm land at Thaze-Abbannoor which **is** belonging to her mother. Since both hamlets are nearby, Chelh visits her mother often when she comes to work **in** her farm land. **Ragi** offers *kanchi*, **if** there **is** some, to her daughter and **grand-daughters**. Similarly, **Ragi** also visits her daughter at Anakkal. The close relationship between the mother and **the** daughter becomes more clear when **Ragi** took the responsibility of looking after and herding the goats of her daughter for which she **will be paid in kind**, usually one or two young goats.

A widowed mother prefers to stay along **with** her daughter and she assists her **in** domestic affairs and other agricultural activities. Even **if** the mother **is** staying in a different hut, a daughter always care for her mother and gives a daily share of night food. The exchange of labour and food is frequent between the mother and the daughter and they visit each others hut daily. A woman prefers to **give** her personal belongings, mainly ornaments to her daughter.

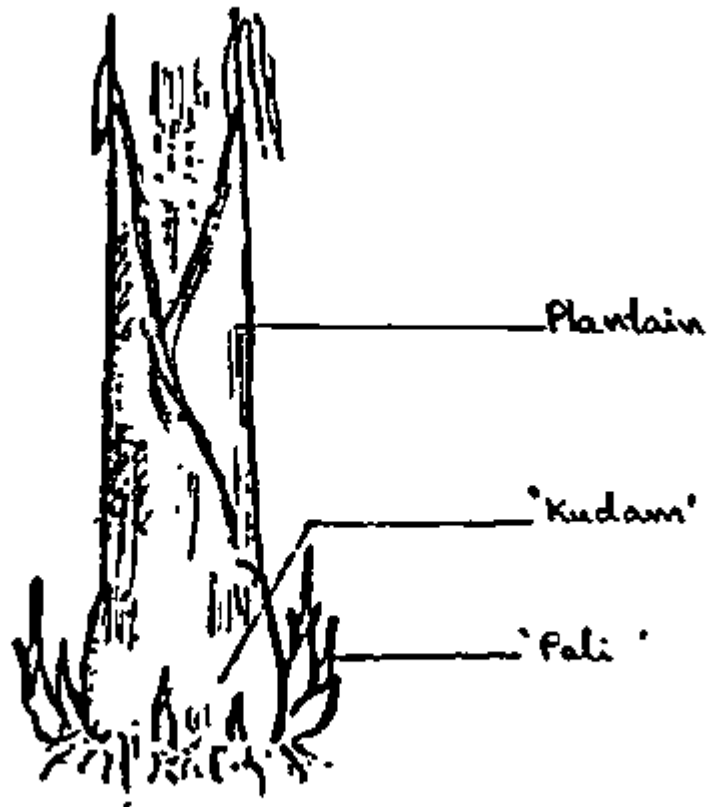

Fig 5 12 Vegetative propagation as an analogy for parent child attachment

It is to be mentioned here that, while talking on kinship, the Muduuas often use the vegetative propagation as an analogy for parent-child relationship. In the context of vegetative propagation, people differentiate two main components for a **plantain--th** base or com and the seedlings. They describe the base of a plantain as *kudam* which represents a mature entity, such as a matured person as a source of progeny. As the plantain matures, small seedlings sprout out from the **main** base (*kudam*) and are seen encircling **its** penphery. **This** small seedlings represent younger ones and **is** termed as *pali*. The *pah* later matures and **it** also produces seedlings and thus the process of propagation continues. When people say "*auvai-appan vannu kudam, emma pali*", the analogy characterizes the parent, especially mother as the base of origin to **which** the children are attached and depicts the process and continuity of propagation.

Brother's (*annan-thampi*) relationship : After the father-son relationship, the strong bond of descent exist between brothers. The relationship between brothers are strong as they are members of the same corporate group throughout their life. If the brothers are of similar age group, they behave more friendly and the relationship is not characterized by formalized pattern of behavior. Brothers who are near in age grow up as playmates co-operating in various activities and work together in their father's farm land. The relationship is one of friendliness and they indulge in mild joking. If there is a great disparity in age between brothers, their relationship will be characterized by respect and distance. Younger brother addresses **his** elder brother by the term *annan* and he **in turn** addresses **his** younger brother by name or by the term '*ponnan*'.

An elder brother **is** having right and authority over the **younger** brother and their behaviour **is** more of a formalized nature. They rarely move together and most often avoid sitting together **in** the same group. A younger brother **is** obliged to do the task assigned to **him** by and elder brother. The behavior **is** of mutual understanding characterized by a younger brother's respect for the elder one, and their relationship **is** mostly of a father-son relation. **In** the absence of the father, **it is** the responsibility of the elder brother to arrange the marriage of **his** younger brother and to make the **bride-price** payment for **his** younger brother. At Thaze-Abbannoor, **it was Vella who** took the initiative and managed the entire expenditure to arrange the marriage of **his** younger brother **Panali**. Since very old, their father Chonke was not capable of managing the affair.

Similarly, **it is** the younger brother who **is** responsible of paying the **bride-price** of **his** elder brother **if** any balance amount **is** remaining at the funeral of **his** elder brother. After the death of an elder brother, **it is** the obligation of a **younger** brother to **show** concern and care for **his** elder brother's widow and **his** young children. At Thaze-Abbannoor, **it is** Bokken who had paid the bride-price of his elder brother **Mathan**, at the **time** of **his** death. **Mathan's wife** and children are now staying nearby **Bokken's** hut and he is taking care **of them**.

If elder brother **is** having no grown up **sons**, **it is** again the **responsibility** of **the** younger brother to pay for the **kattakal pidikkal towards** his sister's children at the **time** of

his elder brother's funeral In the absence of father, it is the elder brother who has to take care of his younger brother and he has the responsibility to bring him up in life. Ramanan of Thaze-Abbannoor always talks about the difficulties and strain he underwent in bringing up his younger siblings, especially in educating his younger brother chithambaran and in getting him a job. Even after getting job, Ramanan used to arrange money for Chithambaran whenever he is in need. Regarding this relation, Ramanan use to say “*oru appane pashe naan ennu thampine nodi irunthe*”, meaning that he had taken care of his younger brother just like a father caring his son

The elder most brother in a sibling group is regarded as the head of that generation and will be referred as '*thalakodi annan*' He receives more respect and politeness from other younger siblings Brothers try to reside together and treat each others children as ones own They **also** consider each others field as common and **co-**operate in agricultural activities There exist a great amount of sharing of labour and exchange of food between brothers

Brother (*annan/thampi*)- sister (*akka/thanke*)relationship There exist a strong bond of concern and also rights and obligation between a brother and a sister During younger days, a brother and a sister of same age group grow up playing and moving together By the age of eight to ten years, their interaction reduce and the **girl** spends most of her **time** in assisting her mother in domestic activities and a boy spends most of **his time** outside the house in the field or herding cattle If the disparity **between** their **age** is more, the relationship between younger sister and elder brother **is** characterized by **respect** and distance ¹⁸ A younger sister addresses her elder brother by name or by the term '*ponni*' A younger sister usually tries to keep away from her elder brother and do not **sit in the** group in which her elder brother **is** also present But between a sister and a brother of same age group, **mild** teasing and joking takes place

An elder brother have the right to scold **his** younger sister **if** he finds fault with her and at times he may also beat her on committing serious offences In the absence of father, **it** is the elder brother **who** takes responsibility of arranging the marriage of **his** sister. And, it is the brother **who** is having the right over **his** sister's bride-price in the absence of his father. After marriage, a sister moves out to **live** along with her husband **in**

his hamlet. However, the strong relationship of a sister towards her brother and the attendant rights and obligation persist. Whenever a brother visits her sister, he will be received with respect, and the sister touches the feet of her elder brother and get blessing from him. If a sister is residing in her natal hamlet with husband even after marriage, there exist frequent interaction between the households of a brother and a sister. A sister visits her brother's household and assist in domestic activities especially when her brother's wife is away or undergoing menstrual pollution.

The essential tie between brother and sister is expressed when the sister makes a demand over her brother's daughter as bride for her son and similarly when a brother claims her sister's daughter as bride for his own son. At Thaze-Abbannoor, since Rami had already claimed her brother Kakki's daughter to be mated to her son Murugan, Kakki was not at all encouraging any other proposal for his daughter Pavashi. But Murugan since in love with another girl from the same hamlet, was not at all agreeing for this proposal and kept delaying the marriage. Rami and her husband Chellan could know that if they fail to stick to their words, it will badly affect not only the sibling bond but the permanent link between the two families, and may even cause threat to their stay in the hamlet. Thus, they strongly forced their son for the proposed marriage, and after heavy pressure from his parents, Murugan decided to marry his MBD, Pavashi. This shows that the importance of alliance relationship between affinally related families is reflected on the bond between brother and sister.

Similarly, Aiyappan of Mukkali hamlet wants his son to be married with his elder sister Maruthi's daughter. According to him, Maruthi's daughter Laxmi is his right and he says that "it is a person's right to ask for the girl child of his sister for his own son". Aiyappan is thus trying to avoid all other proposals coming for Laxmi.

Though women do not have traditional right on their natal land, they however, when in need seek help and hospitality from their brothers, and at times are permitted to cultivate a portion of their land. The brothers are responsible to take care of their sisters if they come to them with their children seeking help. Thaze-Abbannoor Rangan's younger sister had been married to Puliyar's son at Gottiyarkandi hamlet. But due to frequent quarrel with her husband, Rangan's sister had to come back to Thaze-Abbannoor. She and her children are now staying along with Rangan. When asked to

Rangan, he replied "*ennuhine naan int ecche bidum.....?*" ("how can i leave the one which is mine?"). meaning that, since she is his own sister and had come to him, it is **his responsibility** to look after her and **the** children. This **shows** the strong bond **between** a brother and sister and a their mutual obligation persisting **even** after **marriage**.

Sister's (***akka-thanke***) relationship : The relationship between sisters is characterised by closeness and co-operation in household activities. Sisters of same age group from childhood spend most of their **time** together playing and moving about They grow up under the care of their mother and learn most of the household work and other minor agricultural activities together They **co-operate** together in assisting their mother in fetching water, cleaning utensils, collecting fire-woods, pounding grains and also **in** minor agricultural activities. If the disparity between their age **is** more, the elder sister shows concern and care for the younger and **will** have responsibility **in** bringing up the younger and training her ra household activities The elder sister exercise control and authority over her younger sister and she **inturn** shows respect to her elder sister A younger sister addresses her elder sister by the term '***akka***' and she **in** turn addresses her by name After marriage, they addresses each other by using **tecknonyms** terms

The behaviour between sisters of same age group **is** not of formal nature The relationship **is** one of friendliness They **join** together **in** the **same** group, **joke**, exchange secrets and freely **talk** on matters of sex. They do often smoke together and sometimes share the same **beedi** After **marriage**, **if** they are residing **in** the same hamlet, their intimacy and obligation towards each other **is** evident from their frequent visit to **each** others hut and the mutual sharing of food and labour. **In** the absence of her elder sister, the younger one takes care of **the** elder sister's household activities and look after **her** children They treat each others children as ones **own**. Whenever sisters are married to brothers, the intimacy and obligation between them **is** more and they usuall> reside **in** **adjacent** huts and **co-operate** and assist **in** all domestic **activities**

Grand-parents (***acchan/acchi***) –**Grand-children (*perar/perathi*)** relationship : The relationship between grand-parents and **grand-children is** one of friendliness and **is** not characterized by formalized pattern of behavior. There exist great closeness and

affection between grand-parents and grand-children. A man shows fondness for his grand-children and gives them companionship. The grand-father is the best friend of a child and at times he spends time with his grand-children telling stories, joking and moving together. A woman **is** also very close **with** her **grand-children** and have more love and affection towards them. A grand-mother may give moral advice and worldly wisdom for their grand-children especially **grand-daughter** and trains her in household tasks. Grand-parents take interest **in** the rites and ceremonies connected with their grand-**children** and have a few customary obligations **towards** them.

There **is** no much difference in a child's behavior **towards his** paternal and maternal grand-parents. Both maternal and paternal grand-fathers are **acchan** to the child and both the grand-mothers come **in** the **kin** category **acchi**. As far as rights and obligations are concerned, the son's children are treated different **from** daughter's children. A grand-father **is** having the right to get a share of the **bnde-price** of **his** son's daughter and at the same **time** he **is** also responsible to contribute the bnde-price for **his** son's son. But as far as daughters children are concerned, he **is** not having such rights and obligations.

It **is** from the grand-parents that the children **learn** songs, **proverbs, riddles** and other traditional lore. During night **time**, children gather **in a** corner of the hamlet and **sit** along **with** their grand-parents listening to **stories** or singing songs and dancing. **The** grand-parents are felt to be the living links **with** the past.

Mother's brother (**maman**)-**sister's** son (**barmakan**)relationship : A **sister's** son's behaviour towards a mother's brother **is** always **characterised** by politeness and distance. Even though the mother's brother do not enjoy much authority over **his** sister's **children**, their behaviour **is** of a formal nature. A sister's son usually keeps **away** from **his** mother's brother which can be seen as a **sign** of respectful distance. Sister's son addresses **his** mother's brother by the term *maman* and he **in turn** addresses **his** sister's son by name or uses tecknonymous term **if** he **is** married. The mother's brother enjoys right over the sister's children who **is** expected to render him ordinary domestic services and assist **in** agricultural activities. A mother's brother **is** having the right to invite his **sister's** son to **his** hamlet to stay along with him and work for **him**. At **Thaze-Abbannoor, kakki was**

often seen employing his sister's son Murugan to work in his farm land along with his son Kakki is having the right and privilege of asking Murugan to come and work in his farm land whenever needed

A sister's son will not usually get along with the mother's brother and **will not join** the group **in** which **his** mother's brother is also **present**. It is not common to see a sister's son smoking **in** the presence of his mother's brother.

The right of the **mother's** brother over his **sister's** children last till his sister's **bride-price** **is** totally **paid** by **his** sister's husband's group. Once the **bride-price** is totally **paid**, the right of mother's brother over **his** sister's children ends and he symbolically hand over them to **his** sister's husband's family (This **is** done during the *pariyamkettal* ceremony associated **with** the funeral)

If a woman **is** divorced by her husband or becomes widow **in** the early stage of her marriage, she returns to the natal land along **with** her children. In such cases, a mother's brother **is** likely to feel more responsible to **bring** up the children and to care for them. Here, the sister's husband's group can claim the children only after paying a fee called *sakkukoo* to the children's mother's brother for bringing up the children.

The relationship between mother's brother and sister's son **is** a correlation of rights and duties. It **is** the mother's brother, **in** the absence of **his** father **who** has to reciprocate **his** sister's **bride-price** by giving a cattle to **his** sister's husband's group which may go to **his** sister's son. At the funeral ceremony of **his** mother's brother, a sister's son **is** having the right and privilege of creating obstructions. Thus, while taking **the** corpse of the mother's brother to the burial ground, the sister's son obstructs and stops the procession by holding the leg of the bamboo platform (*kattakaal*) on which the corpse **is** laid (**this is known** as *kanakaai pidikkal*). The sister's son recedes only **if** he **is** assured that he **will** be given a cattle later by **his** mother's brother's children and as a **sign** of assurance, a metal pot or a knife **is** given to him.

At the **time** of his marriage, a man **is** obliged to pay an amount of rupees **10 '4** to **his mother's** brother as *thaimaman panam* (mother's **brother's fee**), **if** he is not **marrying his MBD**. Similarly a sister's daughter also has to pay an amount of rupees **10 '4** to **her** mother's brother **if** she is not getting married to her MBS. A sister's son and sister's daughter **will** have almost similar pattern of behaviour **towards** their mother's brother.

The mother's brother can claim his sister's son for marriage with his daughter. A sister's son is obliged to stay along with his mother's brother and do service for him. if he **is supposed** to marry his MBD. **In** certain cases, after marriage, a **sister's** son continues to stay **with his mother's** brother and can clear and cultivate a portion of his **mother's** brother's land **if he is** willing.

A sister's son has the right to seek his mother's brother's advice and practical assistance when needed and he feels more relaxed with a mother's brother than **with** his own father. He feels proud and prestigious of **his** mother's brother and talks great of him. Moreover, they do say that a man who **is** not having a **mother's** brother is equi**alent** to an orphan. Since **in** certain cases, members tend to reside uxorilocally after **marriage, it is** not uncommon to find a sister's son and mother's brother living **in** the same hamlet. **In** such cases the relationship of mother's brother and sister's son **will** be characterised by respect and distance. If **staying in** different hamlets, a mother's brother visits **his** sister's children especially during festivals and other ceremonial occasions.

The special position attributed to the mother's brother **in** all the **life-cycle rituals** of **his** sister's children **like** ear-boring, tonsure, and marriage ceremonies clearly expresses the right of mother's brother on **his** sister's children

Father's sister (mami)-brother's children (barmakka) relationship Father's sister's relationship towards her brother's children is often characterized as one of authority and distance. A child usually fears and respects **his/her** father's sister **more** than **his/her** mother, and she **inturn** has **jural** authority over her brother's children. Children, especially boys keep away from their father's sister and their **behaviour is** more of a formalized nature. However, a girl's relation towards her father's sister **is** less formal than **that** of her brother and she gets along **with** her father's sister

The father's sister has the **right** to claim her brother's children **in** marriage **with** her son or daughter. A brother's son **is** obliged to go and stay along **with his** father's sister and work for her about three to five years **if he** is proposed to her daughter. At **the** funeral ceremony of **his father's sister**, a **brother's** son is **having** the right and **privilege** of creating obstructions and **in** claiming the *kattakaipanam* of **his** father's sister. **It is** the

brother's son who is having the right over his father's sister's bride-price in the absence of his father

Mother's **brother's** son (*machan*) -Father's **sister's** son (*machan*) relationship :

Among all relationship, the most friendly and close relationship is **between cross-cousins** who fall in the kin category '*machan*'. A **cross-cousin**, particularly one **who** is of the same age-group, **is** a person **with** whom a **man's** behaviour can be very free and informal. They tease each other, exchange secrets and discuss matters on sex. Cross-cousins address each other by the term '*machan*'

Though the behavior of **cross-cousins** are friendly and informal, their relationship **is** a correlation of obligation and duty. The most significant relationship between the members of affinal related families **is** provided by the relationship between **cross-cousins**. The **cross-cousins** are obliged to pay each other for the *kattakal-pidikkal* of their parents. Thus, a MBS has to pay for the *kattakal-Pidikkal* of his father to **his** FZS and FZS has to pay for her mother's to **his** MBS.

When cross-cousins are immediately related through marriage (i.e. **ZH-WB**), their relationship **is** more of obligation mixed **with** politeness and respect. They are having more concern and intimacy towards each other and **co-operate** in their agricultural activities. They are more attached and obliged to help each other. It is the cross-cousin who are immediately related through marriage from whom a man can expect all **sorts** of assistance and aid when one **is in** need. Thus when **Mele-Abbannoor Panali's** hut got completely damaged and had no other place to sleep, **his machan, Nanjan** who was residing nearby gave **his** hut to **him** and moved **with his** family to **his** hut in the farmland. When asked about this, Nanjan **said**, "**Panali is my machan, and when he is in trouble, it is we who have to help him, and it is not good to keep our eyes closed when our machan is struggling without a place to sleep****"

Cross-cousins who **are** not immediately related by marriage have **joking** relation more than any person and can discuss **any** matter openly **without** restriction. Their relationship is not characterised by politeness and **respect**. In certain cases, they **may** even behave **like** children teasing each other and entering in 'funny' activities. The degree of this informal relation **existing** between **cross-cousins** becomes **very** clear **in**

their common saying "*machan mathiri vilayadathe__*" meaning, do not play like *machan*

It **is** the persons who are **in** the **kin** category '*machan*' who interact more and move about together. A person **will** be seen often in the company of his *machan*. Since one **is** more free **with** his *machan*, he prefers the company of **his** *machan* to go for hunting, collecting honey, cutting bamboo **etc.**, **from** the forest.

Mother's brother's daughter (***attiai***)-Father's sister's daughter (***attiai***) relationship :

Like male cross-cousins, **this** relationship is also characterised by **friendliness** and closeness and the behavior **is** very informal. **This** is an exact replica of the relationship between male cross-cousins. By the age of eight to ten, female **cross-cousins** are seen moving together and they **co-operate in** most activities. They have a joking relation and are free and at times tease each other. They **join** together **in** the same group, exchange secrets and talk on matters of sex. They do often smoke together and sometimes share the same **beedi**. Female cross-cousins address each other by the term ***attiai***.

The relationship between cross-cousins **is** a correlation of obligation and duty. When a **girl** on attaining puberty and has to remain secluded for seven days, **it is** her ***attiai*** who assist her as ***thunakkari*** (friend) for the entire period. She attends to all her needs and serve food for her. Similarly, during child birth, **it is the *attiai* who** usually come forward to take care of the mother and the child. She **is** obliged to look after them and prepare special food for the mother and also make hot water to bathe the child. The right and obligation of **this** strong and intimate relationship culminates **when** their children enter **in** marriage relation.

Relatives **by marriage** :

The marriage between **two** persons brings together the members of their **respective** *patnhneal koottam* in an alliance relationship. **However, in** practice, **only** a limited range of persons become involved **in** the viable affinal **relationship** such **that, certain** characteristic behavior pattern exist **between** persons **who** are **immediately** related by **marriage**. Genealogical proximity to a great extent determines the interaction **between** members of **affinally** related families.

Husband's father-son's wife relationship : A woman's relationship with her husband's father is characterized by avoidance and distance. Her behavior towards him is that of an highly formalized pattern. She restricts herself from coming in front of her husband's father and avoids sitting inside the hut when he is alone. A woman will **never** address her husband's father or utter his personal name. She even avoids addressing others by name **if** they are having the same name of her **husband's** father. Similarly, a **father-in-law** avoids addressing **his** daughter-in-law. Thus **when** asked to **Malli** about her husband's father's name, she **did** not answer directly. She replied by saying : "you know my daughter's husband's father's name ?, ...the same".

A woman uses the term **maman in** referring to her **husband's** father and he refers to her by the term **barmaka** or by tecknonymous term. A son's **wife** will not directly serve food for her husband's father and when her mother-in-law **is** away, she may keep the food and call **him** by sending her children. They **will** avoid exchanging things hand to hand. On the way, **if** a woman happens to see her husband's father coming from the other side, she keeps away from the path until he passes. The Mudugas use the **term** "**nangrathu**" to refer to **this** avoidance relation existing among them. Regarding **this** type of relationship, people say "**barmaka vanthu mamane nangadom**" meaning, a daughter-in-law should avoid her husband's father.

Wife's mother-daughter's husband relationship : Respect and regards are expected from a man **in his** behavior towards **his** wife's mother. He has to be treated as a respectful guest by the mother-in-law. There **is** some formalities **in** the behavior of **both**, and they avoid appearing face to face ¹⁹. A woman **will** not **join** a group **in** which her **son-in-law is** also present and she usually avoids smoking **in** the presence of her son-in-law. A **mother-in-law will** not serve food directly for her daughter's husband. When her daughter **is** away, she may keep the food and **invite him** by sending **children**. In the absence of others, a mother **-in-law** and son-in-law **will never** stay together inside the **hut**. Either of them **will** go out of the hut. A man never addresses **his wife's mother**, and she **will** also avoid addressing her **daughter's husband**. However, a man **refers** to his wife's mother as **mami** and she refers to her daughter's husband as **barmakan** or use **tecknonymous term**.

Konthan (HeB/yZHms)-kontif (WeZ/j BWms) relationship : This relationship exist between certain category of persons who are immediately related through marriage. For a man, his wife's elder sister and younger brother's wife fall in the category of *konthi* and for a woman, her husband's elder brother and younger sister's husband is in the kin category of *konthan*. The relationship between *konthan* and *konthi* is characterized by avoidance giving a highly formalised pattern of behavior similar to the above two sets of relationship. But compared to those two sets of avoidance relationship, the degree of avoidance is more in the *konthan-konthi* relationship.

Persons who are in the relationship of *konthan-konthi*, will avoid coming face to face or talking each other. A *konthi* will never join the group in which her *konthan* is also present and avoids smoking in the presence of him. Persons who are in this avoidance relationship will never address each other and they usually use **tecknonymous** term or the terms *konthan* and *konthi* to refer the other. A woman will also avoid addressing a person by name if he is having the same name of her *konthan*. There is very little contact between a woman and her husband's elder brother with whom she should maintain some distance. Marriage between the two in the event of divorce or death of the spouse is permitted by rule. However, a person rarely agrees to marry a woman who is *konthi* to him. Thus, at Thaze-Abbannoor, when Velli's wife Neeli expired, his close relatives proposed him to marry his younger brother's wife who is a widow. But he was not at all willing for the marriage and outrightly rejected the suggestion by saying "oru neppillatha nayam" ecche *konthine kalyanam mudikkuve?*" which carries the meaning that it is too senseless to ask a man to marry his *konthi*.

The very nature of this avoidance relationship is well depicted in one of the Muduga riddles, "thannikku *konthan aaru?*" (who is *konthan* for water ?) The answer is "chembila"- the leaf of a **colocassia** plant. This means that the leaf of a **colocassia** plant will be like *konthan* for water. In this analogy, water is equated with a *konrht*. which on colocassia leaf- the *konthan*, becomes uneasy, rolling about here and there on the leaf surface and finally escapes out. Similarly is a *konthi's* behavior who feels uncomfortable and escapes away when happens to come in front of her *konthan*. No other explanation could so aptly depict the characteristic nature of this relationship than the native analogy of water and colocassia leaf.

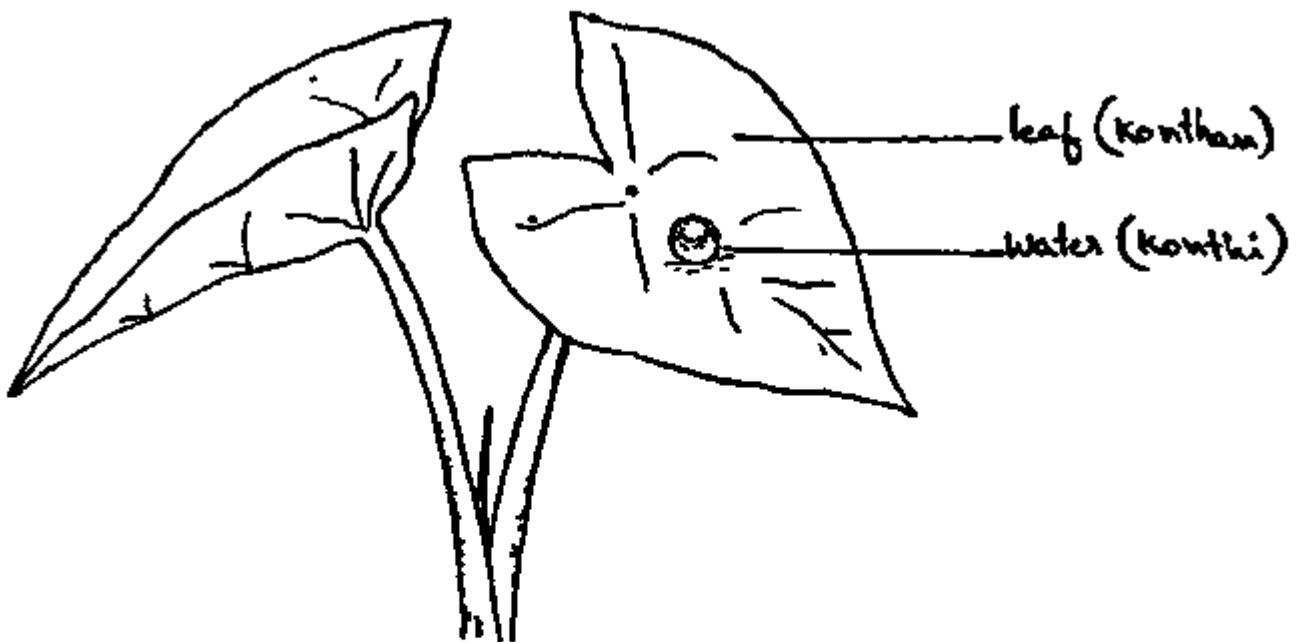

Fig 5 13 Analogy of *konthan-konthi* relationship

Among the Mudugas, there is often seen a correlation between avoidance relationship and sororate / levirate marriage practices. Thus a man, after the death of **his wife**, can and **is** permitted to marry **his** wife's younger sister, but **will** not marry **his wife's** elder sister **with** whom he **is** having avoidance relationship. Similarly, after the death of her husband, a woman may be **married** by her **husband's** younger brother and not usually by her **husband's** elder brother **with** whom she **is** having avoidance relationship.

Though a man **will** be having avoidance relationship **with his** younger brother's wife, he **will** maintain a joking relation **with** his younger brother's **wife** elder sister, **with** whom **his** younger brother avoids. **This** clearly shows that, the rule of '**same-sex** sibling equivalence' **will** not work out **with** regard to avoidance relationship. **Thus**, for a man, **his** younger brother's wife's (a linking relative) elder sister (same sex sibling), **is** not equivalent to the former as **konthi**. **Kakki** of **meleabbannoor** is having a friendly and informal relationship with his younger brother Mani's wife's elder sister **with** whom

Mani is having an avoidance relationship. Kakki addresses her by the term *attiai* and she in turn addresses him by the term *machan*. However, when Kakki avoids Mani's "wife," Mani is having a joking relationship with Kakki's **wife**.

It is to be mentioned that, the high degree of avoidance relationship exists between members who are immediately related through marriage **i.e.**, own sibling's spouse or spouse's own sibling. The avoidance relationship will not be much strong when they are distantly related **i.e.**, classificatory sibling's spouse or spouse's **classificatory** sibling, even though they fall in the **kin** category *konthan* and *konthi*. Moreover, the degree of avoidance and the severity of constraints between a *konthan* and *konthi* may be relaxed somewhat in old age. For a man, his wife's elder most sister **will** be *thalakettu konthi*. The degree of avoidance towards **his** *thalakettu konthi* **will** be more when compared to **his** wife's immediate elder sisters.

The relationship of a woman **with** her husband's younger brother **is** characterized by closeness and an informal behavioral pattern. They talk freely, engage in gossip and may tease each other. A man addresses **his** elder brother's **wife** as *attiai* and she in turn addresses **him** by the term *machan* or **if** he is named, uses a tecknonymous term. They say that a man's elder **brother's wife** though *attiai* **will** be equivalent to *avvai* behavior. She shows care and concern towards her husband's younger brother. The **wife** of the *thalakettu annan* (elder most brother) **is** known as *thalakettu attiai* and **is** considered more than a mother. She **is** the first woman to enter the hut (*aadyam kooraipukkinathu*) and **will** have more right and authority **in** the household affairs.

Similarly, a man **will** have an informal and joking relationship **with** his wife's younger sister. They talk friendly and may indulge **in** mild teasing. **Behaviour** between them **is** on the whole very free without any fixed **expectation** or restrictions. A man addresses **his** **wife's** younger sister as *attiai* and **she** in turn addresses **him** by the term *machan*. It **is** to be mentioned that, **if** a man's younger brother **marries** **his** wife's younger sister, then the nature of relationship **will** be shifted to that of **avoidance**. Not only a **wife's** younger sister, but any woman **if** married to **a** **man's** younger brother **will** develop an avoidance relationship. At Chittoor **hamlet**, **Chinnaswami** was having a **very** close and informal relationship **with** **his** **classificatory** MBD **Lakshmi**. They talked freely and **used** to indulge **in** minor teasing. But later, **when** Lakshmi **was** named to **his** younger brother

Sivaraman, Chinnaswami's relationship towards Lakshmi changed totally to one characterized by avoidance and restrictions.

Husband-wife relationship : The relationship between a husband and a wife is not characterized by formalized pattern of behavior. A husband does not enjoy much authority or control over his wife and they behave freely and consider each other as equals. Though the husband's position is regarded as one of superior to that of his wife, there is no explicit sign of respect and politeness in the behavior of a wife towards her husband. A wife **will sit** along **with** her husband in the *group* and participate **in** talking and gossiping. If the **wife** happens to be sitting while the husband **enters**, she never stands up as a symbol of respect. They consider each other as equals. Both husband and **wife** have equal **responsibility in** the family affairs. However, **it is** the **wife** who manages and controls the household activities and a man **will** be mostly spending **time** outside the hut **in** the field and **in** the forests. A man **is** responsible to earn money and provide the necessary requirements for the household and **it is** the duty of a woman to cook and serve food for her husband. A lack of responsibility **in** managing the **expenditure** of the household affairs from the **side** of husband **will** lead to severe criticism and heavy scolding from the **wife**. She may even dare to scold the husband **in** front of others.

Among **Mudugas**, women are never meek or **submissive** to their husband. A husband and a **wife** are usually seen smoking together and they **even** share **the** same **bed**. A woman while addressing or talking to her **husband**, add the affix **"-me"** and **the** husband uses the affix **"-pe"** both of which are **used** for persons of same generations or younger ones.

During the first few months **of** marriage, a **wife will** not be much interacting **with** the husband and avoid each other in the presence of **others**. **If** frequent quarrels occur between husband and wife, she may strain her relationship with her husband and return to her natal hamlet. After separating from the husband, a woman may often get married to another man. In their old age, an husband and wife will be more loyal and their behavior is characterized by concern and care for each other.

Generational equivalence of Kinship behavior:

A close observation and further analysis of the Kinship behavior pattern among the Mudugas shows some features of intergenerational equivalence of behavior. Thus there is a tendency of behavioural assimilation of certain **categories** of kin in one generation with the kin categories of adjacent generation that are of the same crossness- However, it is to be mentioned that this tendency of equivalence is only with behaviour and is not at all reflected in the terminology. The major criteria operating in this intergenerational merging of behaviour is the age and sex factor, such that elder members of junior generation and younger members of senior generation who are of the same-sex fall in the same behavioral pattern

It is noted that the behavior of a younger brother towards his eldest brother who is known as *thalakettuan* will be often characterized by respect and distance. Their relationship is almost similar to that of a father-son, with the elder brother having more authority and control over the younger brother. As an extension of this, the wife of *thalakettu annan* who is *thalakettu attai* is equated to a mother in behavior. This equivalence shows that a man will be having similar pattern of behaviour with his eldest son and youngest brother and hence his relationship with his son's wife and younger brother's wife will also be in the same pattern

Similarly, a man's behavior with his elder daughter and youngest sister can be equated such that eldest son-in-law and younger most brother-in-law (*machan*) will be also in the same behavioral pattern. A man will have the similar respect and distance with his eldest sister (*thalakodiakka*) and his father's youngest sister and hence elder sister's husband (*machan*) and father's younger sister's husband (*maman*) will also be of the same behavioural pattern. Also noted is that, a man's father's elder brother and his father's father will be in the same relationship towards him

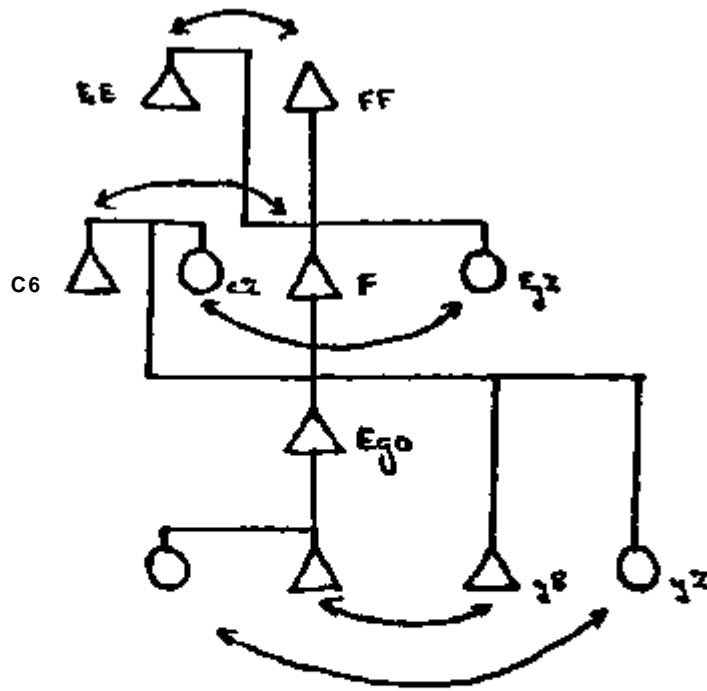

Fig 5 14 Generational equivalence of kinship behaviour:

Intergenerational equivalence of behaviour becomes more evident and can be clearly depicted when in certain case marriage occurs between persons of different generation giving rise to a shuffling in kinship terminology. Here, often the **generational level** with respect to the immediate kin is given importance. A case in support of this is that of Thaze-Abbannoor Bokken's mamage. Bokken had married his father's third wife Neeli's younger sister Vanji who was in the category *sinnawvai* (MyZ) for him. Because of this intergenerational union, a merging in the mode of behaviour among persons of adjacent generation had taken place. Before mamage, Bokken used to address Vanji's brother Knshnan who is his father's *machan* as *maman*. But now he treats him as *machan*. Krishnan's son Mani eventhough addresses Vanji as *sinnawvai*, addresses Bokken as *machan* even after their mamage. Neeli's son Raju eventhough addresses Bokken as *annan*, his wife Vanji is still *sinnawvai* for him, since she is more as a 'mother's sister' for him. The relationship between Raju and Vanji, which is charactenzed by love and affection is continuing in the same pattern even after Bokken's mamage with Vanji, which shows the behavioural similarity of these two kin categories.

ie, elder brother's wife (*attiai*) and mother's younger sister (*sinnavai*)- Similarly Kakki's son Chandran, borne for Neeli, addresses Bokken as *annan*, but Vanji as *sinnavai*. For Raju's wife Mathi, Vanji should be in the category *akka*, since she is her husband's elder brother's wife. But Mathi considers Vanji as *mami* even though Bokken is *kontham* for her, thereby depicting the equivalence of *mami* with *akka* and *maman* with *kontham* (husband's elder brother). Moreover, it is to be mentioned that once when Bokken's FZS, Rangan addressed Bokken's wife as *akka*, she corrected him to address her as *mami*.

The relationship of Bokken's younger sister Pavashi with Vanji is that of *attiai* (BW-HZ). Important to be noted here is that, Bokken's children address Neeli as *balhauvm* since she is more as mother's sister for them and also address Neeli's husband, Kakki who is their father's father, as *balliappan* (see Fig 5 15)

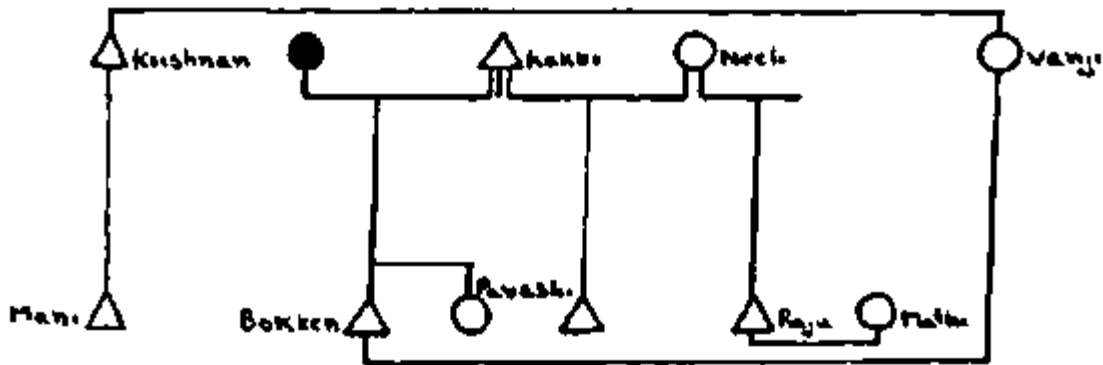

Fig 5 15 Genealogical representation of Bokken's marriage

Another case of this terminological overlapping is that of Gundi's relationship with Nanji at Thaze-Abhannoor hamlet. Gundi once while talking to Nanji addressed her as *maku* but she immediately sensed the error and added, "*oru muri maka, oru muri acchi*", which means that in one *murai* she is daughter and in other way Gundi is grandmother for Nanji. Thus, Gundi is related to Nanji in two *murai*, she is both father's elder brother's wife and mother's mother's wife's sister for Nanji.

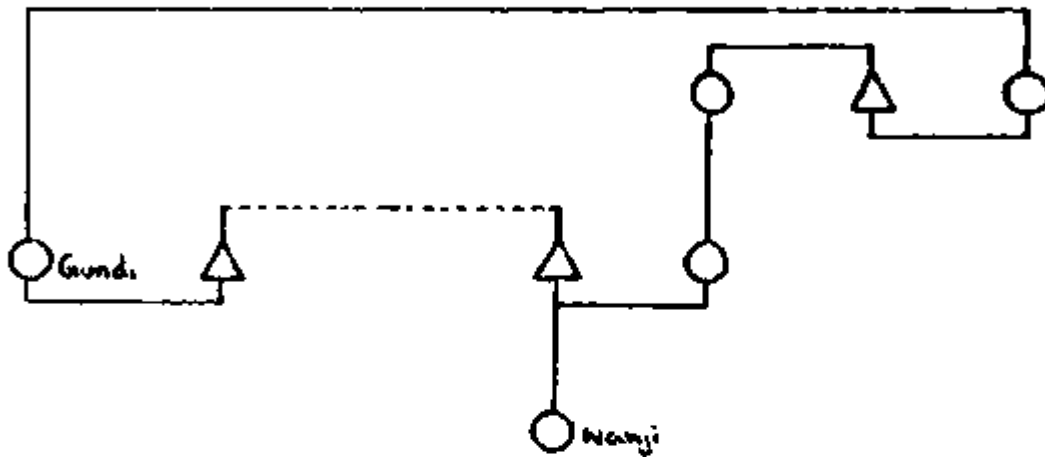

Fig 5 16 Genealogical representation of Gundi's relation with Nanji

Analysis of the Muduga kinship behaviour thus shows that there exist a tendency to assimilate categories of kin in one generation with kinship categories in generations adjacent with it that are of the same crossness. There exist a possible tendency for an equivalence in behaviour between categories of younger km in the ascending generation with those of the categories of kin in adjacent descending generation.

However, the Muduga kinship behaviour and marriage practices goes in conformity with the formal paradigm of Muduga kinship term which manifest the alliance between the two affinally related *koonam* characteristic of a two-section system. As the two-fold nature of consanguinity and affinity of the Muduga kinship extends far beyond the boundaries of one's own *koonam*, the behavioural pattern seen inside the kin group boundary can also be seen extending outside to those who fall in these categories.

NOTES

- 1 Dumont (1983 : 3-35) uses the label "consanguines" and "affines" for distinguishing these two categories of relatives, but Good (1981) argues that, the label "Parallel" and "Cross" is more neutral.
- 2 The Muduga language belongs to the **Tamil-Malayalam** sub group of South Dravidian with **neumerous** archaic features and strong Kannada influence. The **areal** feature or the phonological development of V > b -**typical** for all Kannada - like **languages**, is also shared by Mudugas (see Zvelebil 1985; Kapp 1978, 1980).
- 3 According to Good, **Dravidian** system have a terminological prescribed category and "a man has to marry a junior cross-relative of his own terminological level and a woman a senior cross-relative of her own level" (1981 115)
- 4 Since son (*makan*) and opposite-sex sibling's son (*marumakan*) are distinguished from one another by the addition of the prefix "*maru*", Dumont sees more of similarities between the words than difference, and assumes **that** the cross parallel distinction is very weak **in** the first descending generation Dumont seems to equate the usage of prefix *maru* with that of *ballia/sinna* used for age distinction among first ascending parallel relatives
- 5 Thus according to **Scheffler**, since Dumont argues that "**consanguines**" and "**affines**" represent entirely different categories, **there is** no logic **in** concluding that there exist only one fundamental category **Scheffler** says, "**Dumont's** interpretation would be tenable **if** and only **if** **affines** were a special **kind** of **consanguiness**" (1984 · 569)
- 6 Trautmann (1981) identifies, "**same-sex** sibling merging **rule**" and "opposite-sex cross-cousin-spouse equation rule" as the most important rules operating to reduce extended **kin** types to the focal **kin** types **in** Dravidian kinship
- 7 ACMayer (1960), uses "**kindred of co-operation**" to refer to **this immediate** connected relatives forming the core of **kin** terminological system consisting of close agnates and **affines**. While, the term "**kindred of recognition**"** is used for wider circle of relatives consisting of distant affines and **consanguines** connected **through core relatives**

- S *Kattakal-pidikkal* is the ceremonial right of a **sister's** son for claim in his mother's **brother's** share (especially cattle), by creating obstruction at the time of his funeral procession (for **detail**, see page 47 and also chapter 7).
- 9 Dumont (1983), argues that the main task of understanding **Dravidian** Kinship system **is** to understand the categorical distinction of relatives into **two classes** which forms the basic underlying **principle**.
- 10 According to Scheffler (1984 : 571), the expression of this categorical distinction are semantically narrower since they refer to males only and **it signifies** intergroup rather than interpersonal relations.
- 11 Rudner says that **Tamilians** use the term "*pankali*" to refer only to members of the descent groups and are not extended to non-marriageable members, "**even** when **non-pankahs** were nevertheless subject to classification by **kin** terms that anthropologists label as parallel or **consanguineal**" (1990 163)
- 12 For some Tamil non-Brahmin and Brahmin castes, **Kapadia** (1994) noted **that**, the more commonly used terms to represent parallel and cross **kin** are "*anna-thampimurai*" and "*maman-maccinnan murai*" respectively. **However**, "*kalyanamurai*" and "*pankali*" are more formal terms to represent cross and parallel **relatives** respectively. Similarly, David (1973) uses the terms "*annathammulavarasa*" and "*mamala varsa*" for parallel and cross relatives
- 13 Tambiah (1973 • 124-25) and Burkhart (1978 : 172) agrees **with Dumont's view when** they say that the unmarked **term** are fundamental and **the** marked terms or subcategories less important. However they remark that these marked terms are to emphasize the genealogical closeness within **the kin category**
- 14 Polysemy **is** the condition **in** which a particular expression has **two** or **more** co-contemporary and **logical ly** related senses, **one** broader or more general than **the** other or others. If the broadest sense is **derivable logically** from the narrowest or most specific, that polysemy **is** by sense generalisation. If the **narrower** or more specific sense **is** derivable logically from the broadest, **that** polysemy **is** by sense specialisation.

- 15 It is pointed out that the existence of reciprocal sets make kinship terms susceptible to structural analysis Good (1985 : 546) argues **that** though Dumont fails to realise the importance of reciprocal sets, **in** the structural analysis of kinship terms. **Scheffler** (1984), who himself **is** the propounder of the principle fails to apply that.
- 16 This has also been emphasized by **Kodanda** Rao (1952 : 214) when he says that "modifiers" are used differently for **consanguines** and **affines** such that **in** the former, **it** is used for distinction of relative **age** but for **affines** they are used to separate those **who** are genealogically related from those who are not.
- 17 *Pettapillai panam* literally means "**female-children's money**", is an obligatory contribution made by the females during the bride-price payment of any of their **agnatic** members
- 18 The **high** degree of incest taboo prevalent between a brother and a sister **is evident** when the most abusive language among them used against a man **is** to allege **him** of having sexual relation **with his** sister, (*akkane oh*) Similarly **the** most **abusive word** used against a woman **is** to allege her **of having** sexual relation **with** her father (*appan oh*)
- 19 Avoidance relationship **is** treated as an expression of tensions created by social and kinship structures, and **is** a mechanism which expresses and diverts potential conflicts A structuralist **approach, however,** would examine not only **the** relationship itself but **its** position **with** regard to other relationships • avoidance relationship may exist not so much because of tensions inherent **in the** relationship itself as because **it** forms a structural opposition to another relationships **which** together forms the structure of **kin** attitudes Recent **investigation** by Pans shows that "**avoidance** between son-in-law and mother-in-law **is** associated **with culturally** expected exchange of economic interaction between these **relatives**" (1998 71) **This** association of avoidance and exchange of economic service, according to **him,** suggests that avoidance relationship **is** a cultural **device** for distinguishing **the** relationship between **son-in-law and mother-in-law** from the **husband-wife** relationship **in** societies where these relationships tend to **be** similar as far as their economic aspect **is** concerned.

MARITAL EXCHANGE AND ALLIANCE RELATIONSHIP

Marriage is an important institution **among** the Mudugas which involves a kind of exchange of persons linking families and descent groups and the various forms of compensation payment. **Muduga** marriages is seldom associated with prolonged ceremony or major ritual procedures and **in** most cases it is distinctly secular. When an adult male and a female come together and start performing domestic activities and assist each other **in** other household affairs and agricultural activities, they are **said** to be married to each other. The husband will have access to the **wife's** sexuality and exercise right over the children born to her. Hence, marriage **is** a redistribution of female productive and reproductive powers which makes a new generation socially possible. For the Mudugas, marriage not only makes for the gratification of sexual desires, **but** also for the mutual co-operation and sharing of labour and food.

Bilateral cross-cousin marriage **is** the prescribed rule and there **is** no clear preference to either **patrilateral cross-cousin** or **matrilateral cross-cousin** and both are treated equal. Thus **it is** ideal for a man has to marry a female cross **relative who is in** the kin category *attiai* and a female has to marry a male cross relative **in the** category *machan*¹. People prefer to marry **with** families **with** whom there **is** previous kinship and previous **inter-marriages**. Their first choice **is** from amongst their **relatives**, and from **the** group where they have already established an alliance relationship. Marriage between the children of brother and sister, further consolidates the kinship between the two families and ensures an intimate and closer relationship between their members for their **life time**. The **kin** terms used to refer to the **sister's** children **in** the case of brother and brother's children **in** the case of sister are quite clearly indicate the presence of **bilatera cross-cousin** marriage. A woman refers her **brother's** son as *barmakan* (**son-in-law**) and **brother's** daughter as *barmaka* (**daughter-in-law**) **even** before their marriage. So also a brother refers to **his** sister's son as *barmakan* and sister's daughter as *barmaka*. **It is the** strong brother-sister sibling **bond** which plays an **important** role **in the contracting** of marriage **between cross-cousins**.

Parents of a boy always think that **if** their son is married to a girl who is from the circle of their already related **kin**, they will be assured of all **co-operation** and care by their **daughter-in-law**. **Moreover**, it is better for a **woman not** to **move** into a totally strange family or hamlet. If she is mamed to a genealogically close **cross-cousin**, **most** of the people **in** that family or hamlet will be familiar and **will** be related to her through several genealogical connections. **This** clearly shows that her **link** to them will not be merely an **affinal** one. Such an in-married woman **will** be seen not **only** as **daughter-in-law** but also as the close niece of **several** of their residents.

Right from the childhood, the **cross-cousins** are treated by relatives of both sides as potential spouses. It would often **bring** serious criticism **if** a person **marries** outside **his** km circle when he has a genealogically close **cross-cousin** or other close relative whom he could have mamed. However, due to various factors, **marriages** do not always occur between the real **cross-cousin** and it vanes **situationally** from real to **classificatory** cross-cousins depending on the genealogical knowledge. **Cross-cousin** marriage **is** the way b> which the links between the descent group could be **realised** and maintained **in** continuing alliance relationship **with** other **descent** groups.

Out of a total of 75 marriages recorded from **Thaze-Abbannoor**, 23 (26 **66%**) marriages were **with** real cross-cousins, and 29 (38 **66%**) **were with** classificatory cross-cousins. The data also shows that 12 (16%) marriages **were with the** category father's male cross-cousins daughter and 2. (2 **66%**) **with the** category mother's female cross-cousin's daughter (see table 6 **1**)

Table 6 1 Type of marriage

Type of marriages	Frequency	Percentage
FZD (real)	9	12.00
MBD (real)	11	14.66
FZD (classificatory)	15	20.00
MBD (classificatory)	14	18.66
F'FZS'D , F'MBS'D	7	9.33
F'FZS'D / F'MBS'D (class)	5	6.66
M'FZD'D / M'MBD'D	2	2.66
ZD (classificatory)	4	5.33
FZ (classificatory)	1	1.33
'MZ'	2	2.66
FZHZ	2	2.66
Female cross-cousin's daughter	1	1.33
Father's female cross-cousin	2	2.66
	Total 75	100

From **this it is** clear that a Mudugas not only prescribe bilateral **cross-cousin marriage** but also practice **it**. It **is** clear that they married cross cousins real or classificatory **in** 74% of unions **recorded** during **this** study. The remaining **16%** of marriages are cases of union in **which** the relationship **between the** spouses are not prescribed by the society as marriageable type.

Thus marriage takes place **with** related kin groups or families whose members know very clearly to **which kin** categories they all fall. **Moreover**, through the vertical and lateral extension of terminology itself **it** is evident **whether** they are **in** marriageable or non-marriageable category. Hence, the notion of descent group **and** the **knowledge** regarding **marriageability** and **non-marriageability** between descent groups are less important as far as Muduga marriage is concerned. **The kin** terminological system **itself**

clearly depicts the distinction between cross relatives with whom marriage is permitted and parallel relatives with whom marriage is prohibited- Hence the kin terminology is considered as a path leading towards marriage alliances.

Eventhough in certain cases when marriages are not between real or classificatory cross-cousins, the kinship terms used by members of both sides implies that the marriage has taken place between cross-cousin, i e., children of brother and sister. No separate terms are used for address in such situations, and the terms of address and terms of reference are the same. Thus the groom's father addresses his daughter-in-law's mother as 'sister' and the groom's mother addresses her daughter-in-law's father as 'brother'. This shows that cross-cousins are the most preferred mate and the rule of bilateral cross-cousin marriage is prescriptive at the ideological level.

A marriage union is regulated by TWO basic rules which operates in all marriages. These are the positive and negative marriage rules which demarcate, respectively, the unit of endogamy and the unit of exogamy. These are the limits within which an individual should marry as well as the categories of individuals he is prescribed to marry. The rule of exogamy prohibits marriage within one's own patrilineal descent group or kottam. The rule of endogamy is the requirement to marry within the larger unit, the community. Thus a person is permitted to enter in marriage only with a person belonging to the same community. The only exception to be noted here that the boundary of the endogamous unit extends to the neighbouring Kurumbas with whom there exist no marriage restrictions and who have similar patrilineal descent system. In practice the rule of exogamy, among the Mudugas, is not always determined by an apparent descent identity. The kinship terminology functions in categorizing its members, and these conceptual distinctions are used to express exogamic and endogamic rules.

The members of a descent group are considered to be structurally equivalent to siblings, parents, grand-parents, children and grand-children depending upon the generational differences. Since patrilineal parallel cousins or descent group members share the same blood, they are not permitted to enter in marriage relation. Cross-cousins are fundamentally different from parallel cousins. Because cross relatives do not share the same blood and possess different blood, they are considered as potential spouses and permitted to marry. However, matrilineal parallel cousins who are not of the same

descent group and **who** are not sharers of the same blood are prohibited from **marriage**. The prohibition of **matrilateral** parallel cousin **marriage**, unlike the prohibition of marriage between **patrilateral** parallel **cousins**, seems apparently **inconsistent** with the rule of clan **exogamy**. It makes sense only in the context of the **rule** of kin terminological extension and the equivalence of **same-sex** siblings.

Thus the equations, $FeBW = MeZ$ and $FyBW = MyZ$ clearly answer this **problem**. This equivalence rule depicted **in** the terminological paradigm of a **two-section** system reveals the rule of descent exogamy implicit in **it**. However, **it** cannot be concluded **that** the marriage custom and practice is based on or determined by the terminological **rules**. Rather, **it** should be understood that terminology **is only** the product of marriage customs and practices prevalent **in** a society and helps in aptly **depicting** the **rule** of marriage.

There **is** no specific **Muduga** term for incest. Marrying into a forbidden category **is** referred by saying "*muraihetti edukkirathu*", or they use the word "*thappu seyrathu*" which **is** also applied to wrong doing. However, the strict observance of prohibition of marriage **with** unmanageable categories apply to a restricted **extent** **1 c**, upto a circle of known relatives of ego. Beyond **this**, the rule restricting marriage **with** unmanageable categories **in** certain cases **is** transcended by **the tendency** to perpetuate the affinal links between the **two** groups even at the cost of contracting such marriages **which** according to the logical kin terminological extension seems **irregular**. In most **cases**, these types of unions fall **in** the terminological relationship of 'mother's brother*' - 'sister's daughter*' and 'sister's son - mother's sister*'. It is to be mentioned here that persons belonging to these two sets are cross **relatives** (either for ego or for **ego's agnatic** group) **even** though they belong to different **generations**.² The implicit purpose behind such unions being the intention to continue the relationship of affinity already existing **between** the two families or kin groups.

Wrong marital unions **between** persons who recognise relationship **in** stipulated kinship categories pose inescapable **quandaries**, for prior classifications **always** conflict **with** those created by such marriages. Marriages to **relatives known** to be related **in** the wrong **way** is very troublesome to the implementation of kinship classifications. Thus methods of terminological adjustments are established as rules for **kin** marriages **that** are wrong from the **perspective** of the **terminology** but which society **nevertheless permits**.

Case 2. Chellan's son Panali of Thaze-Abbannoor had married his mother's father's brother's daughter Kuppe. Thus Kuppe is in the category 'mother's sister' for Panali. However, since Kuppe's brother Velli had married Chellan's brother's daughter, Panali and Velli are in the category brother-in-laws and could marry brother-in-law's sister.

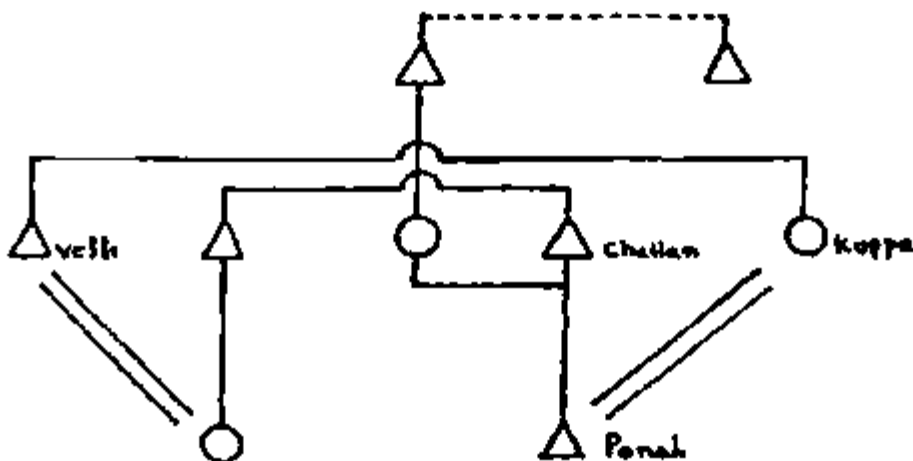

Fig 6 2 Genealogy showing relationship between Panah and Kuppe

Case 3 At Thaze-Abbannoor, Kakki's wife Neeli's younger sister Vanji has been married by Kakki's son Bokken (Bokken is borne for Kakki's first wife Vellachi) Here in this case, Bokken has married a woman who is in the category 'mother's sister'

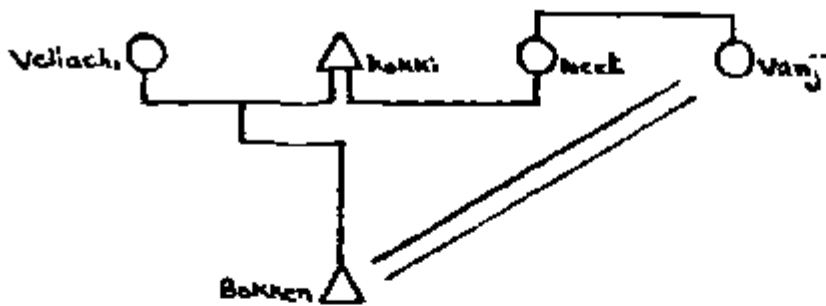

Fig 6 3 Genealogy showing relationship **between** Bokken and Vanji

Case 4 In another case from **Thaze-Abbannoor**, **Manji's** son **Kakki** married his father's sister's husband's (Kaden) younger sister **Barme** from Thaze-Thodukki hamlet Kaden is in the category *maman* for Kakki and hence *maman's* sister is *sinnauvai* (mother's younger sister) for Kakki

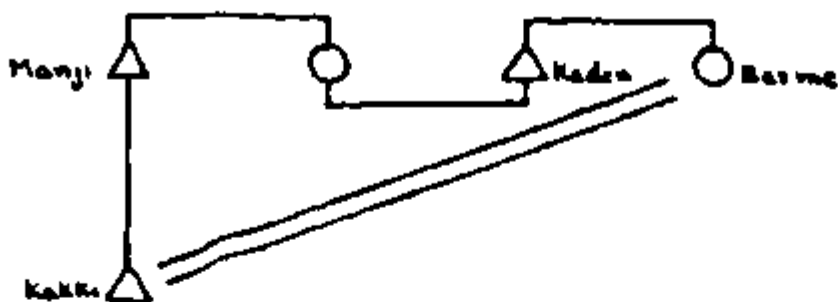

Fig 6 4 Genealogy showing relationship **between** Kakki and Barme

Case 5. At Veettiyoor, Chinnayan's father's sister's son Ponnann had married Chinnayan's daughter Chelli. For Ponnann, Chinnayan is in the *machan* (father's sister's son) category. Thus Chelli is mamed to her father's brother-in-law who is *maman* for her. This marriage falls into the MB-ZD type.

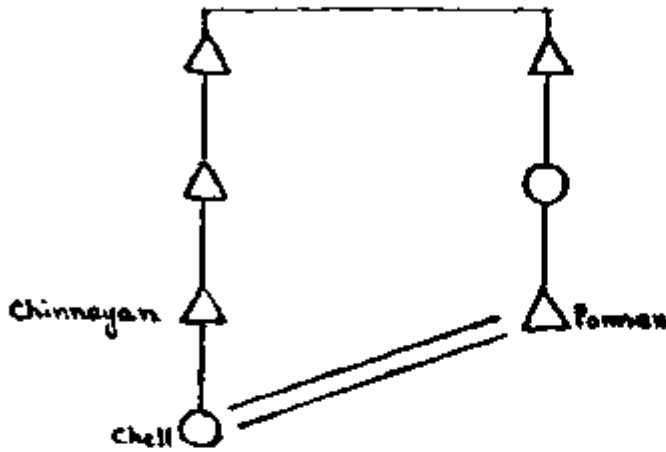

Fig.6 5. Genealogy showing relationship between Chelli and Ponnann

From the above cases it is evident that most of the 'wrong marriages' are of the type MB - ZD and MZ - ZS. It is noted that mother's sister and sister's daughter are not members of ego's descent group and fall in the cross category. Thus as long as these women need not always fit into a category of people that ego cannot marry, they are possible marriage partners (i.e., cross relatives) though of different generation to ego.

Even if the union is of a prohibited category, the husband-wife relation will be recognised, provided that the couple openly co-operate in the household affairs, child rearing, and in agricultural activities. Thus the status of husband and wife is dependent on a pattern of interaction between the two. It is the details of domestic interaction

between the two that **people** count as evidence of their **marital** status — whether the **man** clears field for her and **whether** she cultivates the **land**, cook and **serve** food for **him**.

There **is** no sexual freedom **prior** to marriage. **Even** though **love** making occurs among them, it is not supposed to **lead** to sexual intercourse. The love relationship is **likely** to develop **into** marriage if they are in marriageable category.

If a particular marriage union proves to be satisfactory, more marriages are likely to follow **between** the two **kin** groups in future. Marriage, thus in a **way**, is used as a mechanism to reinforce the earlier existing kinship links. Once an alliance relationship is established between two groups, **it** continues and is transferred from generation to generation as an enduring process and the ongoing movement **between** descent groups depends on the strength of the alliance. Every marriage must be reciprocated. One marriage reciprocates another so that each descent group both gives and receives a woman. The failure to return a woman disrupts the quality of the **relationship**. **This give and take** relationship between the two groups need not **always** occur simultaneously **in** the same generation. Reciprocity may be immediate **in** the form of exchange of sisters, or a woman given **in** one generation **will** be reciprocated **few** generations after.

The **patrilineal** segment of a descent group **will** be maintaining a consistent affinal transactions of the exchange of women between the patrilineal segment of another descent group. Once alliance **is** established, **they** do not want to cut off the links, but **to** maintain the exchange relationship enduring through generations. The alliance which **is** established between two families **will** be extended to other closely related families of the descent group. Thus there **is** a strong tendency to repeat the kin marriages between **agnatic** segments of two descent groups which creates an **obligation** to 'give and take' of **women** which to an extent restricts the choice **in all** subsequent transactions. **The following** cases depicts the continuous transactions of women **between** agnatic segments of two patrilineal descent groups.

Case 1. **Kali** of Thaze-Abbannoor belonging to **Manchipattai kulu** married **Mallan's** father's sister from Boodar hamlet. **In** the next **generation**, **Kali's** son **Mandi** married **Mallan's** daughter and again **in** the subsequent **generation**, **Mandi's** son **Kali** married **Mallan's** daughter and **Mandi's** daughter **was** given for **Mallan's** son **Chekidan**. **In** the next **generation**, **Chekidan's** son **Bam** married **Kali's** daughter **Nanji** and **Chekidan's**

daughter has been given for **Mandi's** son's son Panali. Mandi's **classificatory** brother's daughter had named Mallan's brother's son Panali and **Panali's** daughter Mallika was given to **Mandi's** grandson Kaden.

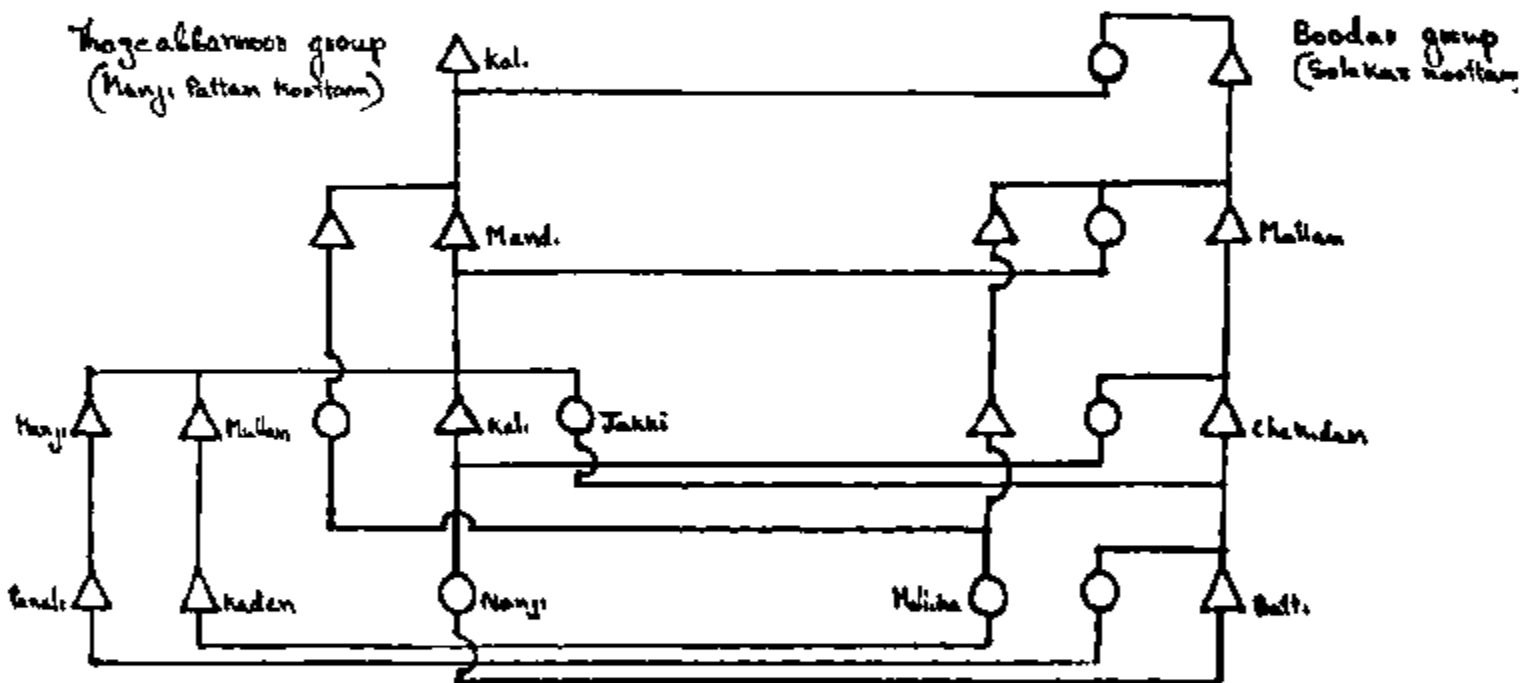

Fig 6 6 Alliance relationship **between** the patrilineal segments of **Thaze-Abbannoor** and **Boodar**.

Case 2 Budde of Thaze-Abbannoor **married** Thenkan's daughter Rangî from Veettiyoor and Budde's classificatory younger 'brother' Ooshi married Thenkan's younger brother Mathan's daughter Mallî. Budde's sister Kade **was** married to her mother's classificatory brother's son Budde* of Vettiyoor. **Budde's** and **Ooshi's classificatory** sister Meddi **was** given to Mathan's son Velli and **Velli's** daughter was married to Budde's younger brother's son Mathan. In the next **generation**, Budde's son **Kakki** married his **MBD** Neeli from Veettiyoor and **Kakki's** son Bokken married **Neeli's** younger sister Vanji-**Kakki's** classificatory brother's (**Kaden**) daughter was given to **Neeli's** brother's son. Budde's classificatory brother's son Manchi has married **Neeli's** father's classificatory brother's daughter

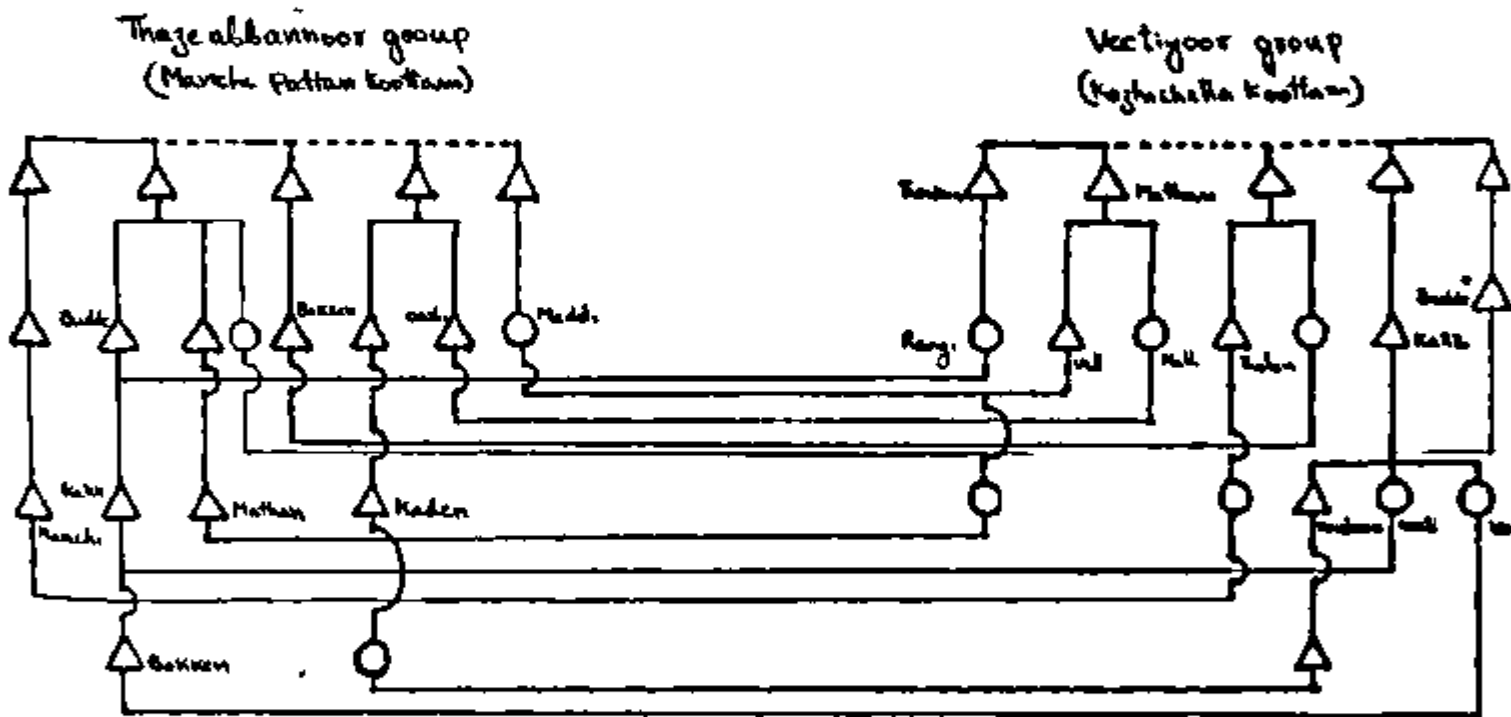

Fig 6 7 Alliance relationship between the patrilineal segments of Thaze-Abbannoor and Veettiyoor.

Case 3 The patrihneal descent group of **Karuvara** hamlet has been maintaining a consistent marital exchange with the **agnatic** segment of Thaze-Abbannoor continuing through generations. From **Karuvara hamlet**, **Neelan's brother's** daughter **Badigi** had been married to **Velli** of **Thaze-Abbannoor**. In the next **generation**, Neelan's son Chellan married Thaze-Abbannoor. Budde's daughter **Rami** from **Thaze-Abbannoor**, and Budde's son **Kakki** married Neelan's daughter **Vellachi**. Budde's '**brother**' **Bokken's** daughter **Malli** was given to **Neelan's** second son **Chathan**. The youngest son **Neelan** mamed Budde's **classificatory** brother's (**Mathan**) daughter and Neelan's son married Budde's brother's (**Velli**) grand son's (**Mathan**) son **Linkan**. **Chathan's** elder brother **Kanmen's** son **Vella** marned **Velli's** classificatory sister **Vellachi**. **Kanmen's** daughter **Neeli** was given to Budde's brother's (**Ooshi**) son **Velli**, and **Neeli's** younger sister to Budde's **classificatory** brother **Choken's** son **Man**

Chathan's daughter **Vellachi** was mamed to Budde's **classificatory** brother's (**Kiliyan**) son **Kakkilinkan**, and younger daughter **Kanmi** to **Ooshi's** brother's son **Ramaswami**. Chathan's brother's (**Chellan**) daughter **Mari** was given to **Velli's** son **Kali** and Chellan's another daughter to **Velli's** elder brother's (**Mallan**) son **Enyan**. Chellan's son **Pariah** marned **Ooshi's** daughter **Kuppe** who was earlier **marned to** Chellan's* brother's son **Nanjan**. **Panah's** younger brother **Murugan** mamed **his** mother's brother's, (**Kakki**) daughter

Karuvara Neelan's father's classificatory brother **Naiacchan** had first mamed **Mathan's** (Budde's **classificatory** brother) sister and later mamed **Budde's** brother's (**Kuruli**) daughter for Thaze-Abbannoor

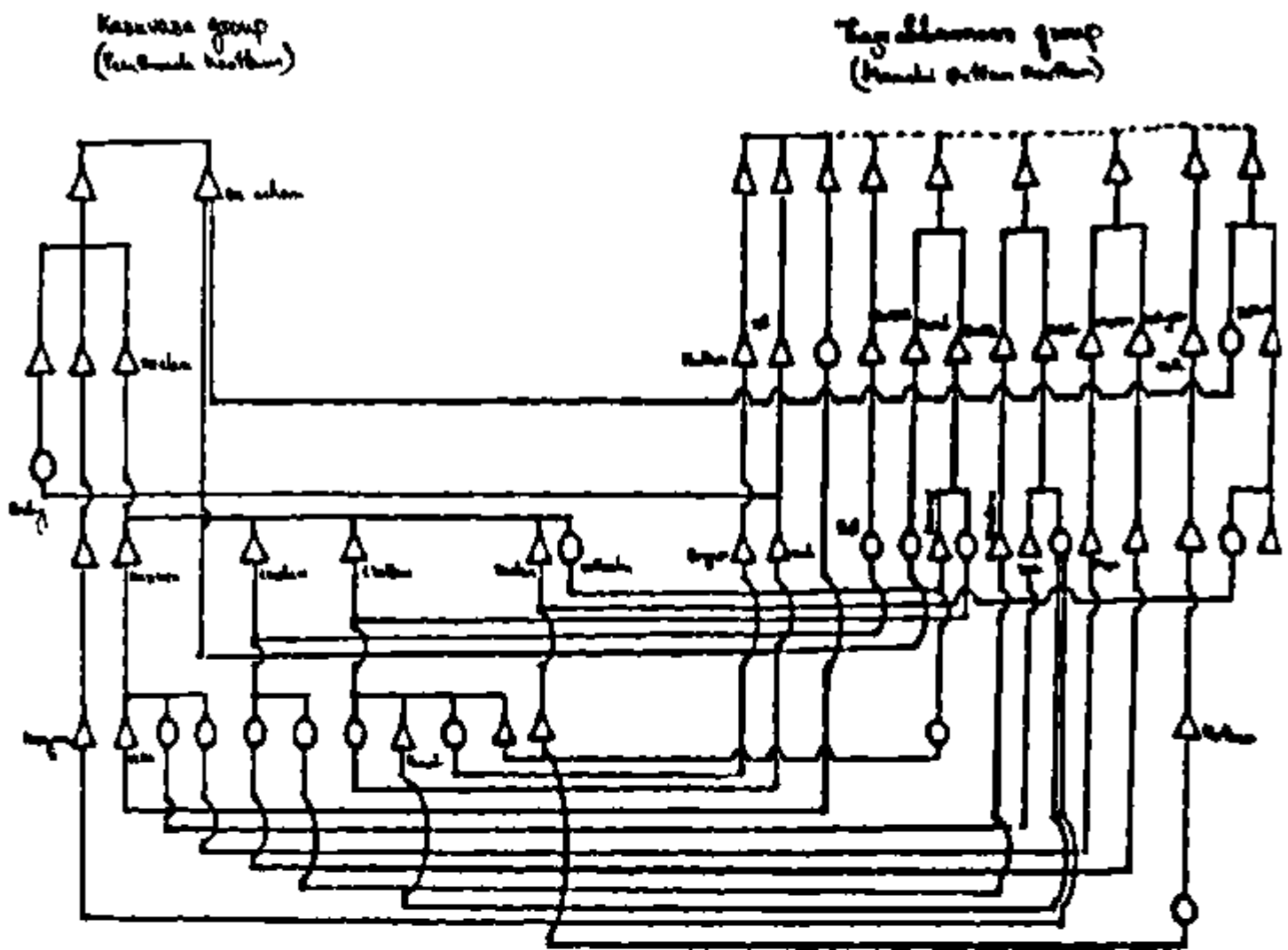

Fig 6 8 Alliance relationship between the patrilineal segments of Thaze-Abbannoor and Karuvara

Although marriage involves the 'give and take' relationship between two descent groups, the marriage exchanges cannot be treated as a relationship involving and depending on exclusively two descent groups. It is significant to note that the rule of kin categories and terminological extension defines the nature of relationship (i.e.

marriageable or unmarriageable) with other descent groups of the endocarnous community not previously related, by establishing links through related groups, and serves to continue the alliance relationship.

As already mentioned among the Mudugas, marriage exchange takes place with whom there exist previous kinship and previous **inter-marriages**. **However**, if they are not **aware** of the nature of relationship **they will** try to find out and be assured about the category **into** which they fall by tracing the relationship through the rule of kin terminological extension. The rule stating **'affine's affines** as kin* and **its** corollaries form the underlying principle through which the extension of the **kin** categories **is worked** out. Thus when **'A'** of **'P'** descent group enter **in marital** union **with B'** of **'Q'** descent group, **it** ensures that any two members of these descent group can enter **in** marriage relationship. The relationship may be extended vertically or laterally through the already related affines or **affine's affines**. Thus **if 'B'** had a **brother 'C', who** married a female **'D'** belonging to the descent group **'R'**, then a marriage between a member of **'P'** and a member of **'R'** cannot be legally permitted since according to the rule of terminological extension, members of **'R'** are **affine's, affine i e, kin** for **'P'**. The nature of **this** alliance relationship can be clearly explained by citing **case** from **Thaze-Abbannoor**

Thaze-Abbannoor *Manchi puttan kootam* **is** having continuous alliance relationship over generations **with** Karuvara *Paruthimala kootam* and also **with** Veetiyoor *Kozhichella kootam* (discussed above). Thus for karuvara *Paruthimala kootam*, Veetiyoor *Kozhichella kootam* are parallel relatives and are prohibited from marital exchanges since they are related as **'affine's affine'**. The elder and younger sisters of **Tholan** of *Kozhichella kootam* was **married** by Kumaran of Veetiyoor *Vandichindan kootam* and **Bokken** of Thaze-Abbannoor *Manchiputtan kootam* **respectively**. Since Thaze-Abbannoor *kootam* **is maintaining** affinal relationship **with** *Kozhichella kootam*, for them *Vandichindan kootam* **is** related as **affine's affine i e** parallel relatives. Moreover, **this** parallel relationship **is proved** when **Kakki** of Thaze-Abbannoor married **Neeli who was** earlier married by **Lacchi** of *Vandichindan kootam*. For Karuvara *Paruthimala kootam*, *Vandichindan kootam* is related as their 'cross relative's parallel relative's and hence treated as cross relatives. Thus Lacchi's son Raju of *Vandichindan kootam* has married Chathan's daughter of *Paruthimala kootam*

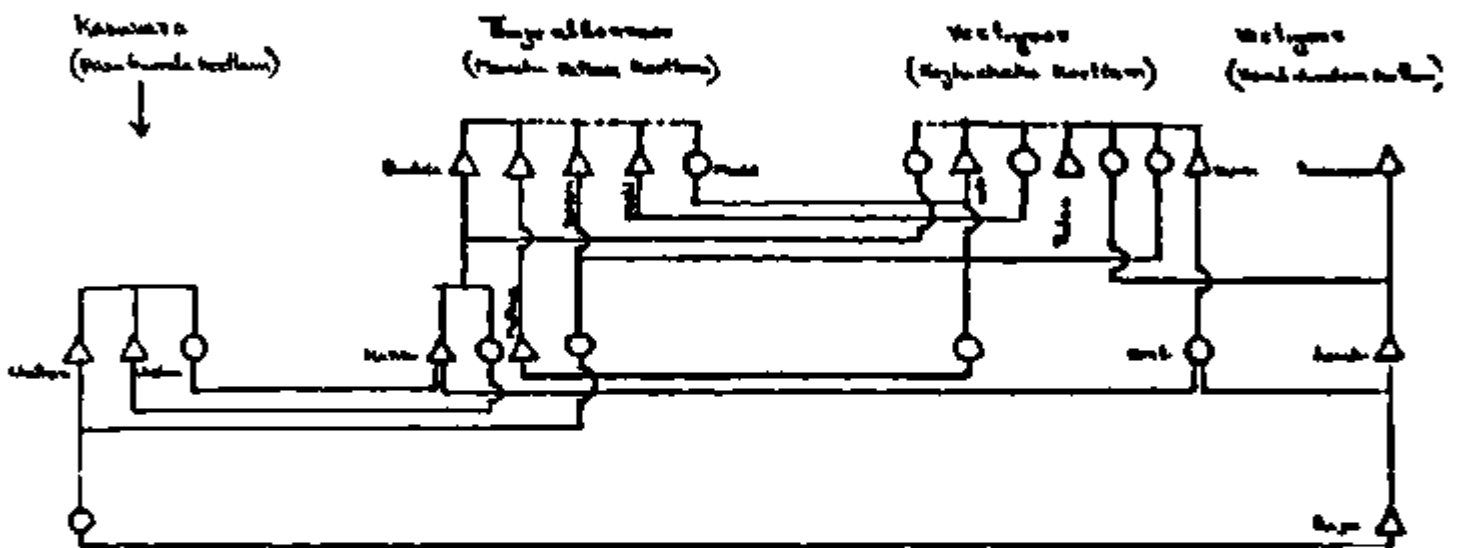

Fig 6 9 Alliance relationship between patrilineal segments of Karuvara, Thaze-Abbannoor and Veetiyoor hamlet.

A great deal of mutual assistance and support **do takes** place **between closely** related kinsmen and **are** deeply obliged to each other. Descent **groups** that interact **with** each other and **co-operate** more frequently and share land tend to continue **the** alliance.

relationship and exchange w omen- **Thus the** common residence and the **sharing** of land **between** affinal groups **will lead** to frequent intermarriages **between** the **two** groups.

However, **it is** to be mentioned here **that**, more number of marriages take place between members of outside **hamlets**. Alliance relationship and the marriage exchanges make for the movement of females from one group to another and functions in the reproduction of clan. However, agnation **functions** in the formation of the clan. People say that, **it is** women who are used to establish new relationship with the descent groups of other hamlets through alliance created by their exchange. Through these **exchange, a** network of relationship **is** developed with other hamlets. Thus they consider women as the “**path**” for new relationship and through exchange **women** go around and establish link **with** other hamlets. Once a new alliance is established **with** an **ooru**, the **>** **will** try to keep the relationship enduring through repeated ‘**give and take**’. The people refer to **this** enduring exchange relationship when they say, “*kontum koduthum bantham ottichu pokirathu*”, which means that through repeated **give** and take the affinal relationship **is** properly linked and maintained through **generations**. They never want to break **the** already established **link with** a kin group, and through repeated exchange, the relationship become more strong and cemented.

While speaking about the **cohesiveness** and solidarity of the system derived by the continuous marital exchanges between groups, the Mudugas always try to equate **it with** the structure of a broom (*kalamaru*). The **Muduga** broom consists of **two** main bundles of dry **twigs** closely **tied** together. While making a broom **it will** be **tied** **twice** **such that** the first tying divides the entire twigs **into** two bundles and through the second **tying**, half of the twigs from **each** bundles **will** be separated and **tied** together thus **dividing** the broom **into** **two** bundles. According to the Mudugas, **this** **mechanism** of exchange of twigs between the bundles holds them tightly together making **it** a strong and **cohesive** structure. **Similarly**, the exchange relations or ‘**give and take**’ between **two** groups ensures a net work of strong bonding between **them** **giving** **rise** to a **well** structured **system** binding **them** tightly together. They refer to **this** **by** **saying**, “*kontum koduthum emma ichu bantham kettumurukrathu*”, meaning “**through** repeated ‘**give** and **take**’ **we** make our relationship more **tight**”.

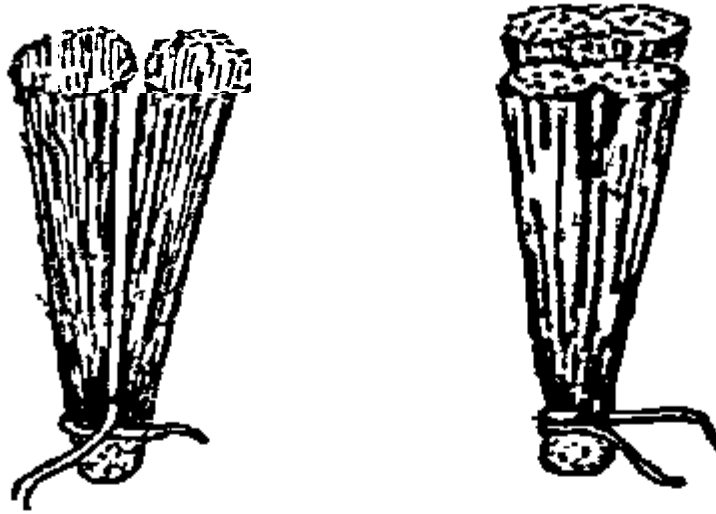

Fig 6 10 Tying of broom, analogous to marital exchange.

Thus every hamlet or its descent group will establish a set of exchange link with all other descent groups who are in affinal relationship. Affines who have taken women from a particular hamlet or its descent group are known as the *mappila* for that hamlet. Their obligation towards their wife's agnates is clearly evident at the time of ancestral festivals and other ceremonial occasions. *Thalaimappila* is the senior most affine who has married the senior most women of the senior generation of a particular kin group or hamlet. This *thalaimappila* will be having greater obligation and duty to perform at the time of *seeru* festival. It is he who has to look after the cooking and serving of food for all who have assembled in the hamlet for the festival. He will be assisted by other in-laws (*mappila*) of that *ooru* who is 'younger' to him. Thus for Thaze-Abbannoor hamlet, Rangan of Thundoor hamlet who has married Kilyan's elder sister of Thaze-Abbannoor is the *thalaimapila* for the hamlet.

The descent group functions as the unit of alliance and reciprocity. However, the kin unit consisting of closely related agnatic members is the most active unit in marriages transferring women, bride-price, and any counter-prestations on behalf of the descent group as a whole. Thus the constituent close kin circle forms the focus around which the various activities operate and function as the operational units which drive the marriage relationships. Lipuma, while writing on the Marang marriage exchanges, depicts the people's notion, "a clan bears 'the name of the relationship' and stands 'together in marriage exchange' while the subclan develops the 'give and take of the relationship'"

and he says, "it is the subclan which conducts the marriage negotiations, arranges the exchange and compensation and generally sets events in motion" (1988 : 152).

Even though the actual operation of alliance and the attendant exchange of gifts and prestations is confined to the immediate families, the ideal structure around which the implications of a particular marriage devolves is the descent group. Marriage alliance is organized and observed at the level of the patrilineal descent group — *koottam*. It is not the immediate members of the family who is taking a girl or giving a girl to another group. It is the *koottam* as a whole functioning as a unit which enters in this transaction. Marriage relation will bring the continuous flow of gifts, prestations and counter prestations between the two linked groups. Bride-price and all other associated compensation are raised from contributions from all members of the wife-taker's group and distributed to the wife-giver's group. In the *panchayath* meeting where bride-price payment is made, the girl is handed over by the descent group through the *jathi* (third-man) to the *jathi* of the other group, and the bride-price is also received by the *jathi* on behalf of wife-giver's *koottam* from the *jathi* of the wife-taker's group. Thus this is seen as a transaction taking place at the level of the descent group. A woman who has been married into a group belongs to the *koottam* as a whole since all members have contributed to the bride-price payment and hence the children belongs to the descent group. However, it is to be mentioned here that, though the descent group as a whole holds primary right in its female, the major share of the bride price goes to her father or brother and other immediate agnates.

Among the *Mudugas*, a boy is ready for marriage when he is grown up and matured enough to manage the farmland work and other activities done by men such as hunting, cutting bamboo from forest, collection of honey, and doing labour work to earn for the household expenditure. A girl is considered to be ready for marriage after puberty. By this time she will be capable enough to look after the household responsibilities and well acquainted with agricultural activities. On the basis of the household survey, the average age of a girl at the time of her marriage is 16 years, and that of a boy is 20 years. The number of unmarried girls above the age of 16 in the ten hamlets where household survey was conducted were 17, and out of this only three were above the age 20. The number of unmarried boys above the age of 20 were 10.

Among the **Mudugas**, proposal for a marriage are initiated by **the** boy's family, marked by the **involvement** of his **parents**, elder **siblings**, father's brothers and **other** elders of the close **kin** circle. **It** is considered degrading on **the** pan of the girls **family** to initiate a proposal.

In case of marriage taking place within the close network of **relatives**, the parents of the boy and **girl** agree to the marriage of their children **when** they are quite **young**. The formal negotiations are dispensed with and the settlement of marriage is relatively a simple affair. **This** type of marriage with immediate **cross-cousins** implies the transfer of alliance relationship established **between** the descent groups **in** the past **generation** and also shows that the immediate **kin** circles representing these **two** groups have already given assent to their consent. In such **cases**, the boy and the **girl who** are immediate cross-cousins are potential spouses to each other and once they reach maturity, they can start their family **life**. No ritual or ceremony marks **this** change of **status**. **What is** happening here **is** that, past marriage transactions may be reflected **in subsequent** generations as an attempt to renew the alliance relationship. But **if** the spouses are residing **in** separate hamlets and marriage ceremony **is** to be **held**, the negotiations are formally conducted and proposal **is always** made, and the **details** are **worked out between** the households concerned **in** presence of elderly relatives of the hamlet. **The** discussions and decisions **will** be made by **the** most important members of **the** close **kin** circle **like** grandfather, father, father's **brothers, etc.**, belonging to both **the** groups

Through marriage, a man exercise **rights in** a woman's labour power and reproductive capacities to **live in** a way befitting a dignified man. Their **co-operation** and sharing of labour on the farm feeds them and their children. The **union** sets up an economic partnership between husband and **wife in** which each **has** extensive rights and obligations **with** respect to the other. The process of acquiring a **wife is essentially** a secular **one, involving** the physical transfer of the woman to her **husband's** group. **If the** marriage **is to persist**, she must be successfully retained so **that** she forms a sexual and economic partnership **with** the man and eventually bear children **who** inherit **his** *stilus* as descent group member. There **is** no precise point **at which** the marriage **is established**, but the likelihood of it lasting depends upon two **main factors** — the acceptance of the **situation by the** kinsmen and **the birth** of children.

For a **marriage**, prior to the proposal making and formal negotiations, the relevant **line** of inquiry may be whether the woman is **hard-working, healthy** and able to lead a stable family **life** and also whether she is faithful. **Similarly**, the **girl's relatives** will also collect information regarding whether the man is **hardworking**, shows concern for his **wife**, and take responsibility of the household expenditure. **However**, the most important inquiry is that whether there exist a "**marriageability**" or "**marriageable *marai***" between the two families.

Marriage negotiation do not break on **matters** connected **with bride-price, because bride-price** payments do not always form a major item in the initial stage of marriage relation. It only occurs **in** a later phase of their married life particularly in **the** case when no marriage ceremony as such **is** held. Moreover, the payment **of *pariya-panam* (bride-price)** **is** not the sole responsibility of the immediate family members, but the descent group members collect together and contribute to **it**. Hence, the amount of **bride-price is** not at all an issue during the negotiations.

Regarding marriage special preference **will be given** to members who are residing nearby **in** the same hamlet **with whom they have** frequent interaction. Members of different descent groups who occupy **the** same hamlet and **in** close proximity have more interaction and they **co-operate in** economic **activities**, share land and other resources. **This** makes them enter **in alliance** relation through the exchange of women or to **renew** the already existing alliance relation through **generation**.

However, people also prefer to establish alliance relationship **with their** close relatives **in** other hamlets so as to establish new **line** of **interaction**. **With** them there always exist a warm and polite relationship since **they are not in** frequent contact. Moreover, they say that, since the spouse's hamlets are **away**, they can **make** formal **visits** to their **in-law's** huts **where** they **will** be **welcomed with** more concern and respect and **will** also be presented **with** plenty of gifts from **the** related huts. **This** formal **visit is not** possible when marriages are taking place **within the** same hamlet.

Whenever Mudugas go for **marital** relation **with** a **new group**, they **will not only** be concerned **with** the immediate **family**, but **will look into** the number of closely **related** families and see how big **is** their kin circle and familial **connections**. They **say that, if** there are more number of closely related **families**, then **the newly married couple could**

lead a secure life and seek help and co-operation from these related families when they are in need. This nature of their alliance relation is very well depicted by them through the analogy of a tuberous climber called *saval-valli* (*Dioscorea* species). According to them, whenever they are in search of tubers, they select to dig out the base of a plant which is often having more than three strings (*valli*). They will not usually dig the base which is having just one string, since tubers will be very few under it, and the entire labour of digging will be a waste. They are very much sure that, if they dig the base which is having three or more strings, they can get sufficient quantity of tubers. Even if one or two strings do not produce tubers at its base, the others will produce sufficient number of tubers. Similarly, in the case of marriage, Mudugas prefer to have alliance relationship with families who are having quite a large circle of kinsmen and closely related families. This will ensure the stability of family life of the new couples and will have many related families and kinsmen to extend support and cooperation whenever needed.

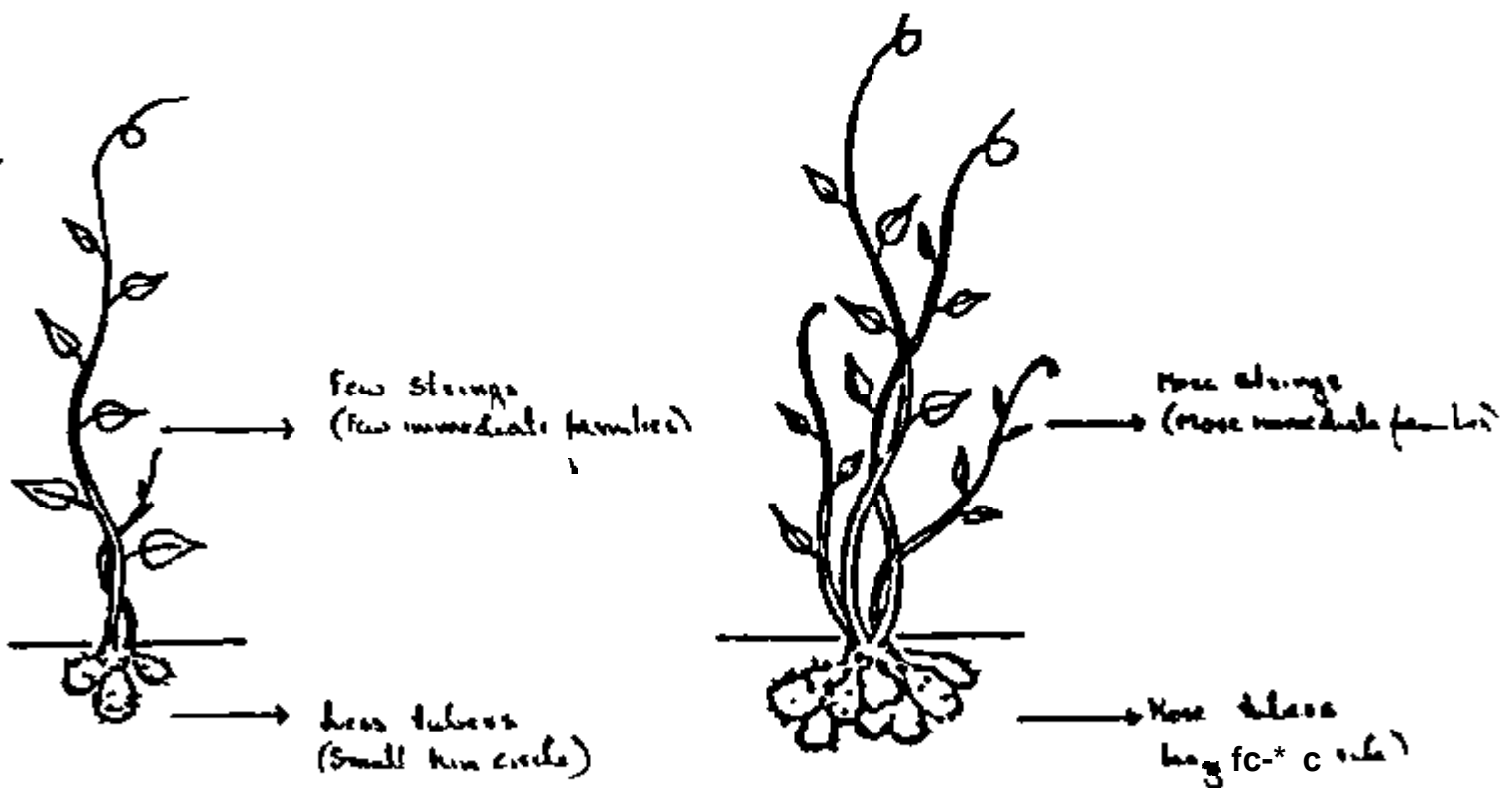

Fig 6.11 Analogy of Saval plant and family relations

Mudugas are monogamous in the sense that every person keeps only one partner at a time and instances of both polyandry and polygyny are absent. Similarly cases of sororate and levirate marriages are noticed very rarely. However, divorce and remarriages of both partners have always been observed among the Mudugas.

Marriage pattern and procedure :

Unlike the traditional form of Muduga marital union which is devoid of marriage ceremony, nowadays marriages are accompanied by formal rituals, ceremonies, and feasts. A suitable girl from a known and acceptable kin group having been determined, the parents of the boy make a formal proposal through a close relative to the girl's parents. After that, the boy's parents and close agnates visit the girl's house with one or two elderly members of the hamlet, usually *bandari* or *kuruthala* as third men (*moonathavan/ jathi*). The bride's group will not agree to the proposal immediately, instead they reply that opinion regarding this will be informed later after consulting their close relatives.

The responsible elders of the girl's hamlet like *moopan*, *kuruthala* and *bandan* are kept informed about the proposal. The final decision for the acceptance of the proposal rests with the girl's parents and close agnates, though other elder members in the hamlet are consulted and suggestions sought. Later, from the girl's house, her parents and one or two close relatives visit groom's house to see the groom. Meanwhile, in the girl's hamlet, the proposed girl's age-mates will get to know her opinion whether she is willing for this alliance. When the proposal has been accepted, the boy's close agnates along with *moopan*, *bandan* or *kuruthala* of the boy's hamlet goes to the girl's house to fix the marriage date. Though the final decision in a marriage negotiation vests with the immediate family, the close agnatic kin and the hamlet members (*oorutarar*) are nonetheless seen to be participating in the various stages of discussion to clinch the alliance. Leach thus while writing about the Kachins, very aptly says "the corporate group of persons who have the most decisive say in bringing about an arranged marriage is always a group of coresident males" (1961 - 56).

On the fixed Sunday³ afternoon, the boy's parents with a group of relatives along with the elders of the hamlet like *moopan* and *bandari* or *kuruthala* as third man visit the

bnde's hamlet, where they will be given a warm welcome. The groom's party which stays overnight is given high hospitality by the bride's people. Food will be prepared and is served for all the people who have assembled there and other members of the hamlet. On the following day, i.e., on Monday, the groom's party moves back to their hamlet along with the bride and her relatives. This event of bringing of bnde to the groom's hamlet is called as *pennukootti barunthathu*.

After reaching the groom's hamlet, the bride goes to the priest-house (*per kooru*) and offers prayer. An important ceremonial act of the bnde after reaching the groom's hamlet is to fetch water from the nearby stream. The bnde after offering prayer, goes and fetch a pot of water from the stream for her mother-in-law. The groom's sister (*attai*) accompanies the bnde when she goes to fetch water. This ceremony known as *thannikku pokirathu* (fetching of water) symbolises the transfer of her Labour potential from her natal household to the one where she will live henceforth for her life.

The bnde's party stays overnight at the groom's hamlet. Food will be prepared in the groom's hut and is distributed to all the people present and other members of the hamlet. On the next day, i.e., on Tuesday after the feasting is over, the major part of the marriage ceremony - the bride-price giving (*pariya-panam kettirathu*), is held. The *pariya-panam* is collected through a *panchayath* consisting of the hamlet's council members and other elder members of both the party. The groom's father first keeps an 'initial amount' in the *panchayath*. This is called the *muthal panam*. After that all the relatives of the groom especially his agnates who have gathered there contribute money depending on their ability towards the bride-price. From this money, an amount is earmarked as *pariya-panam* by the *panchayath*. The bnde-groom's *jathi* takes the bride-price from the *panchayath* and hands it over to the bnde's *jathi*. The bnde's *jathi* gives the amount to the bnde and she finally presents it to her father. The remaining money is distributed equally among the *panchayath* members.

In a later stage, the bnde's relatives will give cattle or goats, vessels and other household utensils etc., as counter prestation to the groom's household which is known as *seedhanam*. It is significant to note that only a cow or female goats are presented as *seedhanam*, since it gives birth to young ones and keep multiplying, and the couple can

lead a comfortable life depending on them- This female cattle represents the **nucicus** for a future herd.

After about one **week**, on a Monday, the bride and the groom make their first visit to the **bride's** hut. They take with them the goods **given** by **the** groom's parents as gift to the **bride's** parents. These goods include ten liters of rice and other household provisions like **coconut, onion, dhal, coriander, chilly, etc.** The couple stay in the **bride's** hamlet for about one week. Food prepared out of the provisions brought by them **is** distributed to their relatives in the hamlet. During their stay in the **bride's** hamlet, the couple **will** be send together to work in their farmland and one or two days later close relatives **will** visit the field where they are working so as to see the groom's ability to work in the field-

When the couple returns to the **groom's** house, the **bride's** father also send with his daughter the same amount of goods as gifts for the groom's parents with which a counter feast **is** given to the relatives in the **groom's** hamlet. To emphasize the new union between the two families, a long series of visits by the **newly married** couple accompanied by gifts alternating **between** the groom's hamlet and **the bride's** take place. The chain of gifts that are **exchanged**, as Dumont says, symbolizes the alliance **tie** which constitute the most important feature of **mamage** ceremonies from the point of view of the relation **between** the two families (Dumont : 1957)

During the initial phase of the **mamage**, the boy and the **girl** **is** obliged to spend more time in the **bride's** place working in his **parents-in-law's** farmland and assisting them in other economic activities. After **this**, they permanently settle in the **groom's** hamlet and erect a new hut nearby his **parent's**, and start their independent household.

Two cases of **mamage** ceremonies **will** be presented here so as to clearly **bring** into picture the various rituals and events **occurring** during a formally held marriage ceremony. The first one is that of **Mani's** **mamage** at **Mele-Abbannoor** which is a typical case of **mamage** ceremony held **between** members of two different hamlets. The second is that of **Murugan's** **mamage** with **Pavashi** at **Thaze-Abbannoor** which is a case of **mamage** ceremony held **between** members of same hamlet.

Case 1. At **Mele-Abbannoor**, **Chekidan's** son **Mani's** **mamage** with his mother's brother's daughter from **Thadikundu oor** was held in the month of **March, 1997**. **Chekidan** and his wife had initiated the proposal few **years** back and soon the **consent** of

his wife's brother Mathan who had agreed to give his daughter in marriage to his sister's son.

On the proposed Sunday afternoon, the groom's parents with a group of relatives accompanied by the *bandari* of the hamlet as *jathi* went to the bride's hamlet. The groom's party was given a warm welcome and they stayed overnight in the bride's hamlet. Food was specially prepared and was served to all the people who have assembled there. On Monday afternoon the groom's party came back to their hamlet along with the bride and her relatives. This is called *pennu kootti barunthathu*. A *panthal* was erected in front of the groom's hut using bamboo and cas leaves. The bride's party stayed overnight at the groom's hamlet. Food was prepared in the groom's hut and was served to all the people who had gathered there. The bride took rest in the groom's hut and she was accompanied by her mother, sisters and also the groom's sister.

On Tuesday morning, the groom and the bride along with few other relatives went to the *mannukaran's* hut (*pet koorai*) and offered prayer to the *karudavam* (Since Chekidan and his close relatives were staying away from the main hamlet, this offering of prayer was not done on the previous day)

On Tuesday afternoon, food was served to the entire relatives who had gathered in the hamlet. After the feasting, the main event of the marriage ceremony, i.e., the *panchayath*, was held for the payment of bride-price (*pariva-panamkettirathu*). The main person heading the *panchayath* will be the *jathi* from the groom's side. Chekidan's sister's husband Ramaswami who is a resident of Mele-Abbannoor took the role of the groom's *jathi* (*aan-jathi*).⁴ The groom's *jathi* then spread a mat in the centre of the *panthal* in the east-west direction and kept Rs 100 as *dakshina* at the centre of the mat. Then the *moopan* and *mannukaran* of the hamlet, both the groom's and bride's father, and other elder members of both the party including the *jathi* of the bride's side (*pennu-jathi*) sat in a circle on the mat for the *pancha ark*. Before finishing for the *pancha ark*, the *mannukaran* has to keep Rs 100 and the *moopan* also should keep Rs 100 as the hamlet money (*ooru pathu kudipanam*). All the other relatives will gather around the *panchayath* so as to watch the proceedings and also to participate in it.

The groom's father then kept Rs 100 and after that a plate containing betel leaves, betel nuts, beads, and tobacco was also kept in the mat of the mat. He also

placed an amount of money as *pakkala panam*⁵ towards the bride-price. The groom's *jathi* will formally enquire the groom's and bride's party about the reason for the *panchayat*. After getting reply from the groom's father, the *jathi* asked the bride-price they are expecting. Discussions regarding the bride-price along with arguments and counter-arguments will carry on between the two parties headed by the groom's *jathi* symbolising the bride as cow and the groom as bull⁶

The main dialogues made in the *panchayat* while discussing on the *panya-panam* is as follows :

grooms *jathi* : *nimma eenku enthuku bantheru...?*

(why you have assembled here...?)

bride's party *emma ee oorukku maadu kootti bantheru...*

(we have come with a cow for your hamlet)

groom¹'s *jathi* *maadukku enna beta.. ?*

(what is the price of the cow)

bride's party *munnooru___*

(Three hundred)

groom's *jathi* *ithu banthu enna kanakku...?*

(on what basis it costs so much price ..?)

bride's party *thadikundilunallapullirikka athu thinthu maadu nalla koluthiru-akkum*

(at Thadikundu there are vast areas of thick grass lands eating this fresh green grass, the cow is fully grown up and it cost a lot)

groom's *jathi* *maadukku nalla paalirikkutha .?*

(whether the cow gives sufficient milk ..?)

bride's party *nalamaayi noodi meschu nalla pul kedakkum*

(If you care for it and feed them well, it gives good amount of milk)

Simultaneously with the discussion, the bride-price collection had started and the groom's *jathi* was seen inviting all the relatives who have gathered there to come and contribute an amount towards the bride-price. Contribution will be made not only by the agnates of the groom, but also by the affines. The *jathi* will call aloud, " *anna-thamp...macha-mama. pettapillai..come forward and keep your contribution*" The money was collected in three separate sets *-anna-thampipanam macha-mampipanam* and *petta-*

pillai panam. The agnates of the hamlet contributed money as *anna-thampipanam* and the affines made their contribution in the *macha-maman set*. The 'sisters' and 'daughters' of the hamlet who were married out placed their money in the *petta-pillai set*.

While the bride-price collection was going on, it was clearly evident that the agnates and the affines compete with each other in raising the contribution. The *jath* will keep on counting the amount so far collected in the two sets and will make the people enthusiastic and encourage for more contribution.

After the collection was over, the *macha-maman panam* and the *petta-pillai panam* was put together. The *pakkala panam* kept by the groom's father was added to the *anna-thampipanam* and this amount was used for the bride-price payment. The *jathi* then counted the full amount collected. Around Rs.350 was collected and Rs.251 V* was decided to be paid as *panya-panam*. Then the *pariya-panam* was taken by the groom's *jatfu*. and was handed over to the bride's *jathi* by saying; "this is the money of the *pallimakkal* (descendants of Palli ancestor)... do not think that we are giving only this, more will be given later."

Then the bride and the groom came and sat in the *panchayath*. The bride's *jathi* then gave the money to the bride saying, "*ithu ninnu panam . ithu banki mnu appanthu kaikkal kodu*" (this is your price, take it and give it to your father). She received the money and touched the feet of the *jathi* and gave the money to her father's hand and touched his feet. While receiving the money, tears came out from Mathan's eyes. After blessing his daughter by touching her forehead he uttered these words to her "*ithu ninnu pennu panam . ithu naanu bankire* (this is your bride-price, I am receiving this)

aanal nee intu muthal ninnu alanthu koode n nnu mami mamanthu koode nalamay irunthu kollu .

(from today onwards you should live peaceful!) with your husband, mother-in-law and father-in-law)

ninnu mamano mamayo atti a macha enthu son am en hu sandep Jitha n maranthu kalayadorn onnum nenjil bekkaruthu

(even if your *mami* *mami* *attiar* *macha* quarrels with you, please forget it do not keep it in your heart.)

..nee eenku nalamayi irikkadam (you should lead a good life here).

ithanyum naalu naan ninne nalamayi balarthine __Hi ninnu nadappu kaaranami enakko ennu oorukarkko cheetha peru barakooda`...

(till now I have looked after you well...now lead a good life and do not bring bad name to me or my hamlet).

After this, the groom's father also declared to the *panchayath* and others who have assembled there that he had given the **bride-price** for his son and assured that He will take care of the **girl** from then onwards. Then the bride was asked to pay **Rs.10 '4** to her mother's brother. She gave the money given by her father to her mother's brother and touched his feet. The groom also paid Rs 10 '4 to his mother's brother (who is also the bride's father) and Rs 2 V* to his father's sister's husband Ramaswami. By this, the marriage ritual was over and the *panchayath* came to an end, and all who sat for the *panchayath* got up after which the ritual of 'taking back the mat' was done. This is known as "*ezhu peru sollu edukkirathu*". For this, the bride's father and the groom's father kept Rs 1 V* each on the mat which shows that the *panchayath* is over and 'seven people' were witness for this *panchayath*. This money goes to the groom's *jathi* and he folds the mat.

The *macha-maman panam* and *pettu pillai panam* was distributed equally among all the members who sat for the *panchayath*. The remaining money was used for paying the *ooru panam*. This is a small amount given to any one member of other outside hamlet as a token for representing their hamlet in the marriage function. After the *pariya-panam* payment was over, the relatives gathered there for the marriage started dispersing, and the bride's relatives, except few, returned to their hamlet. With this the marriage ceremony came to an end.

Case 2 Thaze-Abbannoor, Chellan's son Marugan's marriage with Kakki's daughter Pavashi of the same settlement, who is also Murugan's MBD, was decided to be held in the last week of March, 1997. Few years back itself both the families have expressed their willingness and had reached an agreement to get Murugan and Pavashi married.

On the proposed Sunday, *pan hal* was erected in front of both the bride's and the groom's hut. Close relatives from nearby hamlet started reaching Thaze-Abbannoor by Sunday afternoon itself. On Sunday evening, food was prepared at the bride's hut and was distributed to the entire hamlet. Since it is the obligation and duty of the affines, the

cooking and serving of food was done by the affines of the bride's group who are residents of the hamlet. Thus the groom himself, his elder brother Panali, groom's father chellan, Kakki's classificatory sister's son Rangan, etc., worked as *mappilakal* for the bride's people. Since the bride and the groom were from the same hamlet, this symbolized the feast given for the groom's party who had arrived at the bride's hamlet to take her to the groom's hamlet. It is to be mentioned here that most of the *evexits* in the ceremony were enacted by the people to show that the marriage took place between members of two different hamlets.

On Monday afternoon, the *jathi* of the groom with a stick in one hand and holding an umbrella, along with two other relatives of the groom, proceeded from the groom's hut to the bride's hut. They enacted as if they came with a proposal and made a formal enquiry to the bride's parents for their daughter. The bride's parents did not agree to the proposal immediately and instead replied that their decision will be informed later. The groom's *jathi* again made a visit for the second time to the bride's hut to know their opinion regarding the proposal. At this time, the bride's parents and relatives expressed their willingness to give their daughter, but were not ready to tend their daughter with them that time. The groom's *jathi* returns to the groom's hut and informs them about the decision of the bride's relatives. The next time, the groom's *jathi* along with the groom, his parents and other relatives proceeded to the bride's hut. This visit symbolizes the going of groom's party to the bride's hamlet to bring the bride. The groom's relatives will be invited inside the bride's hut and a final agreement is reached.

The bride and the groom offered prayer to the *karuduvam* in the priest-house and after that they both got blessings from the bride's parents. The groom's party along with the bride and the bride's relatives then proceeded to the groom's hut. They made a long procession throughout the hamlet and reached the groom's hut where they were received with warm welcome. During the procession, the groom's brother-in-law (sister's husband) holds umbrella for the bride. The bride and the groom were invited to the inner room of the hut and they offered prayer to the *karuduvam*. This procession represents the event of *pennu kootu baruthathu* i.e., bringing the bride to the groom's hamlet. After this, food was served to all the people who have gathered for the marriage.

The affines of the groom's party, especially their son-in-laws actively engaged in the preparation and serving of food.

On Tuesday afternoon, *panchayath* meeting for arranging the bride-price payment, which is the major event of the marriage, was held. For this, the *bandan* of the hamlet (who did the role of groom's *jathi*) spread a mat in the *pandal* erected in front of the groom's hut. The mat was spread in the east-west direction and he placed Rs. 1 V* as *dakshina*. Then the groom's father placed his *dakshina* along with a plate containing betel leaves, betel nuts, tobacco, beedi, etc. After this, the *moopan* of the hamlet and other elder members sat for the *panchayath*. The *moopan* also placed Rs. 1 V# as *dakshma* on behalf of the hamlet. Then groom's father placed two *pakkala panam* hundred rupees each, in the *panchayath*, one for the groom's bride price and the other for groom's elder brother Panali's bride price. The bride's father also placed a *pakkala panam* to pay the bride-price of his earlier wife who is the mother of the bride. Since Pavashi's mother's *panya-panam* was not yet paid, Kakkai was not having the right to receive the *party a-panam* of his daughter.

Later, the *bandan* called aloud and invited all the relatives gathered there to come forward and contribute their share towards the *party a-panam*. *Macha mamanpanam* and *petta-pillaipanam* of both the groom and his brother was collected together. After the *panya-panam* collection was over, the *jathi* counted the entire money collected in the *panchayath*. An amount of Rs. 225 V* was earmarked as the *party-panam* for Kakkai's wife Chathi (Rs. 51 V* was earlier paid towards the *party-panam* of Chathi). The groom's *jathi* gave the money to the bride's *jathi* and he gave it to Chathi and the latter handed it over to her elder brother Kaden. Before receiving the *party-panam*, Chathi's brother placed Rs. 1 V* as *dakshina* to the *panchayath*. Then Pariah's wife was called to the *panchayath* and Rs. 225 V* was given to her by the *jathi* as her price. She then gave it to her father Ooshi. After this, Pavashi was called and Rs. 225 V* was given to her by the bride's *jathi* and she handed it over to her father Kakkai.

Thus in a single *panchayath*, three bride-price payments were made simultaneously. The remaining amount of money was distributed equally among the members who sat for the *panchayath*. *Ooru panam* was also given to relative* who

represented the outside **hamlet**. After the *panchayat*, food **was** served to **all** those who attended the marriage. This concludes the ceremonial aspect of **the marriage**.

Traditional **system** of marriage :

The **marriage** system practiced by the Mudugas in the **past** had a different procedure than what is being done now. In olden times among the **Mudugas**, marriage is usually marled by the absence of ceremonies or rituals. If a marital union **is** accompanied by formal **ritual, ceremonies, feast and bride-price payment**, then **it** can be called a **marriage ceremony** in the formal sense and the Mudugas refer to it as *kalyanam*. In traditional **context**, the Mudugas hardly employ a term for marriage ceremony as **such**. **The** often used term *pennu edukkirathu* (to take a **girl**) refers to the marriage union. Even **now-a-days** among the Mudugas, most marriages are devoid of major ceremonies and **rituals**. At Thaze-Abbannoor, out of a total of 75 marriages recorded **from** 45 couples and **18 widow / widower**, 70 marriage unions were held **without** any formal **ceremonies**, and only 5 unions were formally arranged **with** rituals and ceremonies accompanied by feasts and immediate **bride-price** payments

According to them, when a man and a **woman** starts **living** together and share their labour and **co-operate** in household **activities**, their **married life** starts **There is** no event which bridges pre-and post marriage statuses. **The** crucial elements are the pragmatic interplay between **duration, fertility, bride-price** payments and community recognition. Marriage crystallize as **time passes, children** and other indices accumulate **bride wealth is** given and the community recognizes **the** raarnagt **and the** couple so presents themselves to **the** community.

As the woman becomes **progressively** assimilated **into** the man's **family** and establishes herself as a **wife** and hard **worker**, the marriage begins to **crystallize**. Many years after the marriage, during any **occasion**, sometimes **at the time** of their children's **marriage** or at the **time** of **either** of the spouse's **funeral**, the **bride price will be paid**. Before the payment of **bride-price** itself the people **acknowledge** the union. **They** recognize **it** as a marriage. People recognize that a **couple may** be roamed **even if** bride price has **never** changed **hands**. **And, even if** bride price **is paid, it is** not until the couple **have** produced children **that** the raarnagt makes **root**. Thus **among** the **Mudugas, the**

purpose of bride-price is not mainly to legitimize the conjugal relation. Rather, it is the conjugal relation and the birth of the children which legitimizes payment of bride-price.

In olden days there was the custom of bride-service (*penru vela*) among the Mudugas. Marriage was by means of rendering service to the bride's parents. The boy, if accepted by the girl's father, had to offer service for him by working for about 2-4 years. This is a period during which a prospective groom provides labour service to the family of the bride in order to marry her.⁹ It usually involves a period of uxonlocal residence. There is a prior agreement between the two families, and when the boy reaches maturity and is capable of doing labour, he goes to the bride's parent (usually his MB or FZ) and reside along with them to work in their farm land and to assist them in other economic activities. In some cases, the boy should also do service for his parents-in-law's close kin residing nearby assisting them in their agricultural activities, and try to be in more cordial relation with them.

During this period, he stays along with the bride's parents in their hut and his prospective mother-in-law cooks food for him. But in a later stage, if he could win the consent of the girl and is willing to live with him, she starts accompanying him to the farm land and assist in agricultural activities. In due course, they both start living together and he erects a new hut nearby his wife's parent's and start an independent household staying uxonlocally. He clears separate field and both the husband and wife share their labour in cultivation. However, he continues to assist his wife's parents, maintain frequent interaction with their household, and share food with them. After a period of 3 or 4 years, he returns with his wife to his natal hamlet to live along with his agnates.

However, there are instances where the wife's father forces the son-in-law to reside in his hamlet and co-operate with them in their agricultural activities for a long period. Thus he continues to reside uxonlocally in his wife's hamlet as long as he receives co-operation from his affines. There are also instances where the bride's father if having large number of cattle's and other property or if he is having no sons to look after them, forces the son-in-law to reside in his hamlet taking care of his cattle and field and assisting in other activities for a period of time. Among the Mudugas, it is the privilege

of a father-in-law or a mother's brother to get any amount of service from their son-in-law / sister's son.

Case: Mandi of Thaze-Abbannoor had married Chellan's sister from Boodar hamlet. Later, Mandi's son Ooshi was proposed to marry his mother's brother's daughter from Boodar. Since his mother's brother Chellan kept plenty of cattle and had large farmland, he wanted his prospective son-in-law to stay along with him after marriage, and to take care of his cattle and the farm land. Chellan also assured that he will be given few cattle and also land for cultivation. But Ooshi could not agree to this demand since he had to look after his younger siblings and his aged mother. Even though both the families agreed for the marriage, Ooshi did not go and reside along with his mother's brother. Later, after few years when his younger brother Kali become matured, Ooshi forced him to marry Chellan's daughter. As instructed by his elder brother, Kali married Chellan's daughter and stayed uxori locally along with his mother's brother assisting him in agricultural and other economic activities

The custom of bride-service is not practiced as such among the Mudugas now-a-days as it was in olden days. However, traces of it could be observed in such practices where the son-in-law is obliged to visit his wife's hamlet and help his parents-in-law whenever they are in need. After marriage, the bride and the groom are often seen making frequent visits to the bride's parent's place and will assist them in their farm work. If they are from nearby hamlets, the son-in-law at times visits his wife's parents with one or two bundles of fire-wood or come and work in their fields whenever needed. Panli's son Murugan of Thaze-Abbannoor has married Vella's daughter from Thadikundu hamlet. After marriage, Murugan and his wife were seen often going to Thadikundu to help his parents-in-law and to assist them in their cultivation. They use to stay for weeks together at Thadikundu and come back when the work is over.

Though the traditional system of marital union through bride service is not observed among the Mudugas at present, it should be mentioned here that even now there are cases of marriage unions without formal ceremonies and rituals either. Thus there is a transitional stage in the process of change in Muduga marital union which lacks the old custom of bride service and at the same time devoid of formal ceremonies and rituals. After the negotiation between the respective families are been carried out, the boy and the

girl are free to start their marital life at anytime. Once the two kin groups arrive at a mutual agreement regarding the alliance, it marks the early phase of a marriage. If the bride and groom are from the same hamlet, it is often noted that a close interaction between the two households slowly starts. They begin to enter in the mutual exchange of labour and food. The bride often visits the groom's hut and assist her mother-in-law (*mami*) and sister-in-law (*attiai*) in household activities and other minor labours. She may eat from her in-law's hut and get *beethe* share of her family members. Nevertheless, during this stage, the girl tries to avoid the boy and will not sit with him or talk to him in the presence of others. Later, the girl begins residing in the groom's hut along with his parents. By now, both the bride and the groom start moving together and co-operate in agricultural activities. They together clear a separate field and start their independent cultivation. The next phase of the marriage is when the man erects a separate hut and starts their independent domestic unit. However, they maintain close interaction and exchange food and labour with his parent's household. As time passes, the marriage solidifies and after the birth of children, the community recognizes the relationship and accepts them. Years after during the occasion of their children's marriage or any other suitable time when a *panchayath (kalam)*¹⁰ is held, the husband and his agnates arrange the payment of the bride-price towards his wife's group. This socially marks the transfer of right over the children and the claim on his wife's bone after her death.

Case At Thazcabbannoor, Chathan's daughter Mathi was proposed for marriage with Neeli's son Raju a few years before. From then onwards the two families had very close interaction and frequent exchange of food. Mathi used to visit Neeli's hut very often and help Neeli and her daughter Pavashi in household activities or other farm work. However, she was reluctant in moving with her prospective husband and avoided talking to him or sitting with him in the presence of others. Both Raju and Mathi were getting a share of e\erung meal from each other's hut daily. Though Mathi spend most of the day time at Neeli's hut, helping her in household activities, both Raju and Mathi were not living together. At night Mathi slept to her own hut. But later in May 1996, when Raju was affected by heavy fever and was suffering from severe body pain, Mathi was asked to take care of him. Thus for the first time she spent the night along with Raju in a

separate hut preparing medicines and nursing him. From that day onwards they started living together which marked the beginning of their marital life.

This kind of marital union without formal ceremonies will also occur between members living in different hamlets. Once both the families express their willingness for the alliance, on any day according to their convenience, the boy or his parents bring the bride to their hamlet without any formal ceremony. Thus at Thaze-Abbannoor, Panali was very much interested in taking Vella's daughter from Thadikundu hamlet for his son Murugan. Since Panali had stayed with Yds family at Thadikunda for a longer period, they were having prior connections with that hamlet. Once the families have expressed their willingness for the marital union, Murugan's visit to Thadikundu became frequent and he used to stay for weeks at Thadikundu. During that time he stayed along with Vella's family, worked for them and at the same time developed intimacy with the girl. Later, when Murugan returned to Thaze-Abbannoor, he came along with his wife and stayed for few weeks with his parents. This marked the initial phase of their married life and there was no other formal ceremony or ritual for the mamage.

In olden times, there were also instances of marriage by elopement or by capture. The main reason for such type of mamage was due to the personal liking of the boy and girl to marry going against the wish of their parents and close relatives. Such a mamage also used to take place when forcible abduction of a girl occur without making due payment of bride-price. In this type of mamage, the girl used to elope with the boy or forcibly taken by him to a nearby forest or a distant relative's hamlet where they spend a few months of lonely and secret life. By that time, their parents come to know about the happening and having no other options, but to agree with the couples. However it is to be mentioned here that, this type of mamage is not socially sanctioned or permitted and is treated illegal by the society. Both the boy's and girl's family is obliged to pay an amount as fine towards the members of the panchayath. The attitude of the people towards mamage by elopement can be clearly revealed by a case from Thaze-Abbannoor.

At Thazeabbannoor, Kaden's son Ramaswami had eloped with Chathan's daughter Karim who had been divorced by Chellan of Mele-Abbannoor. After few months when the situation became calm, both of them returned to the hamlet and settled along with his kinsmen. Later, when Ramaswami expired and panchayath was held for

bride-price collector Kadu apologized before the *panchayath* for his son's mistake of eloping (*eduthodirathu*) with Karimi, and he himself kept Rs. 50 as fine towards the *panchayath*. But *moopan* and the elder members of the *panchayath* hesitate to receive the money as fine. However, Kadu explained that he is paying the money as a punishment for his son's mistake (*thappu*) so as to avoid this type of mistakes in future among the *oorukarar*.

When two families of the same hamlet arrive at an informal agreement to marry their children, it is usual among the *Mudugas* that the interaction between the two families become more close. The boy or his family starts offering gifts to the girl's family in the form of provisions like rice, oil, chilly, salt, etc., or to the proposed girl with items like soap, sweet, bangles, etc. This gift giving is not frequent and is made now and then until the marriage is held or the boy and girl start living together. However, it should not be concluded that these close interaction and gift giving will always lead to marital union. A case in support of this is of Nanjan's son Velli's marriage proposal.

Nanjan of Thaze-Abbannoor and his wife Beere had an idea of taking Chathan and Malli's daughter Mathi of the same hamlet as wife for their son Velli. Moreover, Velli also liked Malli very much. Nanjan and his relatives did not make any formal proposal to Mathi's family, but as a mark of their willingness for an alliance, his family started *beethe* relationship with Math's household. They accepted this and for few months they continued this *beethe* relation. When Mathi attained puberty, Nanjan's family gave a bag of provisions as gift to Malli's household. It was Velli himself who handed over the gift, which contained rice, dhal, chilly, salt, oil, soap, bangles, etc. However, Malli was not at all interested in giving her daughter to Nanjan's family and later when she realized that Nanjan's family is bent upon taking Mathi, she expressed her disinterest in this union saying that they have already decided to give Mathi in marriage to her brother's son Raju.

Thus the relationship between the two families got strained, and the *beethe* exchange was also stopped. However after one year, when Mathi's younger sister Nanju attained puberty, Malli approached Nanjan and his wife and agreed to give Nanju for Velli. Nanjan's family also accepted it since they wanted to renew their relationship with Malli's family. But Velli was not at all interested in this new proposal to marry Nanju.

and he was against his parent's decision in renewing the relationship with Malli's family. According to Velli, they did not give the girl whom he wished to marry, and now no other girl from their family could substitute that union.

Bride-price and its mode of transaction :

Among the Mudugas, bride-price is viewed as a transfer of money made between descent groups which symbolizes the alienation of various kinds of rights in a woman and the children to her husband and his kin. In the course of these transfer of bride-price and exchange of women, as Comaroff says, "these units create relationships of affinity and debt with each other, affirming their own internal solidarity and mutual interests in the process" (1980 : 15) Bride-price payment is an alternative form of bride-service. When the practice of bride-service is declining, it automatically reflects in an increase in the amount of bride-price. Thus during olden time when there was the practice of marriage by bride-service, the amount of bride-price paid was negligibly less, amounting to Rs 2¼, 5¼ or 7¼. Now-a-days, among the Mudugas, bride-service is very rarely practiced and there is seen an increase in bride-price to around Rs 251¼. But when considering the declining money value over the years, this can not be concluded as a drastic increase. However, the idea that the custom of bride-service has been declining among the Mudugas remains a fact.

It is noted that bride-service involves a transfer from one individual usually over a fairly long period of time, whereas bride-price payment typically involves mobilization of the entire members of the kin group to make an acceptable marriage payment. Among the Mudugas, often noted is the practice of a delayed bride-price payment which is delivered in a series of installments at different stages from the time of marriage. The dry-funeral ceremony, which is considered as the last stage for payment. Out of a survey of 75 marriages at Thaze-Abbannoor hamlet, it is found that bride-price payments were not yet made in about 37 marriages. In the remaining marriages where transaction is made, full payment is made only for 31 marriages and in 7 unions, bride-price is half paid. The survey also shows that formal marriages were held and bride-price payment were initially paid in only 5 cases.

There are different stages in the life of a man where he can make the bride-price payment of his wife. If the marital union is marked by a formal ceremony, the bride-price will be paid at the initial stage itself. Here, payment of bride-price will be a major event of the marriage ceremony. The *pariyam* (short form of *pariya-panam*, bride-price) is collected through a *panchayath* held by the council members and other elder members of the hamlet. The next stage of bride-price payment will be during the occasion of a marriage ceremony of any close relative of the husband or any other function during which a *panchayath (kalam)* is held for the collection of *pariya-panam*. Thus it is seen that during the bride-price payment of a younger brother, usually the elder brother's balance payment if any, will also be paid in that *panchayath* to their respective descent group members. In certain cases, a father's *pariyam* will also be paid along with the children's *pariyam* (see the case of Kakki's bride-price payment at Thaze-Abbannoor described above).

The last compensation payment a man usually makes during his life is when he 'buys the bone' of his wife. Such payments are not usually paid if bride-price is already paid. But however, if prior payment is not made, the payment made at the time of death signifies the bride-price payment, bone-price and the right over the children. Even if full bride-price payment was already made, a small payment called *bazhi-panam* has to be made at the time of death towards the wife's agnates as a token of assimilating the wife into her husband's clan.

Among the Mudugas, in most cases* the bride-price payment will be made at the time of the death of either of the spouses. During this time it is compulsory that the *pariyam* should be fully cleared, failing which the husband cannot claim right in the woman's body and bone and also right over the children. In certain cases, if the husband dies prior to the wife, then it is the obligation of his close kin to pay the *pariyam* to the wife's kin group, otherwise, they will object to carry out the burial. The wives group will argue out for the bride-price of their women. Equally, their women with a plaintain, they argue in the *panchayath* saying, "ennu bagu mundene kondu bannu ninnu marayathu nathine. Athuku naal't pah mulathithu E... And enu bagu marayam palium nanu eduthupome... The literal meaning of these words is that, ~ a plaintain has been taken from our basket

and was planted in your land, which later produced many seedlings. But till now you have not paid us anything. If you are not paying, we will take back our plantain and seedlings to our natal land".¹¹ However, in almost all cases, the agnates who have assembled in the hamlet for the funeral ceremony will contribute an amount to the *panchayat* and the collected money will be paid to the wife's kin as *pariya-panam*

(1) Marital union with formal ceremony

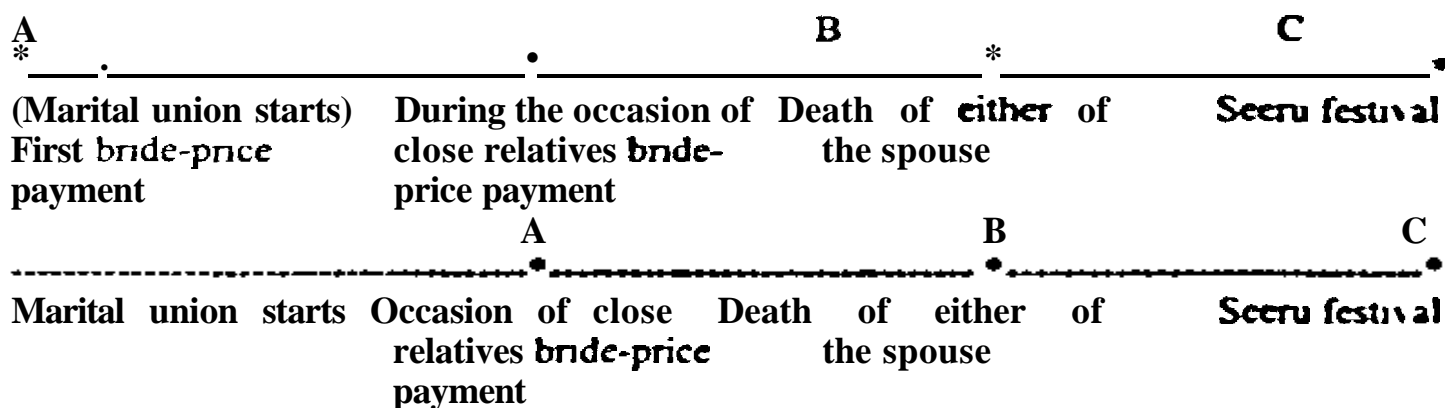

(2) Marital union without formal marriage ceremony

Fig 6 12 Stages of bride-price payment

Yet, in rare cases, *pariyam* will be made to pay during the dry-funeral ceremony which is called the *seeru* or *barasavu*. This is considered as the final stage (*kadesht kattan*) for the payment of the bride-price. Thus if the bride-price is not being full) paid at the funeral ceremony, then the bride's relatives would warn the husband's group saying, "*pariyamemma ellilu bankilamma*", which means that the bride-price will be taken from them during the *barasavu*(dry-funeral). Even if the bride-price is not being paid at this time, the woman's bone will not be allowed to keep in the sacred rock called *gobbe* for the second burial. However, there are no cases of people resisting to pay the balance bride-price during the dry-funeral.

It is the father who is having the sole responsibility to pay the bride-price for his son. But in the absence of the father, it is usually the elder brother who is obliged to make the bride-price payment for his younger brother. Similarly, a son is obliged to pay the bride-price of his father if any balance is remaining at the time of his father's death.

And, a younger brother will have to pay the bride-price for his elder brother if he has not paid it fully during his life time. In rare cases, a grand-son will also pay the bride-price for his father's father if it has not been paid-

in the same way, a father is having the right to claim the bride-price of his daughter. But in his absence, his son is having the right over the bride-price of his sister. In certain cases, if brother is also absent, it is the brother's son who is having the ultimate right to claim his father's sister's bride-price from his father's sister's husband's kin. In rare cases, a grand-son will be getting the right to claim the bride-price of his father's father's sister. Table 4.2 shows the number of cases where bride-price is given and received by the male members of Thaze-Abbannoor hamlet.

Table 6.2 Bride price paid and received by the male members of Thaze-Abbannoor

Bride price paid

FFF	FFyB	FF	F	FcB	F>B	FBS	cB	>B	MZS	S	wife
2	5	3	14	8	11	5	8	9	1	9	11

Bride price received

FFZ	FZ	cZ	yZ	D	FDD	BD	"SD"
1	16	13	24	9	13	9	1

Out of the total of 48 married males from whom data has been collected, it is found that in 37 cases the bride-price of a sister (including classificatory sister) has been received by brother's in 9 cases daughter's *parivam* is received by her father and in 16 cases a father's sister's *parivam* has been received by father's son. From the table it is evident that in 11 cases wife's bride-price has been paid by husband, and in 14 cases mother's by son. In 19 cases father's brother's wife's bride price paid by husband's brother's son, and son's bride price has been paid by father in 9 cases.

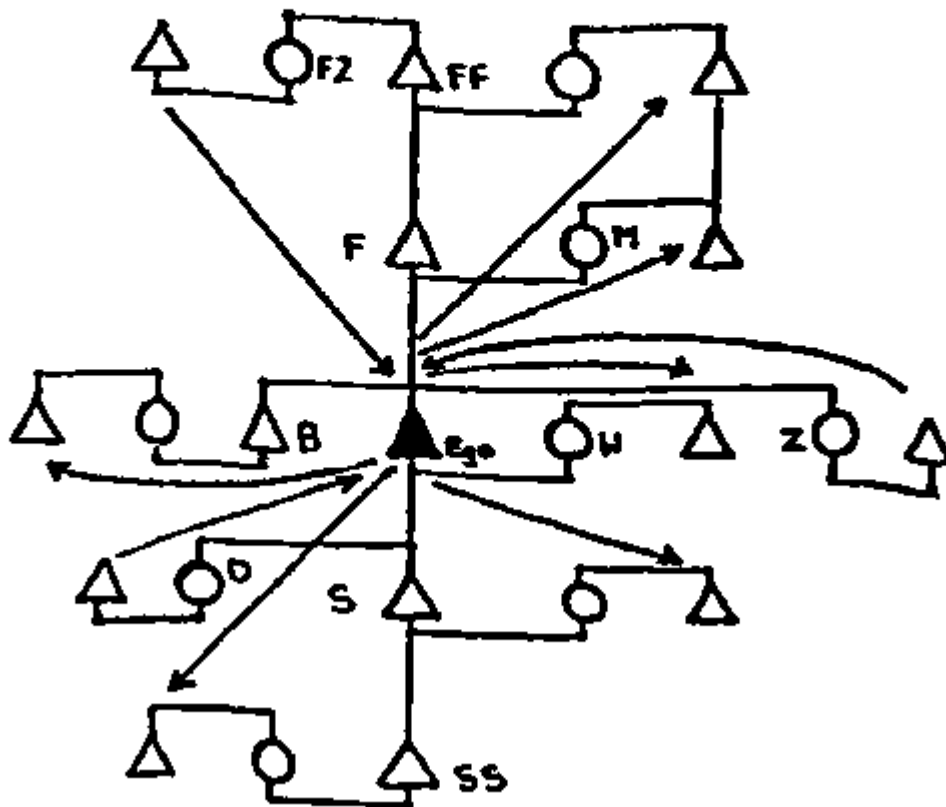

Fig 6.13 Paying and receiving of bride-price by a male ego

Thus from an analysis of the factor of bride-price payment, it is clearly evident that, among the Mudugas, a man in his life time is obliged to pay the bride-price of his father's mother, mother, FB' wife, brother's wife, son's wife and son's wife. At the same time he is having the right to claim the bride-price of his father's father's sister, father's sister, sisters, daughters and son's daughters. Here, the factor of bride-price makes for a clear distinction of relatives into two categories. One category consists of women who are agnates belonging to one's own descent group whose bride-price is received, and the other consist of women who are affines and are not members of one's own group for whom bride-price is paid. An important aspect to be noted here is that the FZ and M fall in opposing category, the former is grouped along with sisters and daughters who are

agnates and the later being grouped with brother's wife and son's wife who are affines. This distinction depicted through the aspect of 'giving and taking of bride-price' goes against Dumont's (1953, 1983) logic of Dravidian terminology which places 'mother' in the parallel category and 'father's sister*' in the cross category. ²

Separation and remarriage:

Among the Mudugas, when a man and a woman enter in marital union and start living together, there is no deal that both should live together and co-operate together until death. Moreover, there is no rule stating that one should have only one marital union in his life. Due to frequent quarrel and dissatisfaction in family life or in case of infertility, the husband and wife separates and thereby stop co-operating in domestic affairs and sharing of food and labour which informally marks the divorce. There are instances of divorce or separation between husband and wife due to the infertility of the spouse especially in the case of a woman ¹³ After separating from the husband, a woman may go back to live in her natal land along with her parents and brothers. Among the Mudugas, both men and women after separating from the first spouse are equally permitted for subsequent marital union. There is no difference in treatment between the first marriage and subsequent union. They never distinguish between first and second marriage on the basis of status as primary or main marriage, and secondary or subsidiary unions. All marriages are considered almost equivalent if it is taking place with the consent of their agnates and is also treated legal and socially sanctioned. The subsequent union will be given prestige and status if children are produced through the union and the bride price is paid.

No ceremony or ritual marks the start of a second marriage, and when a male and a female decide to live together and co-operate in domestic activities sharing labour and food, they have started their marital life. Cheludan's son Kail of Mele-Abbannoor had first married from Pothupadi hamlet. The marriage was formally held with ceremonies and rituals. But after one month, the girl separated from him and left to her native hamlet. After the 'divorce', Kail's parents were searching for a bride for him. Meanwhile, Kail fell in love with a girl at Karara hamlet. After few months, Kail came with this girl to Mele-Abbannoor and stayed in a relative's hut away from his

parent's hut. Kakki and the gni later met his mother and informed her that they are coming to their hut. After that, they both went to Kakki's hut. But the girl did not enter and was waiting a little away from the hut. Later, Kakki's younger brother, as informed by his mother, went and invited her to the hut. After entering the hut, she took the vessels and plates from the kitchen to the nearby stream, washed them, fetched water and came back to the hut. This informally marked the beginning of her life at Kakki's hut.

It has already been mentioned that, among the Mudugas, a man and a woman after separating from their spouses are permitted to enter in subsequent marital union. A man is allowed to take a second wife if his first wife dies or is unable to bear him children. One can enter in as many union as he can, but the Mudugas never maintain more than one marital union at the same time. Thus polygamy is not practiced among the Mudugas. Out of a total of 107 married members belonging to the 40 households at Thaze-Abbannoor, it is found that 3 of them had married thrice and 20 had married twice in their life time. This practice of entering in many subsequent union may be illustrated with the help of few cases.

Case 1 Nanjan of Kallamala hamlet after his father's death was staying with his mother at Anavai, his mother's natal land. From Anavai, Nanjan went to stay along with one of his sisters married to Thundoor hamlet. Later Nanjan shifted to Kinnakara where he had another sister residing there. While he was at Kinnakara, his sister's husband proposed his mother's sister's daughter for Nanjan. Though Nanjan did not agree to it in the beginning, later started living with her. But there occurred frequent quarrels between the husband and wife. According to Nanjan, his wife showed little concern towards him and was not capable of managing the household affairs. Later, Nanjan got separated from her and went back to Anavai hamlet. From Anavai he came to Thaze-Abbannoor where his elder sister Chathi was staying. While he was at Thaze-Abbannoor his sister Chathi and her husband Chonke started searching a girl for Nanjan. Later, Mele-Abbannoor Kullan's sister Maruthi from Mele-Abbannoor was proposed, and after getting the consent from her family, Nanjan started living with her. He erected a new hut near his wife's parents and also cultivated the fields nearby his parents-in-law. Nanjan then shifted his stay to Anavai. However, Nanjan's life with his second wife was also not different from that of the first. According to him, frequent quarrels do occur between them because of

her disobedience. From Anavai they shifted to Karara hamlet. While at Karara, marital discord and mal-adjustments occurred between them, and Nanjan had to separate from her. Later he came back to Thaze-Abbannoor and was staying along with his sister Chathi and brother-in-law Chonke. At this time Nanjan became close to Chathi's first husband's brother's daughter Vellachi, who has been divorced by Bokken of Thaze-Abbannoor. They both agreed to live together and Nanjan started his marital life with Vellachi. This marital life lasted only for just two weeks. Vellachi's FyB Neelan advised Nanjan to avoid living with Vellachi since she is in the category of daughter-in-law for him. Thus Nanjan got separated from Vellachi. After this Nanjan went back to Karara hamlet and is staying along with his sister who has shifted from Thundoor hamlet to Karara.

Case 2: At Thaze-Abbannoor, Kaden's marriage was held when he was eighteen years old. He married his classificatory father's sister's daughter Mallika from Boodar hamlet when she was very young. She stayed along with Kaden in his parent's hut. Later, she gave birth to two children. After this, Kaden always used to complain about Mallika's lack of concern and care for the children, and she became the target for blames. She rarely stayed at Thaze-Abbannoor, but was moving around visiting relatives in other hamlets. Because of her misbehavior and inability to manage the household affairs, frequent quarrel occurred between them which finally led to divorce. After one year, Kaden left Thaze-Abbannoor and went to Kattakkad hamlet and stayed along with Kuppen who is a distant 'maman' (mother's brother) for him. After about three years, Kaden became very close to the *oorutarar* and they all wanted Kaden to marry from that hamlet. At that time, Kaden was interested in Kalki's daughter and he conveyed the matter to Kuppen and his wife. Kuppen informed it to Kalki, and later the girl and her parents agreed for the proposal. Later, Kaden presented a bag of provision as gift to the proposed girl's parents and thereafter started living with her which marked the beginning of their marital life.

Kaden then went back with his wife to Thaze-Abbannoor and stayed along with his kinsmen. But after one year, his second wife died. Then again after one year, Kaden married Ramu's daughter Poliche from Anakkal hamlet. Poliche gave birth to four children. At present Kaden is living along with his third wife at Thaze-Abbannoor.

Case 3 : At Thaze-Abbannoor, *mannukaran* Kakki first married Neelan's daughter Vellachi from karuvara hamlet who was also his mother's sister-in-law's daughter. This was a marriage by sister exchange since Kakki's sister was in turn married to Vellachi's brother Chellan. In this union Kakki had two children. After the death of Vellachi, Kakki married his father's classificatory brother-in-law's daughter Chathi from Mele-Abbannoor. He had three children in that union. Later, due to Chathi's ill-health, Kakki separated from her and married his MBD Neeli from Veetiyoor. He is having three children in this union, and Neeli is now living along with Kakki at Thaze-Abbannoor.

No ritual or religious ceremony is associated with the separation of husband and wife due to divorce. Among the Mudugas, the word divorce is referred by the term "*bantham bidrathu*", literally meaning, "to give up relationship". Jural divorce is impossible and not practiced, but conjugal separation followed by a subsequent union is a viable alternative among them. Because of the importance placed on mutual services-domestic and sexual, as the major aspect of marital life, there is no surprise that conjugal separation practiced by the Mudugas makes little distinction from formal divorce. For when a couple ceases to live together, services inevitably lapse. Once a man and a woman separates, there will be no more relationship between them and their interaction comes to an end. This is clearly conveyed in one of their proverbs saying, "*satha uravu irikkum.. vitta uravu theerum*", which means that relationship and interaction may be retained even with the dead, but not with one who has divorced. In certain cases, if divorce happens immediately after the marriage before begetting children, then the bride-price, if paid, will be returned by the wife's family to the husband's family such that the husband will not retain any right in her.

Though a man and a woman are free to separate from their marital life, it is to be mentioned here that, other relatives especially parents of the spouse have no right to force them for divorce. This act of forcing or leading a couple to separate from their marital life is seriously objected by the people. At Thaze-Abbannoor Beere's daughter Cheen has been married to Nanjan's son Rangan of the same hamlet. Rangan and Cheen were staying along with Rangan's parent's family. Though Rangan was very loyal and full concern towards Cheen, her *manam*. Nanjan's behaviour was very harsh and always found fault with her. One while scolding Cheen, Nanjan crossed his hands and beat his

daughter-in-law. Cheeri complained this to her parents. That day at Thaze-Abbannoor, a *panchayath* meeting was going on for the bride-price payment of Chellan's son Murugan. Beere approached the *panchayath* and after keeping Rs.10 as *dakshina*, put forward her case. She complained the *panchayath* that her daughter has been suffering this torture from her father-in-law since her marriage and requested the *panchayath* to separate the union. Then Nanjan was called to the *panchayath* and formal enquiry was made, and finding him guilty was asked to keep Rs.20 as fine towards the *panchayath*. However, Beere was not satisfied with this and she argued for the divorce. Both the husband and wife-Rangan and cheeri, were called to the *panchayath* and when asked about their opinion regarding divorce, Cheeri replied that she had no problem with her husband and was not willing for a divorce. Then the *bandari*, who was heading the *panchayath* explained to Beere that the present *panchayath* is not to break a union which was united in some other *panchayath* but will only try to solve the issue. Since Beere was arguing for the separation without the consent of the couple and thereby trying to break a family life, the *panchayath* found her guilty and was asked to keep Rs.51 as fine.

Among the Mudugas, there are certain rituals associated with funeral ceremony which formally marks the widowhood of a person. A woman who has become a widow is called *mundassiar*. The moment a woman becomes a widow, her bangles will be removed and it is put in the hands of the dead body of her husband. A little hair from the right side of her head and the black beaded necklace (*keeramula*) will be removed and is tied to the big toe of the right leg of the corpse. Before the corpse is taken for burial there is another important ceremony called *kodi idrathu* where the brother of the woman puts a cloth over her head which formally marks her widowhood. Once the ceremony of *kodi idrathu* is performed, then she should abstain from remarriage and should remain as a widow throughout her life. Usually this ceremony is not performed if the woman is very young. For a man, *kodi idrathu* ceremony is done by his sister.

If a woman dies in the early phase of her marriage without begetting children, she still belongs to her husband's group and the *pur* or *param* has to be paid to her kin group as compensation towards her body and bone. However, women will be assimilated into their husband's descent group only after their death. If the husband dies very soon after

marriage without any heir, then usually **bride-price** need **not** be paid and **the wife will** return to her natal land and go for another **union**. In certain **cases**, she remains in **her** husband's hamlet and will get married to her **husband's** real or **classificatory** brother. If she is married to her husband's brother, an additional **bride-price** need not be paid. But how ever if she begets children for husband's brother, an amount as **compensation for the** right over children is paid at the time of his her **death**.

If a woman after **separating from** her first husband **gets married** with a man from another kin group and begets **children**, the right of **that** children belongs to the second husband and his descent group on **payment** of compensation. Thus at the **time** of her death, both the husband's kin group will be paying **bride-price** to **the** woman's group. However, the husband who has become the **genitor** of the first child borne by her is having the ultimate right on the **woman's** body and bone. The second or subsequent husband's payment is considered as a compensation for the right over the **children** born to them.

Even if a woman has separated from her first husband and remarried another man and living with him, she must and it is her obligation to attend the funeral ceremony of her first husband through whom she has begotten first. She should also **observe** certain rites connected with the **funeral**. That **is**, although the second husband **is** having right in her labour power and right of sexual access **in** her, these cannot be taken as full right on her body and hence her **bone**.

If a **woman** has married more than once and has borne children in each marriage, where husbands are unrelated, then a dispersed groups of maternal half-siblings are possible. In certain **cases**, young sons may accompany the mother **when** she remarries, and remain there under the control of the **step-father**. He may **even work in** the farm for **his step-father**.

In a cultural system where **shifting of land is widely practiced**, people rarely hold a land permanently. This nature could also be seen **in** relation to their marriage system. Even though monogamy **is** the **rule**, among the **Mudugas**, a person **is** not restricted to only one spouse in his life time and the remarriage of a person after the **death of his** her spouse is not at **all uncommon**. A person is having right not **only to** a particular field but have the **right** to shift from one to **another when necessary**. However the **genitor**

substance of the plant depends on the **genetic** substance of the respective seeds **sown**. Thus women who is equated with **land** is not restricted to a single **person**, but *others* can have subsequent access to her on the death of her first **husband**. Similarly, every subsequent cultivators have the right in the crops produced by **them**. But the **ultimate** right of the land rest with the one who has cleared **it**, sown seeds **and** harvested the yield first.

Another analogy used by the people to explain the right on a **woman** and the children born to her is that of 'hunting'. People say **that**, while in the case of **hunting**, the right of the animal goes to the one who had first shot the animal. Analogous to **marriage**, this means that normally the man who had first **married** a woman is having the right over her. However, they added to it saying **that**, it is not only the question of shooting the animal first which matters, but should be capable enough for making wound on **its** body and the blood should ooze out as a clear mark of evidence. This analogy shows that, even if a man has married a woman, he will not be having strong **claim** in her unless he has produced children who are the real proof and evidence of **marriage**. But again for them, if a man had shot the animal and have produced deep **wound**, and if goes **without** taking the game, he cannot normally claim the right. The next man **who** had caught the animal will have a right on it. This clearly points **out** the **fact** that just begetting children is not the only criteria for the right in the **wife** and **children**, but can have a strong claim only if they are taken care **well**.

This analogy clearly explains that the actual right **over** a woman rests with the husband through whom **she** had given birth first. But in case if he separates from her and had not taken care of **them**, then he can **claim** the **right** only after **paying** an amount as *fine-sakkukooli*, towards the woman's kin group.

The rules regarding rights in **wife** and children and its actual practice can more clearly be understood by looking **into** specific cases of **bride-price** payment as the time of funeral ceremony. Thus the case of **bride-price** payment during **Lacchi's** funeral shows how it is really working out. **Lacchi** of *VeccUyoor* hamlet first married **Kakki's** daughter **Neeli** from the same **hamlet**. They are having two **children** in that union. Later **Lacchi** and **Neeli** separated, and **Neeli** got married to **Kakki** of *Thaze-Abbannoor*. After that,

Lacchi married a widow (Malli) from Kallamala hamlet who had a son in her first union. Lacchi is having no children in this second union.

When Lacchi died, issue regarding the right over his first wife Neeli became a matter of serious debate among the people. The situation became complicated when Neeli herself was not willing to accept the bride-price and to give the right of her 'body and bone' to Lacchi's group mainly because of the rift she had with Lacchi. However, Lacchi's close agnates did not want to give up and were bent upon getting the right in her bone and the children. Neeli's brothers also agreed in favour of Neeli, saying, "When our girl got separated from her husband and was alone with her children, your people were not to be seen and never came for her help, and now in the final moment you are coming for the right"

When the issue remained unresolved, Lacchi's kingroup decided not to proceed with the bride-price payment towards Neeli's kin group for the time, but to settle the bride-price of Lacchi's present wife Malli from Kallamala. Meanwhile, Gandu of Anava hamlet who is Neeli's son's father-in-law (thus classificatory brother for Neeli), entered and he tried to pursue the matter. After a lengthy talk, he convinced Neeli and made her agree for the transfer of right on her 'body and bone' to Lacchi's group. Gandu took the role of the groom's jathi and the panchayath was joined for the collection of bride-price. Rs 201 % was earmarked as *pariyam* towards Neeli. Gandu gave the money to the bride's jathi and he gave it to Neeli, who handed over the money to her father's brother Iyyas.

After receiving the money, Iyyas took the bands of Lacchi's children and gave to Lacchi's brother Man. This symbolized the transfer of the children, and the right in Neeli's body and bone to Lacchi's group. Man, then gave Rs.25 % to the children and asked them to place before their mother's brother as *thaimamanpanam* (MB's money).

After this, the issue regarding the bride-price of Kallamala wife was taken up and the panchayath decided to pay Rs. 101 % as *pariyam* towards Kallamala group. Lacchi's Kallamala wife's brother was called and asked about the amount he is demanding. He replied that he came to Veetuyoor to attend the funeral of his *machan* and not for collecting the *pariyam*, and have no demand but will receive whatever they give. Then Gandu, who is the groom's jathi said, "Your sister came and toed here the *carud* our man...., she fetched water for him . made *raiputu* and served him. hence it is our

obligation to pay the price towards this. When the *pariyam* was handed over to Lacchi's wife. Gande said to her, "ithu ninnu panam (this is your price). *nec eeku banthu bele seethathukku* (since you came here and worked for our man) *tthu banku, ninna nattanekku kodu* (take this and give it to your brother)".

Later, Lacchi's both sons and his present wife Malli, and her son were called to the *panchayath*. Gande then advised Lacchi's sons, "this is your *sinnamma* (mother's sister), and your brother. Here after you have to take care of them. You should consider her son as your own brother. In future your wives should not ill-treat her"

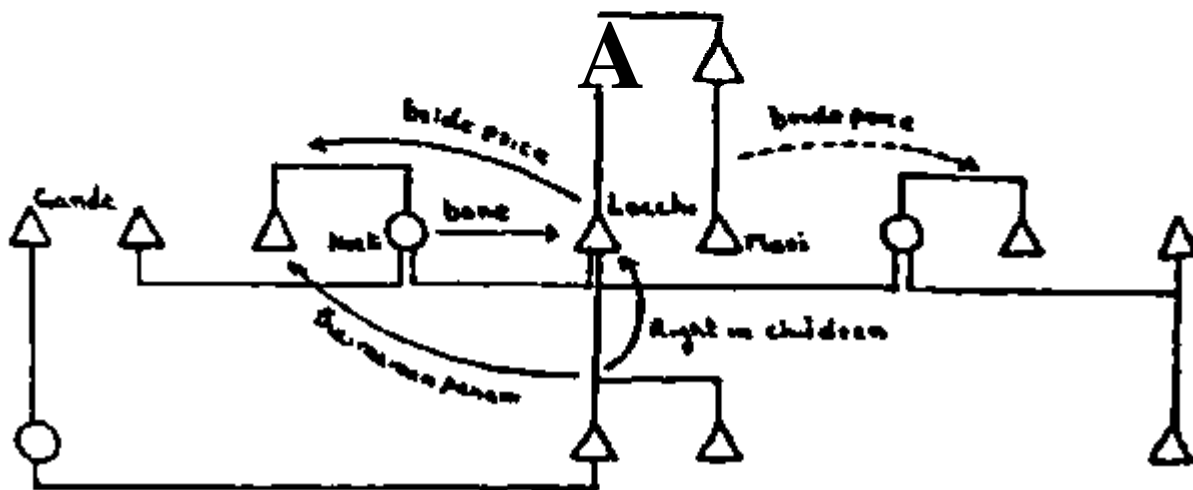

Fig 6 14 Bride-price payment during Lacchi's funeral

It should be noted that the right over the present wife's bone and her son was not claimed by Lacchi's kin group since this right goes to her first husband's kin group and in future when they approach claiming the right, they have to be given back.

Though Lacchi separated from Neeli, his kin group had the ultimate right in her bone. By making the bride-price payment, the right in her bone and the right in the children has been retained by his group. Thus it is to be mentioned that divorce means the disruption of the personal relationship between a man and his wife but does not deprive the husband's kin of residual rights in a wife and her children.

Determinants of bilateral **cross-cousin marriage**

According to Homans and Schneider (1955), the major determinant of unilateral cross-cousin marriage is the locus of jural authority. But revising Homans and Schneider's theory of extension and the assumption of differential affect towards FZ and MB, Allan D. Coult (1962) put forward his explanation that the determinant of unilateral as well as bilateral cross-cousin marriage is the jural authority to dispose of a woman in marriage. His hypothesis to account for bilateral cross-cousin marriage holds that it will occur in societies in which jural authority over a female is either vested in the woman herself or is split between her **matriline** and **patriline** (bilateral authority). On the basis of the above hypothesis, Coult (ibid) asserts that bilateral cross-cousin marriage should be associated with bilateral societies, since it is in these societies that the greatest occurrence of bilateral jural authority would be expected. But he adds that if bilateral cross-cousin marriage occurs in unilineal society, jural authority will be bilateral or woman will have right of self disposal in marriage.

The occurrence of bilateral cross-cousin marriage among the patrilineal Mudugas can be closely associated with the right and authority or obligations attached to certain category of kin. Among the Mudugas, the initiative in marriage is taken by the father of the boy, without whose consent the boy's maternal kin or the boy himself cannot do anything. However, it is to be mentioned here that the authority is not fully vested with the father, but the mother will also share the right and authority and have a major role in the decision making of her son's marriage. On the other hand, either the father or the mother of a girl will under no circumstances demean themselves in tending proposal for the marriage of their daughter. Rather, they wait for proposals to come from their kin circle for their daughters.

There exist strong sibling solidarity among the Mudugas and since a father is having intimacy and close link with FZ, he prefers to propose his TO for his son. Similarly, a mother takes initiative in making proposal for her son with her brother's daughter. This type of situation regarding the locus of authority and initiative in marriage can be attributed to a tendency towards bilaterality exhibited by the Muduga society. However, Mudugas cannot be labeled as a bilateral society though it shows tendencies of bilaterality like strong alignment between MB and ZS with reciprocal exchange relation.

with maternal kin and affines, and women retaining relation with their natal group even after marriage. Since it is not a bilateral society, there cannot be expected a bilateral jural authority. but only tendencies of bilateral jural authority which is depicted by the sharing of locus of initiative by the father and mother. However, this right and authority in marriage enjoyed by the mother in no case is extended to the MB as in the case of bilateral society. Rather, the authority is restricted to members within the nuclear family.

However, according to Coult, it is not the jural authority over a male seeking a wife but over the female being sought as wife which is the immediate determinant. Thus it is significant to mention here that even though neither the F nor the M form the locus of initiative in marriage of their daughter among the Mudugas, the authority and right over a daughter lies with both the father and mother. Hence, the veto power or the final decision whether to accept a proposal or not with regard to the marriage of a daughter is shared by both the father and mother. Without the consent and decision of the girl's parents, the maternal kin (MB) or paternal kin (FZ) of the girl cannot do anything.

Thus Coult's thesis associating bilateral cross-cousin marriages with societies having bilateral authorities cannot be fully rejected. Taking lead from his theory, the tendency towards bilateral authority depicted by the patrilineal Muduga society could answer the occurrence of the bilateral cross-cousin marriage.

The Mudugas-Kurumba intermarriage :

The Mudugas of Attappady do not constitute an endogamous group in the ideal sense but intermarry with their neighboring group, the Kurumbas, with whom they have frequent interactions. There exist no status difference between the two groups and they have a mutual 'give and take' relationship. The Mudugas consider the neighbouring Kurumbas as their allies and equivalent to them and are included in their endogamous circle with regard to marital exchange.

Table 6.3 shows the details of marital exchanges in 9 Muduga and 2 Kurumba hamlets which have taken place with the other hamlets of Attappady including the Kurumbas. Data shows that out of a total of 472 marriages recorded from the 9 Muduga hamlets, 121 (25.63%) were with the neighbouring 5 group Kurumbas. From the table, it is understood that marital exchanges take place more frequently between hamlets that are

situated nearby. Similarly, it is noted that the percentage of marital exchange with Kurumbas are more when the hamlets are in close proximity. Thus Mele-Abbannoor, which is the closest Muduga hamlet to the kurumba area is having the maximum percentage (36.58%) of marital exchanges with the kurumbas. Thaze-Abbannoor which is also located near to Male-Abbannoor is having 3333% marital exchange with the Kunimbas. Similarly, the table shows that Anakkal hamlet is having 3333% marriages with the kurumbas, Veetiyoor 20%, Pottikal 19.48%, Mele-Kakkupadi 13.79%, Thaze-Kakkupadi -17.64%, Cholakkadu 18.75 V and Ommala 21.73% marriage relation with the Kunimbas.

The details of marital relations from the two Kurumba hamlets where survey has been conducted shows that, Thadikundu which is closest to the Muduga area is having 39.47% marriage exchange with the Mudugas and Thaze-Thodukki which is comparatively far away is having 27.90% of marriage with the Mudugas.

The notion of descent aspects in contracting marriage relationship* and the concern to maintain strict endogamy among themselves is to an extent very weak among the Mudugas. The Muduga-Kurumba alliance relationship cannot be explained based on a single and particular reasoning, but there are various other factors also which have their role in permitting this marital exchange between the two groups.

The Mudugas and Kunimbas inhabit in almost the same geographical and ecological setting of the Attappady valley. The Kurumbas are seen towards the uplands and hill slopes comprising the Pudur panchayat while the Mudugas are restricted to the South Western foot hills and the plains of the Attappady range comprising mainly the Pudur and Agali panchayats. Thus certain hamlets of the Mudugas in Pudur panchayat and the border areas are in close proximity with the Kurumbas which malts them to maintain frequent social interaction with their adjacent group. But at the same time it is noted that the Muduga hamlets in Sholayur panchayat situated far away from the kurumba area have less interaction with the Kurumbas.

Table 63 on marriage geography of the Mudugas shows that the percentage of Muduga - Kurumba marital exchange is maximum between feamkis when they are in close proximity and is minimum between hamlets situated far apart especially in the case of Muthikulam hamlet in Sholayur panchayat which « having no marital relationship

with the Kurumbas. Thus it is strongly assumed that this geographical nearness and their inhabitation in similar ecological setting makes for a strong and frequent social interaction between the two groups which in turn must have led to the intermarriage.

Apart from the Mudugas and Kurumbas, the third tribal group inhabiting the Attappady valley of Palaghat district are the Irulas. Among these three tribal groups, Irulas numbering more than 19,000 is numerically dominant and the Mudugas around 2,755 and Kurumbas around 1,280 are numerically very less which when put together is just 1/5 of the entire Irula community.¹⁴ Moreover, the Irulas believed to have migrated from the border areas of Tamil Nadu and settled in Attappady are strictly endogamous and maintain very less interaction with the Mudugas and Kurumbas and there exist a high degree of taboo between the Irulas and these two groups in marital and dietary habits.

This demographic aspect together with the strong similarities in customs and practices, and their frequent social interaction are some other factors creating a favorable situation which makes the Mudugas and Kurumbas enter in alliance relationship with each other

Myths and stories prevalent among the Mudugas show evidence that the ancestors of both Mudugas and Kurumbas were related as brothers. The Mudugas and Kurumbas are different tribal groups and have variations. But they are both of a similar kind at the structural level existing in close proximity, and maintain close interaction. There are ample historical evidences through many of their myths and stories depicting the Muduga - Kurumba interaction and their marital relationship which had prevailed from the very olden period itself. Among these, one of the Myths clearly says about the alliance relationship which had taken place between Mele-Abbannoor hamlet and Anavat Kurumba hamlet.

In the very olden time there lived a Panan and Patu (great grand parent*) at Mele-Abbannoor hamlet and another Patan and Patu at Kadukummannu which is a Kurumba hamlet. The Kadukummannu Patan and Patu used to visit Mannarkad market once in a month to trade forest products and to buy household provisions, and they always went via Mele-Abbannoor. During that time, the Patan of Mele-Abbannoor was in heavy dispute and rivalry with another Patan of a nearby hamlet. One day he attacked Mele-Abbannoor and killed both the Patan and Patu and ran away leaving their small child

That day the Pattan and Parti of Kadukumannu while passing Mele-Abbannoor on their way to Mannarkad, heard the crying of the child and were shocked to see the old parents lying dead. They felt pity for the small child and tied a cradle on the branch of a nearby tree and kept the child in it and went to Mannarkad. While coming back from the market, they saw the small child sitting very happy after eating the food which they had kept near him. The old parents liked the child very much and took him to their hamlet, cared him and brought up along with their daughter.

When both the boy and the girl reached maturity, the Kadukumannu pattan decided to get his daughter married to the Mele-Abbannoor Pattan's son. But when the boy came to know about this, objected it saying that since he had grown up along with the girl from childhood in the same hut, she is like a sister for him and cannot even think of marrying her. But the Kadukumannu Pattan wanted the boy to marry only his daughter and forced him for the marriage. Afraid of this, the boy had no other option, only to run away from the hamlet. Seeing this, the Kadukumannu Pattan chased him, and when the boy was nearing Anavai hamlet, the Pattan cried aloud to Anavai Pattan to catch hold of the boy who is running away. That time Anavai Pattan along with his seven daughters were engaged in their farm work. Hearing the words of Kadukumannu Pattan, Anavai Pattan asked his daughters to catch the boy. Thus the seven daughters chased the boy and caught him by the shoulders of his dress from either side. He then removed his clothes and tried to run away from them. Seeing his struggle to escape, all the girls started laughing and they felt pity for him and tried to save him from the Kadukumannu Pattan. Later the boy fell in love with the girls. Knowing this, Anavai Pattan expressed his willingness to give his daughters to the boy and gave shelter from Kadukumannu Pattan allowing him to stay with him for few days. After that he married the seven daughters and came back to Mele-Abbannoor his natal land.

The above myth shows that alliance relationship between the Mutugas and Kurumbas is not a practice which is of recent origin, and it is evident that a similar sort of relationship existed between Mele-Abbannoor and Anavai Kurumba fcalet. Even now Mele-Abbannoor people consider Anavai people as their affines and Kadukumannu people are treated as *anna-thampi*.

Another important factor making for the alliance relationship between the Mudugas and the Kurumbas and its continuous occurrence is the very nature of their kinship terminological system. The Muduga terminology divides the entire relatives into two categories — marriageable and unmarriageable. The terminological distinction into categories and the cross-cousin marriage rule embedded in it exist in order to regulate raamage. Among the Mudugas, marriage exchange operates very rarely giving prior importance and consideration to the notion of descent group exogamy. That is, they give preference to category rather than group. If a union occurs between a patrilineal segment of the Mudugas with that of the Kurumbas, the nature of the kinship terminology assimilate the new members into the kinship universe systematically categorising and defining the affinal relation. An important aspect of the categories is that, they are a permanent and ordered constellation, and once a marriage union is established, this alliance relationship forms an enduring system with the structure remaining unaltered. There is always a functional correlation between the terminological categories and exogamy. These terminologies systematically categorise and define marriageable partners in the entire kinship universe of any person. This nature of their alliance operation based on the rule of categories giving less importance to descent criteria permits to contract further marital exchanges with the Kurumbas with distinct descent groups, without causing any structural alteration.

It is very apparent that both the Mudugas and Kurumbas represent a homogenous social system and they are two of a kind at the structural level. Both have a patrilineal descent organisation with a positive marriage rule permitting bilateral cross-cousin marriage and there exist no status difference between the two. The most important thing to be mentioned here is that in both the system, the ratio of corporate kinship (descent) to alliance is the same⁵: that is, in both system, there is a strong emphasis on corporate kinship but an equally strong emphasis on alliance. There are also other structural similarities in both the system i.e., the brother-sister tie or the sibling solidarity is strong and significant among both the Mudugas and Kurumbas, at the same time the marital tie is relatively weak. It is also noted that, irrespective of their descent nature, there is a strong complementary filiation among the Mudugas and Kurumbas. The Mudugas and Kurumbas represent two separate systems each consisting of various interrelated parts

functioning together. However, it is observed that parts of both systems show certain similarities in structure as well as functioning which facilitates the smooth interaction between these two systems without creating structural disturbances or disintegration. This structural similarities has its definite role and functions as a major factor for the existing Muduga - Kurumba marital alliances. This particular nature of the two systems and their similar functioning could very well answer the widely prevalent Muduga-Kurumba intermarriages.

NOTES :-

1. There is no terminological distinction which differentiates between **elder** and **younger** cross-cousins. This shows that the relative age of spouses is not an important criterion in the selection of a bride or groom, and the **potential** mates of an individual are usually the **cross-relatives** of his own **generation**.
2. Though the dimension of generation is central to **Dravidian kinship system**, it is not uncommon to find cases of generational equivalence or the merging of **kin** types between generations at least with regard to behaviour (see **Trautmann.1981**). Nevertheless, **Yalman (1962; 1967)** strongly argues for the importance of generational distinction when he says that the rule **restricting** an individual to **marry** a person from his own generation is as important as that of prohibiting parallel cousins from sexual intercourse.
3. Among the **Mudugas**, **Sunday** is considered as the most auspicious day to start with the marriage procedure and moreover if so the **bride** could enter the groom's hut on the next day, i.e., **Monday** which is also considered as an auspicious day.
4. **Aan-jathi** is an affine to the groom's family who act as the mediator or 'third man' for the groom's side and **pennu -jathi** will be an affine to the bride's family who perform the role of the 'third man' for the bride's group during the **panchavath** meeting.
5. **Pakkala-panam** is also known as **muthalpanam** which is the initial amount placed before the **panchavath** by the groom's father or his immediate agnates towards the payment of **bride-price**.
6. **Mudugas** also equate the groom with cattle herder (**mattar**) and the bride will be equated with female **cattle (madu)**. In some cases, a woman will also be equated with a plantain and the children with the **seedlings**.
7. In few cases of marriage ceremonies (especially during the marriage of **Kaden's son Kali of Mele-Abbannoor**), after the **bride-price** payment is over, there is a short ritual which symbolizes the union between the groom and the bride. For this, a betel leaf is taken and after applying lime, it is torn into two halves and each half will be taken by the groom and the bride and they exchange it. Following this, a glass of water is

be given to the groom and after drinking half of it, he gives it to the bride and she completes it. After this, the bride's *jath* will take the hands of both bride and groom clasped together and give it to the groom's *jath* who then pass it over to the groom's father.

9. *Mappilakalare* affines especially 'son-in-laws' of a descent group or *kootam* who are in charge of cooking and serving of food which is considered as their obligation on ceremonial occasions of the particular descent group

9 The "compensation interpretation" views bride-service as a transaction where the goal of young men is to obtain and control rights in women, and that of fathers is to obtain adequate compensation before giving up their daughters. Since women are considered valuable as producers and reproducers, their kin groups are reluctant to part with them unless they are compensated for the cost of raising them, and for the future return that could be expected from their labour (see Bossen 1988)

10 Since the Mudugas hold the *panchayath* meeting in the front-yard of huts or the open space in the centre of the hamlet *katam*. the *panchayathis* also referred at a *katam*

11 This equation of women with a plantain and the children with the seedlings clearly depicts the aspect of complementary filiation inherent in the Muduga kinship

12 Inconsistency in Dumont's scheme of cross/parallel distinction has been noticed by many anthropologists (Gough 1959, 1966. Tambiah 1958, Allen 1975, Good 1980 Reddy 1984) asserting that Dumont's logic of placing mother* in the parallel category and * father's sister* in the cross category is misleading, and argued for a terminological analysis which corresponds to the actual kinship configuration in a society

13 Any marital union unable to beget children will never be recognised and given due prestige and status by the society. At Thaze-Abbannoor, \ *ellinkun* and *Kade* were not having any children even after few years since their marriage. This created suspicion among the family members especially her parents-in-law and she was sent back to her hamlet doubting that she is a sterile woman (*burath*) who can never give birth to children. However, one year later \ *ellinkun* himself went and fetched her back to his hamlet and through a medicine-man (*gumular*) could be able to find out

that she was affected by some evil spirits. Counter treatments were done through magic after which she became pregnant.

14. According to the Attappadi Tribal Development project survey, 1991.
15. Leach notes (1961:26) that "in any given social system, we shall always find some kind of notion of corporate kinship which stands supposed to some kind of notion of alliance as p is to q, but what we can usefully compare as between different societies are not those particular p's and q's (regarded as separate institutions), but the ratio of p to q considered as mathematical function".

rites of passage and prestations

The Muduga social organization is viewed as a complex net work of exchange and transactions of gifts and assistance between agnates and affines particularly at the tone of ceremonies and rituals. Life-crisis rituals provide the most conspicuous context for public and formalized gift exchanges and various responsibilities and obligations.

Life-crisis rites occur at points in an individual's life when some significant change is thought to be taking place in his social position. The events have an economic aspect and exchange, and interaction between affines forms a major part. These are ceremonial occasions performed in a broader social context and viewed as special circumstances in the sense that rituals come to be the occasions of gift exchanges and the discharging of obligations. The affinal obligations and mutual exchange of gifts and prestations operate at the primary core within a limited circle formed ideally by two affinally connected households/families, and through the rule of extension establish laterally to a wider circle. Following is the description of exchange of gifts and obligations between the two categories that take place on various life crisis rituals.

Child birth .

The social organization of the life crisis which the birth of a new member constitutes include a series of accepted behaviors both for the mother and her kin and affines. Delivery and child birth is one such crisis situation calling for the observance of ceremonies for the good of the mother and the child. Some of these observances are ritual in nature, others are designed to protect the fecalfeh of the mother and baby and some may combine these functions.

When a woman becomes pregnant for the first time, in the fifth or seventh month, her parents invite both the husband and wife for a ceremony called 'kodi beru sori' (first-pregnancy feast). During this ceremony rice is specially prepared and along with curry made of chicken is served for the fecobaad and wife in plantation leaf. This

ceremony is attended **only** by closely **related** kin. After finishing the **food**, the **woman** keeps **Rs.5 ¼** under the **leaf** in which she **ate**. This amount **will go** for **her attai** (usually her brother's **w**ife) **who** serves food and takes the **leaf**.

Among the **Mudugas**, **birth** should take **place** in the **husband's** hut attended by her husband's kin usually husband's mother, **husband's** sister or even husband's mother's mother. At the out set of child **birth**, the woman is placed in a state of isolation and is considered impure and she is treated as if she **were** ill. After the **birth**, the **umbilical cord** is cut and the **placenta** is **buried**. After **delivery**, the mother » put **into** certain restrictions and thus separation procedures include **seclusion**, sexual and dietary prohibition and cessation of household **activities**. The mother and **the** child are secluded in a **corner** in the **dheetti** (varandha) of the hut. Sometimes a compartment is **made** in the corner **where** the mother and the child remain **secluded**. The seclusion **normally** lasts for about one month. But **now-a-days** it is **observed** for 7-10 days after **which** she resumes her normal routine.

A temporary screen **will** be made in the back **side** attached to the **main** hut for the mother to take bath and to bathe the child. This is made of **cycas** leaves (**eenihupatta**) by the husband himself. Mother and the child takes bath in hot **water** duly. The mother's **attai** prepares hot **water**, and assist the mother in bathing the child. She is not **allowed** to take bath in the stream or pond **where** the other members of the hamlet bathe and fetch **water**. The mother is restricted to a **diet** of **rut puttu** (food made of ragi Hour) and curry made of **tamarind** known as **pulirasan** for so **en** days. During these seven days she is **not** allowed to take **rice** and other food items. She **will** be given separate mat to steep and plates for food and nobody touches it. Her husband's sister (**attai**) takes care in preparing and **sen** ing food for her. Sometimes food is prepared and **giv** en to the mother **from** close relatives or **beethakarar**.

When a **woman** is under birth pollution, her **husband** should not hunt game and should **avoid** eating meat. Since **delivery** brings pollution to the **hut**, it **return** affects the husband and to a certain **extent** the **god** of hunt **arivu**, which is installed in the **hut**. If a man goes out into the forest for **game** when his wife is under pollution, it **will** bring wrath of the **arivu** and will not be **getting** any **hunt**.

A woman takes the cessation of her menstrual period to be the first indication of pregnancy and looks for other symptoms. They have little interest in calculating the expected date of the birth, but if asked, they may estimate that it is due in particular season of the year, generally seven or eight 'crescent moons' (*lombu*) after the first sign of pregnancy appears. A woman's everyday activities change little when she is pregnant. A pregnant woman makes no elaborate preparation for the delivery of her child. She carries on her usual work in the hut and field until the first sign of impending labour, and then she moves into a corner of the *dheetti* of her hut. After around one week since delivery, even before pollution is over, she may go out to the near by forest for collecting fire-woods and also attend minor agricultural works in the field. However, she restricts herself from cooking and entering the kitchen. Thus as Van Gennep says, "the physiological return from child-birth is not the primary consideration, but that instead there is a social return from child birth" (1909 46)

After the pollution is over, the mother and the child takes bath in hot water applying turmeric. On that day, special food is prepared with rice or *same* and given to the mother along with chicken curry. After this the mother resumes her daily routine. The floor of the hut especially *dheetti*, where she was secluded, will be plastered with cow-dung. Even after the pollution is over, the mother continues to take bath in hot water for about two months.

Among the *Mudugas*, there is no practice or custom of keeping the child in cradle (*thotta*) but is always found along with the mother in her lap close to her body covered by her upper garment. They believe that if a child is put alone in a cradle to sleep, it will be affected by evil spirits known as *pichashu*. After the birth of a new baby the recently-weaned child slowly separates from the mother and will be seen most of the time with his/her father. They rarely demand for milk and silently watches the mother suckle the baby.

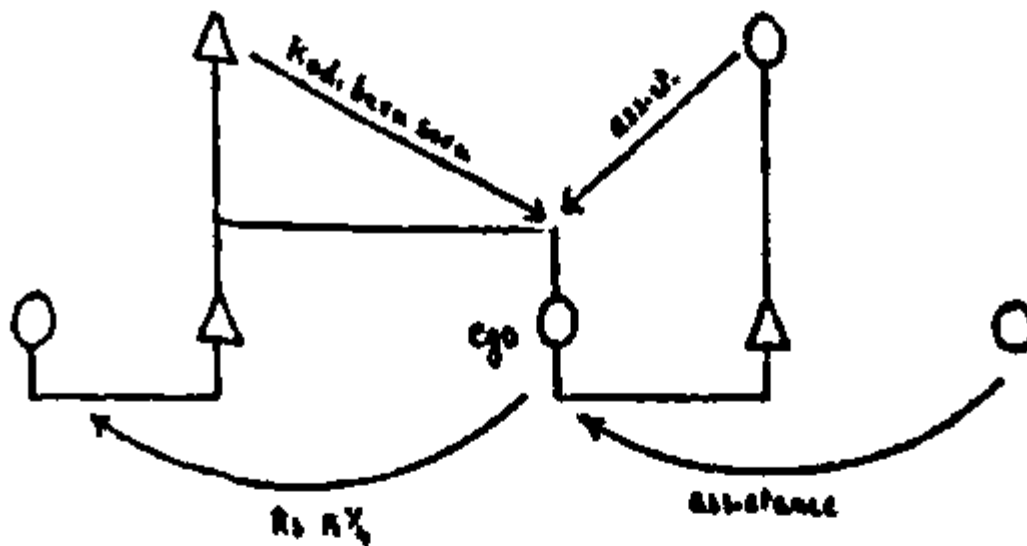

Fig 7.1 Exchange associated with child-birth

Naming : The naming of a child is usually done during the third or fourth week after birth. The name giving will be performed by immediate agnates like FF, FeB, FyB or even father. A child should be named after a patrilineal ancestor of the appropriate sex. So that, a boy should be called after his close agnates like FF, FeB, FyB, etc. and a girl after her paternal ancestors like FM, FBW, etc. Van* gi ing is not a major ceremony and is confined to the immediate kin circle. During the name-giving ceremony when the child cries, few names of the ancestors are tried and the name at the mention of which the child stops crying is regarded as the apt one. This way of naming a child practiced by the Mudugas is known as *agarishu peru patishraita*.

Mudugas believe that if ancestor's **name** are not given to the **child**, it would be an offence against their ancestors and bring **wrath** of their **ancestors** resulting in **the death** of the child. If **repeated** death occurs in a particular family, it will create **doubt** in the family members and through a shaman (**pattukaran**) will find out the **cause**, and as a remedial measure will agree to keep the particular ancestors name for **the next child**. **Naming** ceremony is considered as a rite of **incorporation** which introduces the child **into** the society. It anchors the child to the descent group establishing **its patrilineal** kinship to other members by identifying him with one of **his ancestors**. **Although** names are also chosen in other **ways** than the ideal **one**, it is still from a limited set belonging to a wider patrilineal group, which shows **that** both personal identity and social continuity **is** maintained.

Tonsure Ceremon> : When the child reaches the age of 2-3 **years**, the first **hair-cutting** ceremony is performed. The '**hair-cutting**' ceremony is performed by the mother's brother, and usually the mother's eldest brother has the **right** to do **this ritual**. The mother's brother keeps the child on **his** Up and **ritually** cut a **small tuft** of **hair**. After the ceremony, the child and the **mother's** brother **are given** food together. The **mother's** brother is presented with a **veru** (white cloth) and **tenpanam** (i.e. **Rs.2.50**) is given (**now-a-days** it is about **Rs. 5 ¼**) The amount is given by the **child** to the **mother's** brother which is kept under the plantain leaf in which he took food. Only close relatives participate in this ceremony and it is **never** an occasion for elaborate **celebration**.

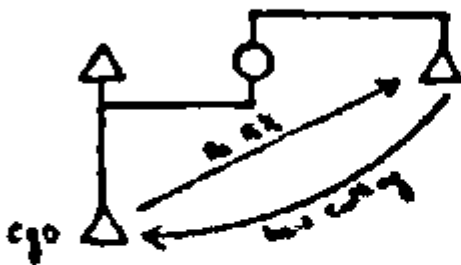

Fig. 7.2 Exchange associated with tonsure ceremony

Ear boring ceremony : This ceremony is observed when the child reaches an age of 3-5 years. The child often has its ears pierced by the mother's brother. *Kara mulla* (thorn of a wild plant) is used to bore the ear and after boring the ear, a small thorn is kept. Later this thorn will shed automatically when the ear-hole enlarges and an ornament called *kadukkan* is put in the ear of the boy, and *kammal* in the case of a girl. Ear-boring is not considered as a major ceremony and no formal feasting is held.

Puberty Ceremony ; Puberty mark the physical and social transition from childhood to adolescence. This is a period marked by seclusion and considered polluted and amounts to certain restrictions. There is a separation from ordinary life and social relations, entering a phase of liminality and subsequently reincorporating into society in their new status. Among the Mudugas, a girl is permitted for marriage only after attaining puberty and most often marriage takes place one or two years after puberty

At the onset of a girl's first menstruation, she is secluded to a screened-off portion in a corner of the *dheetti* (*varandha*) The screen is made of cypress leaves. Sometimes a small temporary hut (*sethe*) is made adjacent to the main hut and this will be built by a male cross-cousin (*machan*) of the girl. She is led into the hut by her female cross-cousin (*attai*) who will be assisting her most of the time and serving food for her until the pollution is over. She observes seclusion from other members and will be given separate mat to sleep and plate for food. Milk, butter, milk, curd, ghee etc. are prohibited during these days

Among the Mudugas, the attainment of puberty is known as *mutuli polraika* (to overflow) or *bavasikka banthathu* (coming of age), and the girl is considered impure and polluted during this period. However, it is the occasion of celebration and formal feasting for the Mudugas. This mixed attitude towards attaining of puberty is noted by Dumont when he says, "the ceremonies are linked to the celebration of the event on one hand and to the impurity associated with menstruation on the other" (1986:269). Thus the three states which one passes through in a puberty ceremony are impurity and pollution associated with it, isolation or separation from the rest of the society and the final phase of purification.

The girl leads a secluded life inside the *scath* for about seven days. On the seventh day she takes a ritual bath in a near by stream accompanied by her *attiai*. Turmeric water will be sprinkled on her body and the old clothes which she was wearing will be put to fire. After the bath when they come back to the hamlet, in front of the girl's hut, a wooden mortar (*urai*) and pestel (*ulakka*) will be kept. Holding the pestel, they together ritually pound a little *same* grains three times. Then both enters the *dheem* of the hut. At this time, the *attiai* (either MBD or FZD) will present the girl a plate of auspicious items which include *adukku* flowers, tender flower cosmos sulphureus, of jack tree (*salle-peeli*), comb (*korika*), mirror, needle and thread, oil, etc., which according to the Mudugas are symbols of fertility (*pillaphalam*).

After this, the girl and her *attiai* (also referred as *thunakkan* meaning companion) together sit for food served in the same plate. The girl takes a handful of rice and when she is about to eat, the *thunakkan* will tap on her hand making the rice fall in the plate. This will be repeated three times. Then the *thunakkari* takes a handful of rice and when she is about to eat, the girl beats on her hand making the rice fall. This will also be repeated three times. After this, both the girls will eat from the same plate. Another plate of rice will be given to the *thunakkan* which she takes to her hut. The beating of each others hand is a major event of the ceremony and is called *kaithatrashu*. This ritual act shows the closeness and the mutual right and obligation between MOD and FZD (*attiai*). This is followed by a formal feasting, and rice is cooked and is distributed to the entire hamlet. This rice prepared on the occasion of puberty ceremony is called *niruntha Laya*. During this occasion the mother's brother will make gifts like clothes, oil, sweets, bangles, etc., to the girl. This ceremonial occasion on the seventh day of puberty is called *elidathinaneram* (the day of bringing out).

With this, her pollution and secluded life will not end completely. She again has to lead a semi-secluded and restricted life (a seclusion which will be repeated more briefly during later menstrual period) for seven days. But the place of seclusion changes and now she sits in a corner of the *dheem*. Thus the period of seclusion lasts for a total of fourteen days after which she takes bath and enters the hut. This ceremony of entering the hut is known as *kooraputhinaneram* (day of entering the hut).

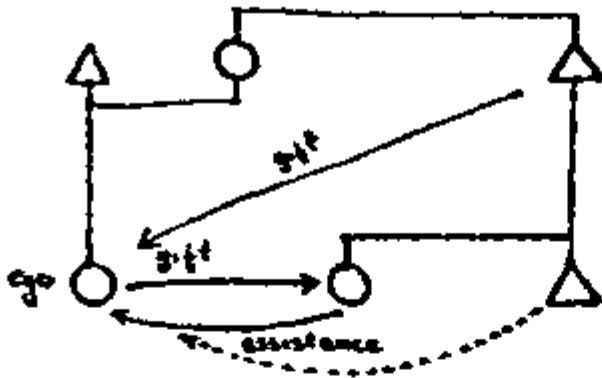

Fig. 7.3 Exchange associated with puberty ceremony

Marriage Marriage among the Mudugas brings together not only the two families but the entire descent group in an alliance relationship. The chain of gifts of presentations exchanged between the affinally related families symbolize the alliance tie and constitute the most important features of marriage relationship. Marriage is generally considered as a contract between two groups which is more an economic contract and less religious. Schematization takes place. It brings in a transfer of women from one family to another and from one group to another. Through this transfer there is always a loss for one side which is an economic loss and is compensated through bride-service and bride-price.

The major transaction associated with marriage is the *paripujawan* amounting to Rs 251⁴, which is paid during the marriage ceremony or in a later stage. For meeting this amount, a formal collection takes place among all the agnates *ama-thampi* who have gathered there, which may be called as a sort of "internal presentation".

1983:81;1986:256). The amount received as **bride-price** for their daughter will be distributed among the close **agnates of the bride's** femTK. An amount of Rs. 10' is paid as **thaimaman-panam** (mother's brother's money) to the maternal **uncle** of both the bride and the groom as a compensation for the right he was having in his sister's children as spouses for his own children.

The bride's father who receives the **pariyapanam** is supposed to make a counter presentation consisting of a cattle and other household **utensils**. (For detail description of marriage procedures, see Chapter 6).

After the marriage there follows the exchange of gifts between the groom's and the bride's house which consist of household provisions like rice, oil, chully, salt, dal, sweets, etc. These gifts are earned from one house to the other in baskets when the married couple gives formal visits called **manavachi**, first from the groom's hut to the bride's and then from bride's hut to the groom's.

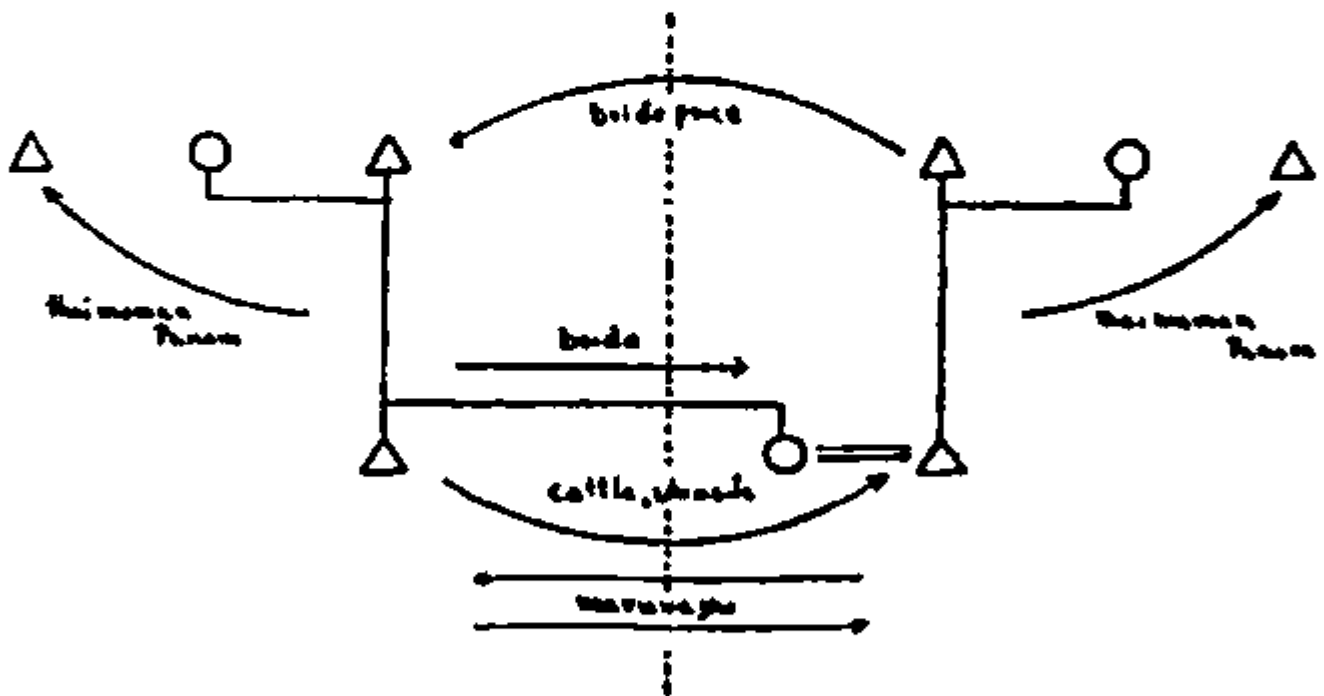

Fig. 7-4 Exchange associated with marriage

Death and funeral ceremony : Like birth and other life-crises, the people passes an organization of the experience of death which is met by the mortuary rites and practices associated with it. The dimension of the social and cultural organization of death can be understood through an analysis of beliefs and conceptual schemata about death and also through the manner in which the crises of death is managed within the group. Like other rites of passages, death also represents a transition from one status to another, and as Van Gennep (1909) says it follows three distinct stages, 'that of separation, that of transition and that of incorporation*.

Among the Mudugas, the ritual and ceremonies associated with death are interconnected to the total social system not only in the symbolic significance within the conceptual frame but also in the kinship and other social identities of the main ritual participants. Thus there is seen a formalized pattern of interaction and prestations which involve not merely material gifts, but exchanges of rights, duties and obligations of all kinds between the two categories, agnates and affines. Certain roles may be performed by the agnates of the departed, whereas others are the duty and obligation of his affines.

Among the Mudugas, immediately after death, the corpse is covered in white cloth (*mundu*) put by his close agnate especially son or brother or even father in the case of a young man, and the women gather round the body to weep. Message (*saru sari*) is sent to all kin and affines in other hamlets and usually kinsmen residing in the same hamlet will go as messengers. If anyone is overlooked, he or she will be extremely angry at affront and keeps away from attending the funeral. On the other hand non-participation in the funeral, even after receiving the message and if this act is considered a serious breach of the social relationship.

Later, the body is displayed in front of the hut by creating a small rectangular structure called *goodagara* covered on all four sides top with sarees or long clothes. Fresh plantain stems along with leaves are used as pillars at four corners. The cutting of plantain symbolically represents the separation of a person from his group like the plantain which is separated from its group. The corpse is placed on a ladder like bamboo bier called *kani* or *kana*. The bark of *Kawitree (Helecterispora)* is used as string to tie the bamboo sticks in making the bier. The preparation of *kani* is a rite of affines.

During the funeral of Kalamoopan of *anakkal* hamlet, *kattil* was prepared by *fañs* three son-in-laws and his 'sister's children.

Close relatives (agnates and affines) from other hamlets come in small groups. Each arrival is marked by a renewed outbreak of crying. The women come and sit round the corpse under the *goodagara* and keep wailing. Men will stand near the head part of the corpse for a few seconds and then as a mark of respect touch the head of the corpse and then touch their forehead.

Among the Mudugas, wailing is a major event of the funeral and this is done by almost all the women close and distant who have assembled for the funeral giving it a sort of ceremonial status.⁴ While wailing, the women will be uttering the past events and happenings in the life of their departed relative with a rhythm of its own. This weeping at the funeral is called *paleme solliagarurathu*. Ceremonial wailing is a symbol not only of sorrow but of social ties, the function of wailing is based on the assumption that all participants will come to feel positive sentiments of social bonding by joining in the prescribed behavior. Those who feel no direct sorrow themselves will nonetheless weep which provides a source for the sentiment that is transformed in ritual.

The Mudugas believe that these wailing or lamenting function as invisible tentacles which hold back the soul of the departed relative from leaving that place immediately. The more time they spend in weeping or wailing the more time the soul is held up and the more honor they give to the deceased. Soon after death, burned charcoal will be kept under the corpse to avoid evil spirits from 'attacking and taking away' the corpse.

Among the Mudugas, it is considered as an important obligation for one to attend the funeral of one's relative and to wail for the departed. Non-participation to attend the funeral is treated seriously and it remains a life long debt for them. Thus later they have to visit that hamlet and should express their grief and sorrow by wailing in the deceased relative's hut till the sorrow subsides. This custom of wailing as a later stage is called *saavuku elavu veedurathu* (paying the taeral debt). In a case at Thaze-Abbannoor, when Mathan's children died, Mathan's elder brother's daughter-in-law who was married to Chittoor hamlet could not attend the funeral. But five months later when she visited Thaze-Abbannoor she straight away went to Mathan's old hut, where the

children last stayed, and kept wailing expressing her grief and sorrow, thereby fulfilling her obligation which remained as a debt.

An important event of the funeral ceremony is the offering of white clothes (*sarwa seela idurathu*) where close relatives including both agnates as well as affines keep a white cloth near the corpse as mortuary gifts. This circle of near relatives usually include father, siblings, children, cross-cousins, brother-in-laws, son-in-laws, etc. At Thaze-Abbannoor, during the funeral of Ramaswami, *sarwa seela* was put by his close relatives which includes his father Kaden, father's two younger brothers, father's father's ekier brother's son, father's father's younger brother's son, Mother's brother, sister's husband, wife's father's younger brothers, wife's classificatory elder brother, wife's mother and her two sisters

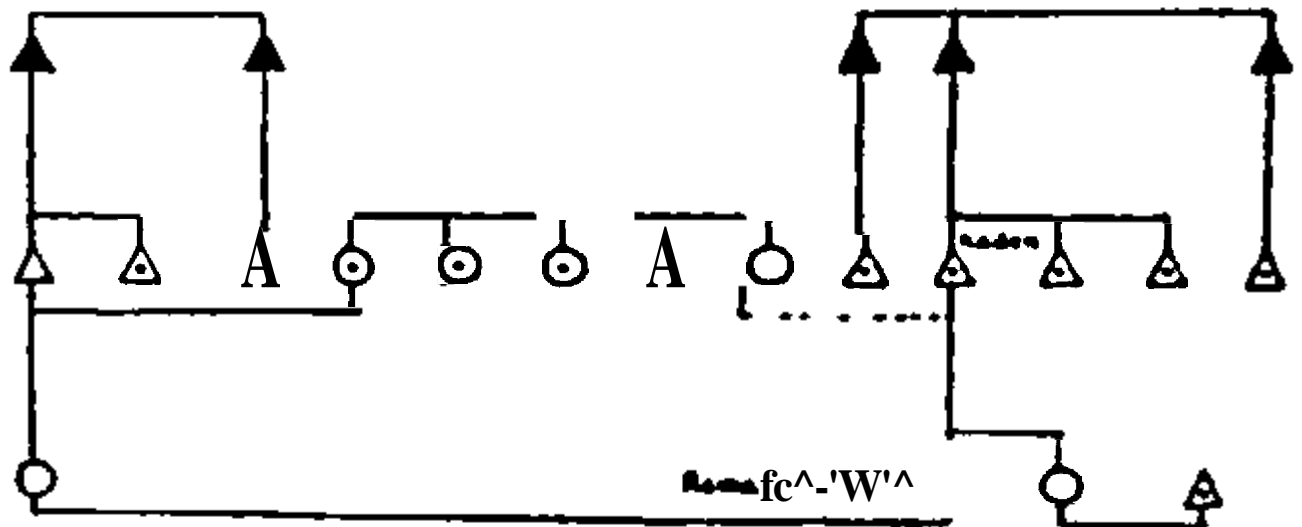

Fig. 7.5 Relatives who offered *sarwa seela* during Ramaswami's death

Usually in a hamlet where a death has occurred men are seen sitting in small groups here and there in the corners of the hamlet or in the *dheeri* (*varandha*) of their relatives hut gossiping and talking about their departed one. At the same time in another corner of the hamlet, preparation will be taking place for drumming and dancing which is the major event of the Muduga funeral. *Para* (drum made of earthen pot with leather on one side), *davil* (cylindrical wooden drum with leather on both sides) and *lavai* (flute) are the major musical instruments for the funeral. They warm the leather of the instruments by keeping near fire so as to make it firm and tight to get better sound. Now slowly young men and girls gather round the 'musicians' and will be eagerly waiting and making themselves ready for the event.

Then the drumming starts, accompanied by the music of flute and it alone continues for about an hour. Then at last, the drums and the flute begin in earnest and the young men and girls start to dance. The number of dancers slowly increases as does the crowd of onlookers. The noise and excitement grows and there are little sign of grief. Gradually the focus of activity shifts from the women to the men, from the decreasing wailing to the increasing dancing.

Women and girls dance in a close circle round the *godagara*. The elder boys and men join together so that there are often two or three concentric circles one enclosing the other. The dancers in the inner circles move very slowly with rhythmic foot work forward and backward clapping their hands together in an anti-clockwise direction. Men who are in the outer circle will be little fast in their foot work stamping hard on the ground. The movements and style of the dance varies according to the songs and the music played. Each singing and dancing last for about half an hour which (abrupt!) ends in an outburst of shouting and whistling, and the dancers retreat. This event of dancing, singing and drumming during funeral ceremony has its own meaning and function for the total system.

Men of important social status like *maemularan* (priest *moopun* (headman) elderly persons are buried with elaborate rites such that the funeral is a feast usually attended by large number of *fcimnvti* honouring the deceased by drumming, singing and dancing day and night for two to three days. They believe that the more days they walk and dance, the more they are honouring the deceased. This is clearly evident when the

people often say, "*aattum pattum bettu ellam nalamakki bidadam*", meaning flat 'through elaborate dancing and music should make the funeral better and send the dead one happily and in proper manner to the other world' Thus as Huntington and Metcalf says, "it is a vehicle for the expression of a considerable range of emotions, grief and exasperation fade into an act of honouring...the dead man" (1979: 38).

The dancing and singing accompanied by music will continue all through the night till dawn except for small intervals after every round. Rice or other food grains will be distributed to every family in the hamlet depending on the number of relatives from other hamlets staying with them. This share of rice called *veerupadi* is cooked in each hut and is served to their relatives assembled there from other hamlets. Black tea will be prepared and is served frequently. The entire expenditure towards this will be met by the immediate agnates of the deceased. Once the corpse is displayed outside, it marks the event of drumming and dancing held for one or two days and the immediate agnates have to bear the entire expenditure. The display of corpse in the front yard of the hut under the *goodagara* is called *saw kalakku bakruthu*. In very rare cases like the death of young members or when a family is running short of money to bear the heavy expenditure, the body will not be placed in the front-yard for tinging and dancing in an elaborate manner.

In the morning, people disperse for their primary needs and assemble again after a gap of one or two hours. Elder members then gather together in a corner and start discussing about the bride-price and other issues related to it. If the bride-price is not yet paid or any balance remains, a *punchavath* consisting of the council members of the hamlet and other elder members from both party adjourns to settle the issue and collect money towards the bride-price (for detail see Chapter 6)*

When all the expected relatives are present, the corpse is taken to the backyard in front of the hut for washing. Both the agnates and affines gather for this bathing of corpse. CXI is applied on the head and the body is washed with turmeric paste. Silver coins are stuck on the forehead using the latex of jack tree. A four anna coin is kept in the mouth and then milk is poured. This is also done immediately after the death. If the deceased is a married man, then the wife's bangles will be removed and put on the hands of the corpse and a hole in the hair from the right side of her head is removed and tied to the big toe of the right foot of the corpse. For washing the corpse "pouring of water" over the head

(*thanniatturathu*) is done by affine of opposite-sex, and thus for a male, this will be done usually by his brother's younger wife. She takes a pot full of water and raise it up and down three times and then pour the entire water over the corpse's head. She also apply oil (*enna atturathu*) on the head and turmeric paste on the face and chest of the corpse.

Now another ceremony called *urumai atturathu* follows, which is also performed by the affine of opposite-sex. Thus for a male, this is done by his female cross-cousin (*attai*) or any other who falls in this category. For this she takes a little oil in her right hand and after folding touches the outside of the palm to the chest of the corpse and keeps the inner side towards her own chest. This is done three times and then she keeps a silver coin on his forehead and takes back another. Those who are doing the *urumai atturathu* will be given Rs. 10⁰⁰ as *urumaiattapanam* by the agnates of the deceased. With this amount, they usually buy a small chicken and will keep in the name of the dead person. This chicken is called *urumai atta kochi*.

The word *urumai*⁷ carries the meaning, "right" or "claim". This term is used to describe the right and obligation of a male cross-cousin over his female cross-cousin. Since it is the real cross-cousin who is the rightful and apt spouse, when in actual practice marriages take place with others who are not real cross-cousins, this ceremonial or ritual act of *urumai atturathu* symbolically represents the non-negotiable right and obligation of a person over his / her real cross-cousin. Moreover, this ritual act clearly depicts and is the expression of the notion that the alliance relation is inherited through generations. Even if a man has married his MBD, his FZO will have the right to perform the *urumai atturathu*.

During Kalamoopan's funeral ceremony at *anakkal feamkt*, *thanni atturathu* was done by his younger brother Rangan * wife and *urumai atturathu* was performed by Kalamoopan's MBD Maruthu.

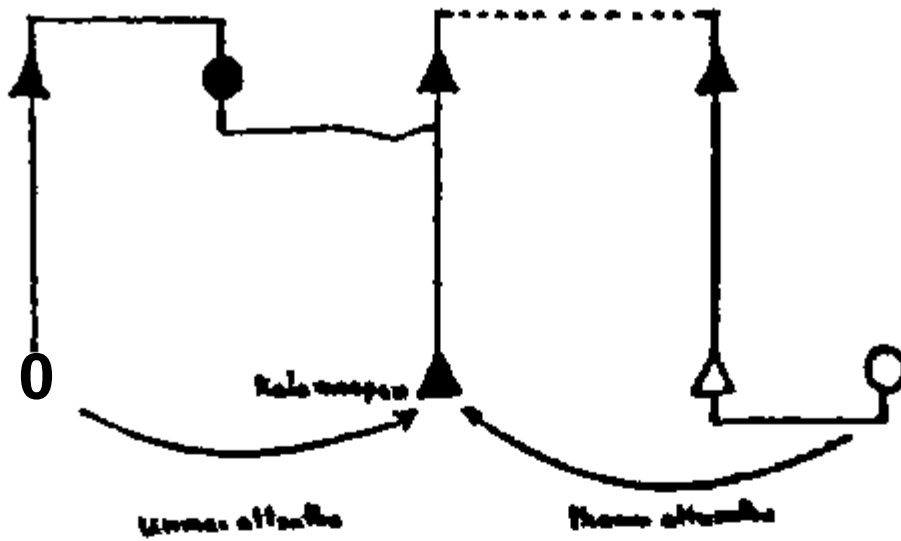

Fig 7 6 *Urumai atturathu* and *thanni atturathu* during Kalamoopen's funeral

At Thaze-Abbannoor, during Ramaswami's death, *thanni atturathu* and applying of oil was done by his classificatory elder brother's wife who is in the category *attai* and *urumai fl/wro/Ai#* was performed by his classificatory sister's daughter who is also his wife's younger sister (*attai*)

aloud. This ceremony marks her widowhood. If the deceased is a woman, then her husband's sister will perform the *kodi idurathu* for the widow.

At the same time, a little amount of *rai* flour is made into paste and with that along with a particular variety of grass known as *Karalappilla* and a little hair from the right side of their head, the agnates (*anna-thampu*) rotate the corpse in an anti-clockwise direction and keep the *rai* flour and grass along with the hair on the right side of the corpse. The affines (*macha-maman*) rotate in clockwise direction and keep the *rai* flour and grass along with the hair taken from left side of their head on the left side of the corpse.

Now it is the time for the final round of dancing and singing when more than a hundred of them including men and women, young and old gather round the *goodagaru* in circles dancing fast stamping their foot hard, clapping their hands and singing loudly. This creates an atmosphere of extreme noise with loud wailing, singing, drumming and shouting. As a mark of their last honour and homage to their departed, men and women dance vigorously and sing aloud.

Oru mara sole
minnal mara poove
minnal mara poo parikkan
poku modajathikale
la-le la-le la te

(One-tree forest
lighting-tree flowers
to pluck those lighting tree flowers
when you come again my affi
la-le la-le la-le)

When the singing and dancing is about to end, the *goodagaru* will be dismantled and the agnates will hold the four corners of the bamboo bier (*kurai*) on which the corpse is placed so as to proceed to the graveyard. At this time, the ceremony of *Kamath-pudikrathu* takes place when the dead man's sister's son ritually obstructs the procession by sitting on the corner of the bamboo bier and *toli* back. He will recede only if

some metal objects like steel pot or knife is given on assurance that a cattle will be gifted to him later by the deceased's agnates. In the case of a woman, her brother's son will perform the *kattakal-pidikrathu*.

At Anakkal, during Kalamoopan's death, his younger sister Malli was seen weeping aloud all through the day with unbearable grief and sorrow. When the final round of drumming and dancing was about to over, she burst into loud cry hitting herself and rolling on the ground. However, when the *goodagara* was being dismantled, she was seen searching in the crowd for her son Mallan. And later when the corpse was about to be lifted, she compelled him to obstruct the procession by holding back the leg of the bamboo bier. Mallan came forward and then sitting on the edge of the *kattilon* which his mother's brother's corpse was laid, held it back not allowing them to proceed. Immediately, as advised by an elder agnate of Kalamoopan, his son Murugan handed over a small steel pot to Mallan assuring that a cattle will be given in future and to be satisfied with it at present. Receiving the pot, Millan wept aloud and both cried holding each other's shoulder. With the small pot in his hand and weeping aloud, Mallan was seen walking away from the crowd.

When the procession reach a few yards outside the hamlet, they stop to perform yet another ceremony called *semia-cheyrathu*. Here, the dead man's wife takes three circles round the corpse with an earthen pot of water on her head. While doing this, her brother follow* her with a small tickle with which he lap* the pot making a small fock through fehich the water oozes out. After the thud round, on reaching the foot part of the corpse, she drops the pot towards the back side breaking it to pieces.

After this the funeral procession proceed* towards the graveyard which will be situated a little away from the hamlet in the forest. Women are usually fe*t*-M« fr enicnng the burial ground and they return to the hamlet, or weeping aloud they watch the procession till it fede out from their sight. The corpse placed the bamboo bier is earned by affines holding on four corner* with the leg towards the An eibtagane of the deceased leads the procession screwing the gramof ruual some all the way up to the grave yard. The parts of the dismantled *goodagara* will be carried along with the procession and is thrown reaching a particular place called feAi^Jt*.

After entering the grave-yard (*chudala*) they identify the place to dig the grave near to where their agnates have been buried. Before digging the grave, an elder agnate of the deceased with a *kauri* flick ^{holding upside down ritually} digs three tones* on the ground. Then few others especially the affines start digging the pit which will be about 4 feet length 3 feet width and 4 feet depth. After the grave is ready, three small strips of white clothes taken from the corpse are placed in the bottom of the pit each to the upper, middle and lower portion horizontal!} Then the elder agnate of the deceased will throw *same* and *rai* grains three times into the grave from both the upper and lower side. The corpse is then taken by the affines holding on the four corners and is raised up and down three times and lowered into the grave with head part towards the south, thus facing northward. The corpse is laid in the grave in a sitting posture with legs folded and hands crossed across the chest⁹. Wooden planks will be placed above the corpse to avoid mud falling on the corpse. Then turning back, all of them put handful of earth into the grave three times after which the grave is covered. Small stones are heaped on the head portion as a mark for identification.

The roots of trees unearthed while digging will be gathered and heaped on either sides of the grave. They believe that these roots if not filtered out from the soil will create obstacle for the easy movement of the soul in and out of the grave. The bamboo bier will be dismantled and is kept on one side of the grave. Since the Mudugas believe that the deceased must have in the next world, his survivors are careful to equip him with all the necessary things like food and tools. A plate of *same* cake and a cup of water along with the small basket of grains are kept near the head portion on the right side. The plate, cup, and basket are slightly cut with a knife on one side before it (placed). For a man, a knife and for a woman, a hoe (*lova*) with its blade reversed and a small sickle (*kora kathi*) is placed on the right side of the grave. Polishing stone (*mimlikalika*) used by a woman will be buried in the grave along with the corpse.

After this, the *nigal km* *ekalavatu* is performed by a close and elder agnate. For this, the stem of a dry and a green *dhurlograss* are taken and then remembering the name of one of their ancestors, the dry stem is forced into the earth on the head part of the grave and is taken. This is then repeated with the green stem remembering the name of the deceased. By doing this, they believe that they bring along with them the spirit

(shadow or soul) of their ancestor and the deceased to the hamlet. Then all of them without turning back come out of the grave-yard and proceed towards the stream where they wash to purify themselves from pollution and return to the hamlet. They take the same route back to their hamlet without deviating.

While the men coming from the grave-yard (*chudala*) enter the hamlet, women and children keep away from their sight. Mothers are seen chasing away the children to the backyard of their huts to protect them from getting possessed by their ancestor's soul believed to have accompanied the men from the grave-yard.

In front of the deceased's hut, a wooden litre (*pod*) filled with water is kept by a woman who is a close kin of the deceased and all the men from the grave-yard come straight to it and see their shadow in the water. This is to confirm that their *nigal* (shadow or soul) has come back along with them without remaining in the grave-yard. Now the *nigal nokrathu* ceremony is performed by the elder agnate through which the soul of the deceased is introduced into the company of the ancestor (for detail see Chapter 1). After the *nigal nokrathu* is performed, the women who is closely related to the deceased come and spill the water from the litre on the ground and then weeping aloud she kneels, pressing her face and chest on to the wet ground and then walks back to the hut calling aloud the name of the deceased. By doing this they are inviting the soul of the deceased to the hut. During the funeral of Kaden's son Ramaswami of Thare-Abbannoor, the above ceremony was done by Kaden's present wife Poliche. Kaden's first wife Mallika who is the mother of Ramaswami though present at the funeral, did not have any right to perform the ceremony since they had divorced. But it was Mallika who had taken care of her son Ramaswami when he fell sick and was all through with him till his death. After the *nigal nokrathu* Kaden's present wife Poliche came and poured out the water from the litre, then knelt and pressed her face on the ground, and weeping aloud she walked back to her hut calling the *technonym* name of the deceased "Santhappo Santhappo". While this was done, Mallika was seen away from the crowd in a corner weeping alone.

On that day in no but sweeping is done and the ashes in the fearA be kept untouched. The sweeping is thrown to the backyard only after a day. The *nigal* of the deceased is offered food for seven days. In certain cases this may extend for more days.

This offering of food for the *nigal* of the deceased is fenem as *melse-hkratka*. At Thaze-Abbannoor when Radon's younger daughter died, offering of food to the *nigal* was done for about two months.

Thus conclude the funeral rites of the Mudugas and the relatives who have assembled will disperse except close kin who stay back for one or two more days.

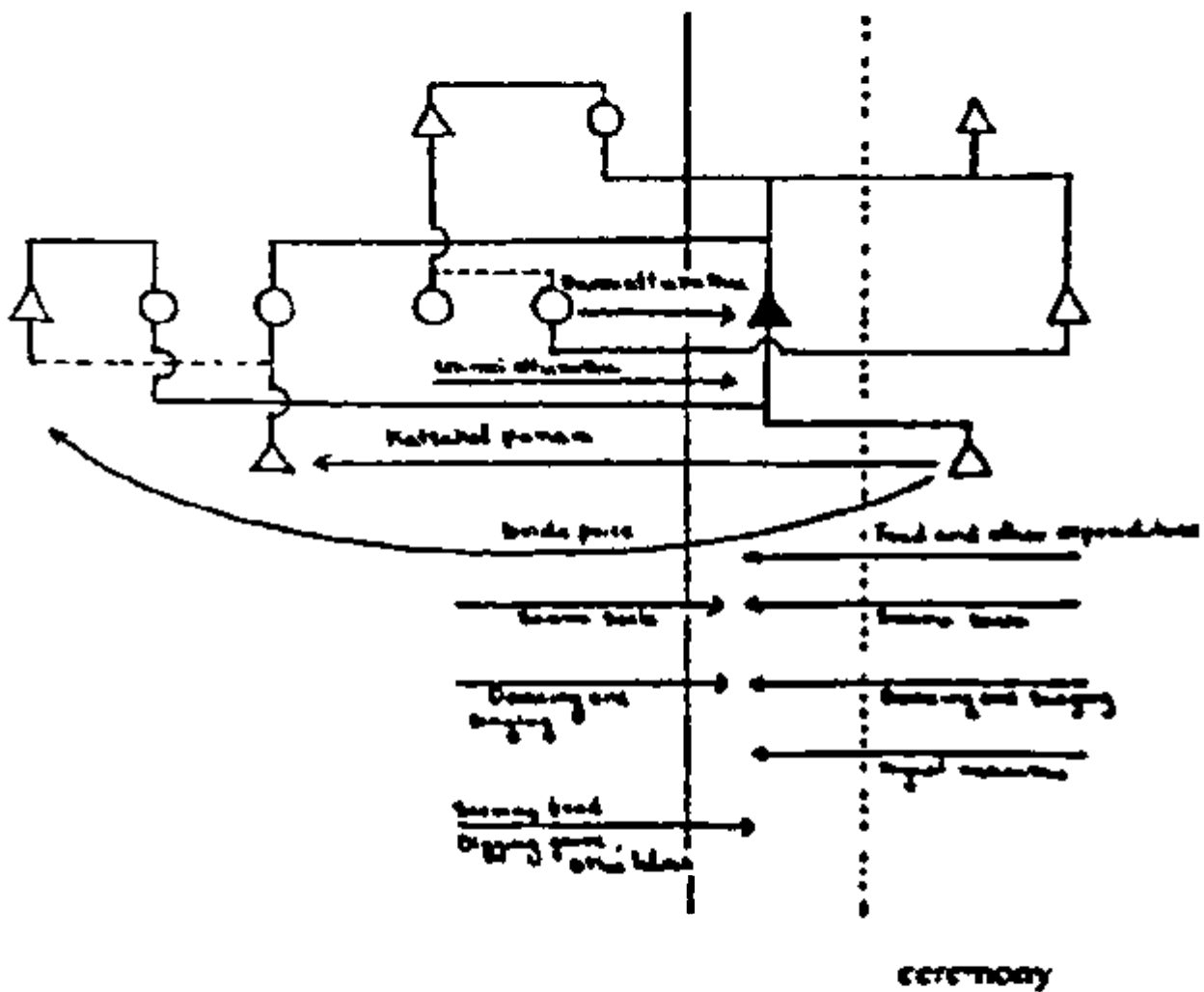

Fig. 7.8 Exchange relation during funeral

A living adult is believed to be composed of three different elements: the 'body' (*columpu*), the 'breath' (*kattor u ru*) and the 'shadow' (*argal*) and all these elements undergo transformation after death. Once the breath goes out from the body permanently, it results in death and through burial the body gets decomposed. But the *nigal* or soul after separating from the body remains till Dry funeral when it is incorporated into the world of ancestors. The freeing of the soul completes a soul cycle begun by 'naming'

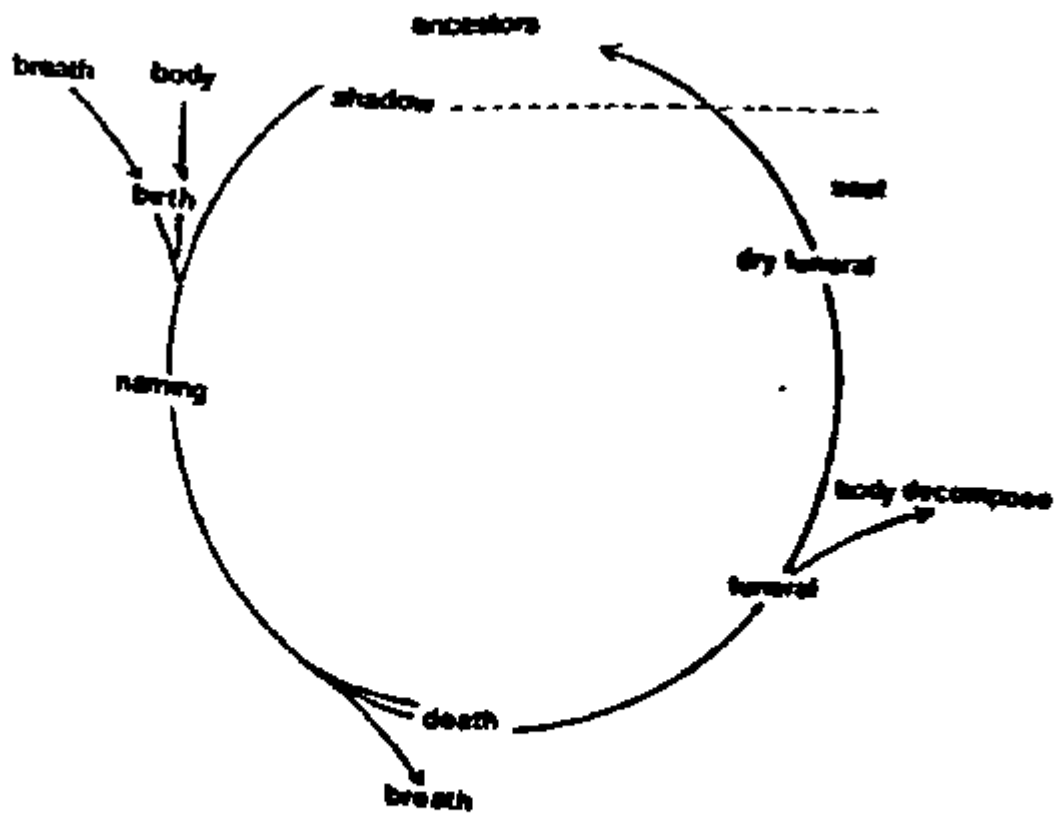

Fig 7 9 Soul-cycle

Dry-funeral ceremony.

Like all other life-cycle rituals, the funeral ceremony also consists of the elements of separation, transition and incorporation. However, the survey of death rituals by Van Gennep (1909) shows that it is the transitional or the liminal which dominates mortuary ritual and symbolism rather than the element of separation. He views funeral ritual as a transition that begins with the separation of the deceased from life and ends with his incorporation into the world of the dead. According to him, "The transitions have a duration and complexity sometimes so great that they must be granted a sort of autonomy" (1960 (1909) 146). People strongly believe that there is a transitional phase called "intermediary period" where the mortal is neither alive or fully dead (Hertz 1907).¹ The end of this period is marked by a great celebration during which among

the Mudugas, this intermediary period is clearly distinguished by separate funeral ceremonies,¹² first one is the actual funeral (*savu*), which takes place immediately after death, and the second is the dry-funeral (*hara savu*) done several years later during which the bones of all the deceased since last Dry-funeral are collected, and returned in a rock cave after performing several rituals. The length of the intermediary period may be prolonged by several factors, such as the need to accumulate a income/resources for the feast and moreover it is a collective ritual for the village. During this intermediary period, the grave-yard (*chudala*) is believed to be the abode of the formless soul (*nigal*) and at times visits the hamlet and usually feared by the people. The dry-funeral terminates this transitional period by honouring the dry bones of the deceased, confirming the soul's arrival in the world of ancestors and establishing the dead as an immortal ancestor. The division of funeral into two parts (double obsequies) separated by several years enable people to mourn the disruption of society, but later to reestablish its order. According to Radcliffe-Brown, "ceremonial customs are the means by which the society acts upon its individual members and keep alive in their minds a certain system of sentiments. Without the ceremonial those sentiments would not exist, and without them the social organisation in its actual form could not exist** (1964 : 324)

Thus funeral ceremonies should be examined its expressions within the social order reinforcing collective sentiment and social integration through formal pattern of behaviour and interaction and analyzed as rituals having symbolic significance and meaning within the conceptual level

Dry-funeral (*hara-savu*) or *seerui* is a grand memorial funeral being performed once in forty to fifty years when the bones of all the deceased agnates since the celebration of last dry-funeral, are collected and after performing several obsequies are reburied. All the relatives in the neighboring hamlets actively participate in these celebrations and may even include the *turumbas*

Prior to the actual celebration of dry-funeral, a preliminary ceremony called *kalluku rai-atrathu* (putting *rai* for the stone) is performed in the house of the *mannukaran* (priest). For this ceremony, the elderly affines (*thulu-kettu-mappulu*) living in other hamlets are invited, and it is they who perform the major role. This is not elaborately celebrated and only close relatives from neighboring hamlets are invited.

Dry *rai* grains ¹³ will be put into the grinding stone (*beesu kallu*) in the *mannukaran's* hut and the senior affines arrived from other hamlets together hold the stick (*kambu*) of the grinding stone and rotate it three times clock wise and anti-clock wise. While doing this, women gather outside the *mannukaran's* hut and wail aloud. Food prepared out of *rut* is offered to the ancestors. This grinding stone will be covered from them with a bamboo basket (*thekku*) till the end of the dry-funeral. All the elders gather together to decide and fix an auspicious day to conduct the dry-funeral ceremony. The affines will also have a say in this decision making. The agnates and affines equally participate in celebrating this ceremony and both have their definite roles, rights and obligations to perform.

Dry-funeral is a grand and elaborate celebration which lasts for about four days. On the first day *paccha-savu* ceremony is performed. This is performed for those deceased agnates who have been buried without any formal celebrations involving drumming, dancing and singing. They do believe that a person's dry-funeral or the *bara-savu* cannot be observed without formally performing his *paccha-savu* rites and hence it is done prior to the *bara-savu*. For this, the relatives of the deceased proceed to the grave-yard with dry *darpapullu* (a wild variety of tall grass, *Poa cynosuroides*) leaves made into a coil with a knot at one end symbolically representing the deceased. Reaching the grave-yard, they keep the grass on their respective relative's grave and pronouncing their name they take it back. All these *darpapullu* representing the *paccha savu* (corpse) of deceased relative will be taken together on a small bamboo bier called *kanil* and kept under the *goodagara* constructed in the centre of the hamlet. Women who are relatives of the deceased ones come in separate groups and wail sitting round the *goodagara*. Then the music of drum and flute starts and men and women dance round the *goodagara*. This ceremonial act of wailing of women in group and the performance of drumming, dancing and singing will continue for a major part of the day. In the afternoon, the *paccha-savu* along with the bier (*kanil*) is taken out from the *goodagara* and brought to a distant place from the hamlet and is put to fire after heaping dry *raigs* over it. The male relatives of the deceased then holding the burning *raigs* circles the burning *paccha-savu* three times. Among them, the affines (*macha mannu*) go in a clock wise direction, and after making three rounds place the *raigs* near the food part of the burning *paccha-savu*. These burning *raigs* are called *thalai kalli* (bread *raigs*). The

agnates (*anna-thampi*) go round in an anti-clock wise direction and place the twigs at the leg part. These twigs are called *kaal-kolli* (leg-twigs). Women and children are not permitted to go near the burning pyre, and will watch from a distance wailing aloud.

After the cremation of the *paccha-savu*, the *niggal nokruthu* ceremony will be performed which will be similar to that performed during death ceremony (see Chapter 1). The ceremony is performed for all the deceased for whom the *paccha-savis* held and through this the souls are introduced to their respective ancestor. This concludes the *paccha-savu* ceremony.

Now the preparation for the dry-funeral ceremony starts and for this, a huge elaborately built and decorated three to five stoned 'funeral car' called *gudikettu* with four corner legs and a long central pole (*naduthoon*) is constructed. The construction of this structure is mainly done by the affines and it is they who bring the particular wood for the central pole supplied by Thodukki hamlet.¹⁶

The bones (particularly collar bones - scapula) of their agnates who have been buried in other hamlets will be unearthed one or two day* prior to the celebration by a team of elders headed by the *mannukaran* and is brought to the hamlet. These bones covered in white cloth is kept inside a small conical structure under the *gudikettu*. After this, women will come in large groups and sit round the *gudikettu* and will wail aloud. Men and boys start dancing round the *gudikettu* accompanied by the music of drum and flute. Later women and girls also join and the singing and dancing will continue all through the night.

In the next morning, a procession led by *mannukaran*, *mooran* and other elder members of the hamlet proceed to the grave-yard accompanied by drumming. They take with them metal rings kept in a bamboo container near a tree on the way to the grave-yard. Reaching the grave-yard, they dig the grave of their respective deceased kin in search for their collar bones. If they fail to secure the bone, then they put the metal ring in the grave and pronouncing the name of the deceased will take it back representing the dry bone. After this, *urun ei atruthu* will be done by close affines. For this, a bale oil is taken in the right hand and after folding, the outside of the palm is touched to the bone and keeps the inner side of the palm to his/her own chest. This is repeated three times.

The bones are then washed and arranged on a small bamboo bier in white clothes which is placed under the *gudikettu*. The bones brought from other hamlets will also be grouped along with this. Once this is performed, an ordinary gun is fired signifying the completion of this ceremony known as *karipolai*, and is followed by loud wailing of women gathering round the *gudikettu*. The ceremonial aspect of wailing as an act of expressing emotions and grief reinforcing collective sentiment becomes more explicit during this dry-funeral.

Men and women start dancing around the *gudikettu*. While dancing and singing goes on, close relatives of the deceased, usually women, throw coins, tobacco, beads, grains, etc, upward walking round the *gudikettu* weeping aloud. Children and women struggle hard running round the *gudikettu* for getting these. However, the dancing goes on continuously. Dancing and singing accompanied by drumming continues all through the night till dawn.

On the third day by early morning the people will disperse for a short time. They again assemble after a gap of about two to three hours and women gather round the *gudikettu* and resume wailing. Dancing and singing accompanied by the music starts again and continues till noon. Simultaneously in another corner of the hamlet, arrangement goes on for the *panchayath* meeting. This is held particularly for settling the issues related with bride-price payment of the deceased when it is not paid or if any balance still remains. The bride's relatives will put forward the case by keeping a *dakshina* of Rs 1 ¼ along with betel leaf, nuts, beads, etc, to the *panchayath*. When all have placed their case, the deliberation starts one by one led by two persons, one as groom's *jathi* and the other as bride's *jathi*. The subsequent procedures are similar to the *panchayath* held during marriage or funeral (see p 26*30 chapter 4). In the deliberation, if the husband's group have been detected to be the defaulter, the *panchayath* will ask them to make the payment, and the agnates of the husband then pool the money and give it to the *jathi* who will then hand it over to the wife's people. If any case remains unresolved, their bones will not be considered for the subsequent ceremonies.

After the *panchayath* is over, the event of the 'coming of affines' so participate in dry-funeral is enacted and is followed by the important ceremony of 'goat smashing'. The affines (*machu-maman*) are the main participants of this ceremonial and oversees the

significance of the affines especially the sisters children's obligation and duties towards their mother's brother and also at the time of the latter's *bara-savu* ceremony.

For this, the affines with white turban tied round their head and holding an umbrella with a male goat in one hand and a bag of ten sir rice on the shoulder come in a row from about hundred yards away from the hamlet as if they are coming from a different hamlet to participate in the *bara-savu* of their mother's brother. They are formally received with the music of drum and flute and after entering the hamlet, they holding the goats in one hand and rice on their shoulder make three rounds around the *gudikenu*. The gifts brought by the affines are taken to the *mannukaru* hut and the goat brought by the senior affine (*thalai-mappilai*) is made to stand before the *karudavam* (ancestral god) installed in the *mannukarn*'s hut. A distinction could be seen between the close affines and the distant affines with regard to the gifts they bring. Unlike the close affines, the distant affines need not strictly bring along with them bag of rice, but only goats and they will not circle the *gudikettu*. The affines residing in the same hamlet are also obliged to offer goats, moreover, as gifts for the *bara-savu*.

Later all the goats are taken to a corner of the hamlet and the *mannukaran* sprinkles ritual water over them as sign of purification. Then holding each goat by two men on their legs and raising upwards over their shoulders with heavy shouting and howling they run towards the *gudikettu* and circle it three times. The goats are then made to stand under the *gudikettu* facing the bones, and an elder affine after a short prayer first hits the head of the goat brought by the *thalai-mappilai* with an axe. The skin and flesh on the head part between the ears of this goat is given to the *mannukaran* offering to the ancestral god. After this all the remaining goats are smashed one by one to death. Then the affines holding the blood stained axe, sticks, brooms, mud-pots and other household utensils in their hands dance round the *gudikettu*. Later, the goats are taken to a different place and butchered for cooking.

Simultaneously, men and women resume dancing and singing around the *gudikenu* accompanied by the music of drum and flute which will continue throughout the night. At night a grand feasting is arranged in which rice and meat is served to all who have gathered there for the *bara-savu*.

It is to be mentioned here that necessary arrangements will be made to supply rice and other provisions in the evening on all these four days for all those who have gathered for this elaborate function. One week before itself, they accumulate a surplus provision for the festival and the expenditure towards it will be met collectively by both the agnates and affines of the hamlet. However, the agnates are obliged to take the major share, and each household of the agnates should strictly donate a prescribed amount, whereas the affines residing in the hamlet contribute according to their capacity. The amount of rice supplied to the residents of the hamlet is called *veetu-padi* which is about two liters per household, and that supplied to the invited guest is called *vanna-padi* which may be about ¼ liter per person or one liter for three persons. Most of the people who have come from other hamlets get their rice cooked in any of their relative's hut and eat along with them. Others who are not having close kin in that hamlet may borrow utensils from any of the hut and cook themselves.

On the fourth day morning, the *gudikettu* will be taken from its place after offering a short prayer by the *mannukaram*, *moopan* and the affines who have constructed the *gudikettu* standing in front of it. At this time of departure all the women gather near and sitting round the *gudikettu* wail aloud and the entire hamlet will be with the sound of crying and wailing. Then the *gudikettu* will be lifted by the agnates on their shoulders and is carried out of the hamlet in a procession to be dismantled in a distant place. While the *gudikettu* is about to be taken out, the *a* (Tines enter and block the procession by holding back the *gudikettu*. They will retreat only when they are assured that a goat will be given to them later. This ceremony is known as *kattalupidukuthu*. Thus affines are given a female goat in return for the male goats they brought for the ceremony.

On reaching a little away from the hamlet near a mountain, the procession stops and the *gudikettu* is dismantled. The bamboo bier on which the bone was kept will be burnt by heaping dry twigs over it and the bones wrapped to white cloth is rotated above the fire three times by the *mannukaram* and is kept between the branches of a nearby tree. The agnates and the affines will go round the fire with burning rings, and the similar procedure done during the cremation of *poorhu-soru* will be repeated. After this, the procession returns to the hamlet where a *pakkalam* is fetid to distribute the remaining

provisions and meat. The elder members of the hamlet will fix a reasonable rate for the meat and rice and it will be distributed out for the relatives who are gathered there. The money collected from the *pakkalam* will be shared equally among the members of the hamlet. With this, the major ceremonies associated with the Dry-funeral comes to an end and the relatives gathered there will disperse by afternoon taking their meat and provisions.

After about seven days, the special ceremony of 'burying the bones' will be performed. But one day prior to this, the ceremony of 'collecting *nigaal-kallu*' (shadow-stones) is done. For this, a procession led by the *mannukaran* and other elders move towards the near by *Bhavani* river to a particular place called *nigaal-kundu* where they perform the ceremonial collection of *nigaal-kallu*. Here, they pronounce the respective name or kinship term of their deceased thereby watching closely the water-worn stones under the running water. Now when they see a particular pebble moving immediately after a name has been pronounced, that stone is taken believing it as representing their deceased one or being possessed by their deceased one's soul. After collecting the *nigaal-kallu*, they proceed back to the hamlet and keep the water-worn stones near the hamlet in a particular place.

On the next day, along with the bones and the *nigaal kallu*, the elder agnates of the hamlet and senior affines will proceed to the *gobbe* (small rock-cave) situated away from the hamlet in the forest. Half way from the hamlet, at a particular place they stop and *same soru* (a dish made of same) and chicken curry are prepared, which is offered to their ancestors in front of the *gobbe*. After that, the bones are kept inside the *gobbe* and the *nigaat'kaiiu* are arranged outside near the mouth of the *gobbe*. While doing this they take extreme care so that no shadow (nigal) of any one of them fall inside the *gobbe* since they believe that it may result in their death. This 'second burial' of bones shows how the agnates even though dispersed in other lands are abstracted out and finally incorporated into the 'world' of ancestors depicting their deep rooted agnatic ideology. After this, they come back to the place where the preparation took place and *same soru* and chicken curry is served for the affines. Since this food is usually associated with the 'keeping of stones' it is called *kallu-bettison*. And moreover since it is served mainly for their affines 'sister's son/ son-in-law' (mappulal) as a counter presentation for the

sen rice they have rendered during *bara-savu* of their mother's brother, it is also called *mappilar soru* (affine's rice). This concludes the entire ceremony associated with *bara-savu* or dry-funeral of the Mudugas.

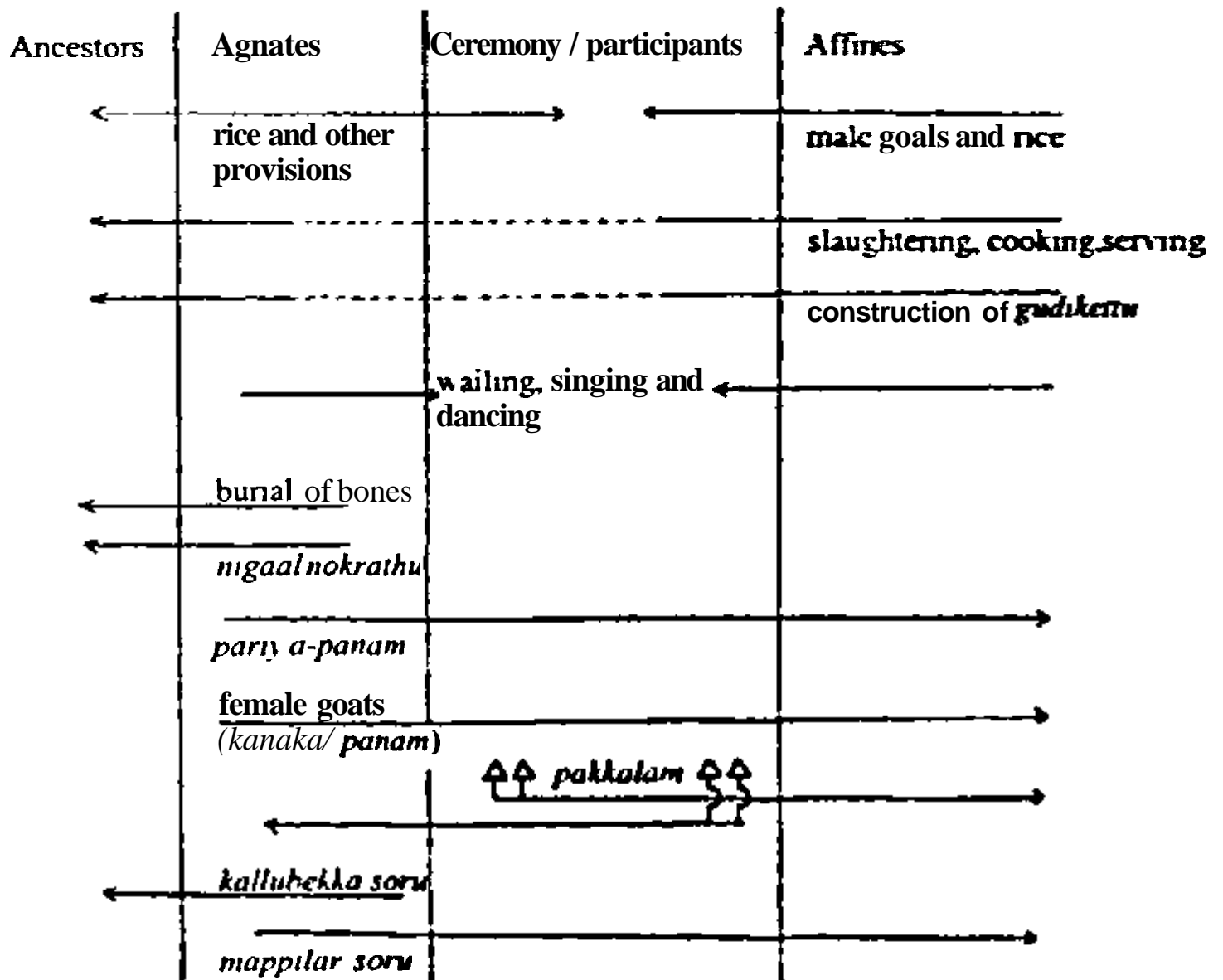

Fig 7.10 Exchange relation between agnates and affines during dry funeral

Analysis of these funeral rites shows that almost funilar ceremonies and ritual procedures are earned out in all the three phases-death, green-funeral and dry funeral, and the evenu mainly consist of the display of the deceased, honouring of the deceased b> drumming, singing and dancing, the burial of the deceased and fiaalJy assimilating the deceased into the world of ancestors. The Dry-funeral or *bara-savu* is considered as the most important and most elaborate event in Muduga social life depicting the rights and

obligations of, and the transactions between agnates and affines. The death and burial are sudden and unplanned, but dry-funeral on the other hand are prepared, organised celebrations that are determined.

The above description of ritual prestations and rights and obligations of kinsmen associated with the rites-of-passage depicts the nature of Muduga social structure by describing the value they place upon consanguinity and affinity. These roles and obligations clearly shows that the Muduga social relations are a combination of consanguineal (agnatic)and affinal relations, and a structural difference is always maintained between the agnates and affines in their behaviour, roles and duties towards each other. The characteristics of this social structure is being generated from culturally defined strategies for bilateral affiliation and marriage alliances which insure social and economic security. Thus through the mechanism of prestations relating to different ceremonial and social events, Mudugas retain affinal networks which are reproduced with each new marriage. By maintaining this exchange relationships, the affinal relatives are brought into the closer circle of kin ensuring unity and cohesion.

In such a system of alliance and affinity, roles and relationships, as Dumont (1984) says, have permanence. While groups may fluctuate, change or vanish. These prestations, roles and obligations are not only the product of alliance relationship which shows the significance of affinity, but also the catalyst that sustains kinship ties. The gifts and obligations associated with marriage, funeral ceremony, and dry-funeral, etc., serve to intensify the importance of prestations, and the value of alliance relationship. However, the rights and obligations associated with these life-cycle rituals are not affinal alone but a combination of both affinal and consanguineal. It is important also to note that these payments or gifts are not restricted between two immediate families, but it is shared within the larger network of relationships as a reminder that it has significance beyond the individuals within a particular alliance.

From the point of view of ceremonial exchanges and sharing, there are two categories of gifts or prestations. The first one often takes place between two families or between two groups and the second one within each of the two groupings. Out of these two modes of exchanges, one is the local mode of exchange depicted through the propitiation of ancestors and the rights and obligations among agnates. The second one is

the lateral exchange through alliance and the attendant set of **compensation payment**. In the external realm affinal exchanges unites **exogamous** descent group through the exchange of goods, services and **payments**. In the internal realm, the **sharing of food and labour**, the pooling of money as well as the distribution of **bride wealth** defines the boundaries of descent group through the contrast between sharing and exchange.

The Mudugas extend considerable effort to keep an alliance going into the **next generation**. Even if the gifts or payments are not paid or counter **prestited** in a particular generation, the children who are in the next generation continue as **exchange** partners of their fathers. After one's parent's partner have **died**, the **gift or prestation** relationship will not break, rather the children take responsibility to extend **this** relationship. **This** could be clearly viewed in the case of **bride-price** payment where a son is obliged to **pay** the *pariya-panam* of his father after his death. **Similarly**, a brother's son will have the right to claim the bride-price of his father's sister in the absence of his father.

Although most of the prestations and counter **prestitutions** take place at the level of **kin** groups, the rights and obligations associated with **rites-of-passages** are essentially between persons of definite **kin** categories belonging to **affines** and **agnates**. Among all these relationship, the right and obligation between MB and ZS is the most crucial one observed. It stresses the maternal uncle's role and the sister's son's obligation in ceremonial occasions like marriage, funeral, dry-funeral (*seeru*) etc. **This pre-eminence** of maternal uncle can be understood very well from the alliance perspective and the diachronic affinal significance of maternal uncle. If suppose ego has not yet married, his maternal uncle is his closest **affine**. He is both the person who gives him presents on most ceremonial occasions and his potential **father-in-law**. If the ego is married according to the rule, the maternal uncle is also his **father-in-law**. Finally if ego has married differently, even then the affinal importance of his mother's brother remains. Thus in all the three situations, the maternal uncle's prominence **** evident** from the alliance perspective.

The maternal uncle remains as maternal uncle and his right and obligation continues. The maternal uncle is distinct from other relatives because of special and more important gifts and also because of definite **ceremonial functions**. The characteristic specific to the relationship of MB and ZS is that it is **affinal** and at the same

time exhibits generational difference, and more over this relationship takes on a diachronic dimension. The maternal uncle's role, which is based on affinity or **alliance**, as Dumont (1986) says, owes its importance to the fact that it contains alliance in a genealogical form : not only 'synchronic alliance*' but also 'transmitted alliance*.

NOTES :-

- i. Van Gennep (1909:66-67) makes distinction between physiological puberty and social puberty differentiating puberty rites from initiation (marriage initiation) rites which in most societies rarely coincide. Since marriage takes place one or two years after puberty, * physical puberty* precedes *social puberty*.

- 2 Menstruation is considered as a period of inconvenience and interruption from normal life. A menstruating girl is restricted from the kitchen of the hut and is secluded in a corner of the *dheeti* for about seven days. She cannot touch the vessels and approach the cooking hearth. To others she reveals her state of pollution by saying "nanu koorel ille", meaning 'she is out from the kitchen'. She is forbidden to engage in productive occupations of sowing or harvesting, but may do other farm work and also go out for collecting fire-wood. If the husband is a man of ritual importance such as *mannukaran*, agricultural ceremonies and other rituals may be postponed till the pollution is over. On the sixth day, she takes a purificatory bath, washes her clothes and all the household vessels and resumes her normal state.

- 3 *Kauri* tree- *Helecteres isora* of *sterculiacea* family, is considered ritually important by the Mudugas and are used for religious purposes. They believe that their ancestors have used it to make digging stick (*kauri bayi*) which was their main tool and even now Mudugas prefer to make digging stick with the trunk of this tree.

- 4 There are various occasions at which the Muduga women carry out wailing.
 - a) During funeral ceremony they wail sitting round the corpse.
 - b) when two relatives meet for the first time since the death of a close relative of either of them, they embrace and weep together.
 - c) when visiting a deceased relative's but for the first time since his/her death whose funeral ceremony was not been able to attend.
 - d) during Dry-funeral, when bones are kept under the *gudilera* women perform the ceremonial wailing.

5. There are various types of funeral dances performed by the Malagas of Anappach such as, *parivatu, malavatu, ootavatu, dillavatu* etc.

6. Yalman (1967), David (1973), and Good (1981) report this term for the Sinhalese, the Jaffna Tamils and the Kondaiyan kottai Maravar respectively-
7. See Note.3
8. Regarding the sitting posture of the **corpse**, there is a **widely** said myth **among** the Mudugas. The myth says **that**, once four brothers (believed to be their ancestors) traveled towards the four **sides** of their **village** to understand the distance of each **side**. Thus one went to the northern **side**, other **to** the south and the last two towards the east, and the west respectively. After few **months**, **all** the three **who** went to the **south**, east and west returned knowing the distance of their respective side **But**, the one who traveled towards the north **did** not **return**. The three brothers sitting under **a** tree started **waiting** for their brother's return by looking towards **the** northern **side** **But** even **after** years he **did** not return and the three brothers sitting **like** that with **legs** folded, **died** one after the other **Thus**, as a mark of respect **towards** those ancestors and for their **memory**, Mudugas bury their dead ones in a sitting posture **with** **legs** folded
9. Even if a soul (*ntgaaf*) **is** separated from the living and introduced **into** the company of **ancestors**, incorporation **into** the '**world** of ancestor*' takes place **only** **after** the dry-funeral **Till** then their abode **is** the **grave-yard** and are believed to visit the close relatives **in** the hamlet by itself
10. De coppet (1981 : 175-204) summarized Hertz's main conclusion as
 - i) death **is** not felt as an instantaneous destruction of an **individual** **t** life
 - ii) death **is** rather to be seen as a social **event**, the starting point of a ceremonial process **where** by the dead **person** becomes an ancestor
 - iii) death **is** like an initiation into a **social** after life making **it** a kind of rebirth.
(referred in Palgi and Abramovich, 1984 385-417)
11. Double funeral are often linked to the **opposition** of bones **to** the **flesh**, i.e. the dry transcendental elements of the **skeleton** as opposed to the **wet** or **temporal** elements of the flesh.

12. This *rai* grains used for the ritual is treated with **extreme** care. It should not be plucked from the plant and dried in the sun. It should remain in the plant itself and get dried up.
- 13 The word *savu* has related meanings like **death**, funeral and also corpse. The word *paccha*, has two meanings, green, and raw or **wet**. Here, the word *paccha* is used in the latter sense.
14. This is a miniature form of the bamboo bier (*kattul*) made for keeping corpse during the death ceremony.
- 15 The construction of *goodagarais* exactly similar to that which is constructed during the death ceremony.
- 16 The Thodukkı hamlet supply this wood from a particular tree called *oanelmaram* (?) for all the Muduga and kurumba hamlets and also for the Todas of Nilgiri
- 17 There are different views regarding the belief system associated with the *nigaalkallu* among the tribes of Nilgiris and surrounding area. Anantha Krishna Iyer/Bala Ratnam (1961 : 177) hold that "the spirit of the deceased . . . is supposed to dwell in the pebble," whereas Noble (1976 : 120) says that "there is no positive identity of stone with the departed spirit" but later described them as being "related to spirits of the departed" (1989 : 44). Citing these views, Kapp, D B (1985 : 501) says that, the one given by Anantha Krishna Iyer/Bala Ratnam represents the most correct one, though not satisfactory
- 18 This rock cave or *gobbe* where bones are kept is referred to as 'dolmens' by D B Kapp(1985)

CONCLUSION

The Mudugas are a small little known scheduled tribal group inhabiting the Attappady area of Palakkad district in north Kerala. They are distributed in about 21 hamlets called *Ooru*. The basic unit of Muduga social organization is the patrilineal clan known as *koottam*

The Muduga residential settlement called a hamlet or the *ooru* is associated with a particular clan or *koottam* whose ancestors were believed to be the original inhabitants of the land. Although, a hamlet is considered as the traditional land of a particular patrilineal clan, a hamlet is not always composed of a particular descent group alone. Though the notion of agnation through birth forms the basis of descent membership, local groups or hamlets are not restricted to agnatic descendants only. Affines and non-agnates from other clan become established co-residents, build huts, clear land, cultivate and participate in the life of the agnates of the hamlet.

In common day to day context, reference to clan or descent group is rarely made. The people tend not to concern much with the nature and role of their descent groups in their daily affairs. Most of the young generation are not aware of their descent group and cannot state specifically the descent group of their affines, nor are they concerned to do so. Among the Mudugas, marriages are often devoid of elaborate ceremonies, and bride-price need not be strictly paid at the initial stage itself, but are free to pay at a later stage. Moreover, with regard to marital union, kinship terminology and system of kin categorization play the crucial role rather than descent group.

These factors give the impression that Mudugas seem to be different from a strong patrilineal system of the ideal type. But the deeply rooted patrilineal ideology subtle in the system, forms the fundamental basis of the Muduga social organisation. The rules or ideology will not be always congruent with practice and cannot be observed in all cases.

Though affines are recruited as co-residents, even after generations the ties of co-residence will not be converted into ties of descent, thus treating identity through locality and identity through descent as independent of each other. Thus affines remain affines

and will never be assimilated or incorporated into the agnatic fold during their life time. This fundamental opposition between agnates and affines forms a basic principle of Muduga kinship.

Even if agnates are distributed in other hamlets, they are never lost permanently for the clan. They are brought back to the natal land in course of time at different stages :

- a. A man, after a period of 3 –5 years of bride-service in his affines hamlet will return to his natal land with his wife and children to live along with his agnates.
- b. Or else in his old age returns to his natal land so as to die and get buried in his natal land.
- c. Or after death, the body is brought back to the natal land and buried.
- d. Or finally, during dry-funeral (*bara-savu*) the bones of their agnates who got buried in other hamlets will be collected and taken to the natal hamlet for the second burial along with the bones of other agnates.

All these factors clearly show how the agnates even though dispersed in other clan lands are abstracted out and finally incorporated into the 'world' of ancestors which depict* their deep rooted descent ideology.

After the patrilineal *kootam*, it is the family that constitute the most discrete social grouping among the Mudugas. It is the family which always takes the form of a household functioning as the domestic unit. The day to day activities of the Mudugas operate at the level of the family or household. Nuclear family household is the prominent type among Mudugas. However, members other than the nuclear family also form part of a household giving rise to different types of family household. Various demographic, social, economic and ecological factors have an impact on the composition of household.

The basic requirement of * Muduga household is the co-operation and sharing in domestic activities by a man and a woman. However children also assist their parents in various activities giving rise to a sex-wise and age-wise division of labour. It is not only the members of a household that co-operate and share labour and food. Households of primary kin enter in a regular storing of food. These food sharing households are called *beethakarar*. They are usually the households of primary relatives of either the husband or the wife. It is the households of this *tenkH&rar* unit which always co-operate and interact

together and share labour and food. Depending on the extent of kin relation, there exist different spheres of co-operation and sharing ranging from the basic unit-household, to the wider unit-hamlet.

The two-section framework of Muduga kinship terminology divides the entire relatives into two, the agnates (parallel relatives) referred as *anna-thampi* and the affines (cross-relatives) referred as *macha-maman*. The fundamental opposition of sharing and exchange-sharing among the agnates and exchange between affines, form a major aspect of Muduga Social structure. Thus between affines there is exchange of women, bride-price, goods and service. The agnates share among themselves food, land, labour and above all the sharing of agnatic substance. The perpetual flow of women across clan is reciprocated by the flow of goods, service and bride price in the opposite direction and this process is diachronic in nature. Thus the opposition between sharing and exchange represents the dual dimension of social reproduction internally through the perpetuation of a shared identity and externally through the exchange of reproductive assets

The kin terminological system and the cross-cousin marriage rule embedded in it itself regulate marital union and other associated behaviour pattern. The terminological system would also be perfectly permissible from the view point of descent exogamy though the knowledge of descent groups are often secondary with regard to marriage union. That is, they give preference to category rather than group. The Mudugas have bilateral cross-cousin marriage rule. A man is prescribed to marry a woman of the category *attai* and a woman to marry a man of the category *machan*, the category that includes bilateral cross-cousins (FZD/FZS and MBD/MBS). Within this category of cross-cousins, no preference is expressed to either paternal or maternal side.

The sharing of food and labour and co-operation in domestic affairs between a male and a female is the basic feature of a Muduga mimed life. According to tradition, there are no ceremonial events which bridges pre-and post-marriage status among the Mudugas. Rather, marriage crystallize as time passes, children and other indices accumulate, bride price is paid and the community recognizes the marriage and the couple so presents themselves to the society.

The exchange of bride-price initiates a series of prestations to be exchanged between the two groups united by affinal links. The establishment and continuation of

affinal ties between descent groups are more significant and conspicuous and are governed by a set of well defined obligations, roles and prestations between the affines and consanguines on various occasions. The most outstanding and significant of these relationships are seen between the mother's brother and sister's children and also between cross-cousins binding the affinal families and their respective group in an alliance tie. The importance of mother's brother can be seen during all life cycle rituals of his sister's children where he is given utmost importance.

From the ethnographic description it is evident that the actual practices of Mudugas appear to deviate from an ideal patrilineal type exhibiting bilateral tendencies which are not characteristic of a strong patrilineal society. The alignment between mother's brother and sister's children are very strong and they do engage in wide-ranging reciprocal exchange with maternal kin and affines reducing the prevalence of corporate groups based strictly on patrilineal kin. Rather than completely ignoring the filial relation between mother and children, they consider the matrilineal link as complementary to the patrilineal link and the 'agnatic substance'¹ transferred from father to son. Moreover, in regulating marital union, kin terminological categories play major and important role than the notion of lineal exogamy. Among Mudugas, the women retain relationship with their natal group, and are not cut off even after marriage. They are incorporated into their husband's descent group only after their death.

Among Mudugas, often noted is the practice of a delayed bride-price payment. Bride-price, which initiates a series of exchange between two official groups, need not be strictly paid at the time of marriage. They are free to pay it in a later stage. However it cannot be concluded that among Mudugas there is no strict and firm rule regarding bride-price payment. The strong underlying rule of reciprocal exchange functions in such a way that no marital union can escape the transaction of bride-price. Though not at the time of marriage, but later at the death of either of the spouses or even at a later stage during the funeral, the bride-price had to be paid by the agnates, failing which the bride's group is denied right in the wife's bone and will not be assimilated into his group.

Payment of bride-price ensures the transfer of right in the woman's labour right to her sexual services, right in her body and bone after death, and above all bride-price payment transfer the right in the children to her husband's group. Thus it is not only the

wife's kin who are particular with the bride-price. But the husband's kin group are also more particular in paying this debt and taking the right of the children.

Marriages cannot always occur between cross-cousins (real or classificatory) only. However, the newly formed affines through relatives related by non-kin marriages are assimilated into the correct terminological frame work as if the union had occurred between cross-cousins. The relationship they create supersede those existing before hand and they manage to address one another using kin terms which are applied logically and consistently. Hence, union can be treated as "wrong" only in the behavioural level or in practice, but not in the prescriptive sense.

The basic confusion with regard to cross-cousin marriage forms is that which tends to mix up two entirely different phenomena. That is, a preference for marriage with an actual first cousin as against other cross-cousins, and a prescriptive rule which requires that only women of one particular category of relative may be considered legitimate spouse. Among the Mudugas, a male may legitimately marry any female of the category 'affinal'. It has been a 'regrettable convention', as Leach (1962) says, to translate classificatory kinship categories by the closest genealogical denotata. The main error lies in the attempt to explain the rules by assuming that prescription is in fact concerned with marriage with real cross-cousins. In a bilateral cross-cousin form, a clear distinction between mother's side and father's side cannot be reached since person related through father occupies the same kin type position through mother, as a bilateral relative though the genealogical nearness vanes. Thus when a person marries his *mama**'s (MB) daughter, real or classificatory, in the prescriptive level he is also marrying his *mami*'s (FZ) daughter.

If the principle of descent provides the diachrotue anchor to the relationship within the descent group, it is the rule of bilateral cross-cousin marriage and the concomitant kin terminological frame work that provides the diachronic scope for the affinal relationship to be continued between the descent groups from generation to generation. Though this is true at the ideological level, the transmission of affinal alliance does not operate in the same perspective fashion as it is seen in the case of descent and the relationship within the descent group at the empirical level.

It is observed that the affinal relation and the associated interpersonal obligations and prestations operates at the level of affinally related families. The circle of affinal

relations changes with change in the line of alliance and **this affinity is** hardly more than marriage and have a synchronic nature. Nevertheless, the terminological structure **would** be perfectly congruent with repeated bilateral **cross-cousin marriages depicting** affinity as being transmitted continuously from generation to generation **between two groups giving a** diachronic nature.

The fundamental opposition of **sharing** and exchange sharing among the agnates and exchange **between affines**, forms the **basis of Muduga kinship organization**. One is the lineal mode of exchange depicted through the propitiation of ancestors and the rights and obligations among agnates. The Agnate share among **themselves food, land, labour and** above all the sharing of **agnatic substance**.

The second one is the lateral exchange through **alliance** and associated **obligations** and payments. The exchange of women across clan is reciprocated by the **flow of goods, service, and bride-price** in the opposite direction **which** takes a diachronic nature. Thus the opposition **between** sharing and exchange represents the dual dimension of social reproduction internally through the perpetuation of a shared identity and externally through the exchange of **reproductive** assets.

There exist a certain degree of inconsistency **between** the actual practice and the rule in every aspects of Muduga social system. These elements of inconsistency do not lead to the disintegration of system but are actual elements of Muduga kinship **which** are inevitable in practice. Thus rules do not correspond exactly to behaviour but exist **in order to regulate** it, to set limits upon it. The **patrilineal** ideology functions as an underlying **implicit frame work which** holds back and legitimise **the elements** of disorganization and encompass the range of practices **within** the fold of the **system** maintaining a structural **continuity**. This nature of the Muduga society can be **well understood** only **by** a meaningful **linking** of the ideal and the actual through the **interrelationship** between structural premises **and the** ground reality.

GLOSSARY

This glossary contains native words appearing in the thesis with the **exception** of km terms (see Table 5.1; 5 J; 5.4) and names of hamlets and descent groups (see Chapter 3). Most scientific **identifications** of plants and animals are found in Chapter 2. **The** meaning of almost all the native words are given in the glossary so as to contribute to the **better** understanding of the **ethnography** of the **Mudugas**.

<i>aadyam</i>	- first
<i>aanel maram</i>	- a variety of tree whose trunk is used to erect the central pole of the gudikettu
<i>aanu (aan)</i>	- male
<i>aaru</i>	- who
<i>aarum</i>	- will reduce
<i>adishi</i>	- cooking and eating
<i>agarishu</i>	- made to cry
<i>akanna</i>	- distant
<i>alagu</i>	• rafters made of bamboo splits for roofing
<i>alai</i>	- watch-hut
<i>alan</i>	• husband
<i>amme</i>	• term of address for younger female child
<i>appu</i>	- then, if so
<i>aruvu</i>	- god of hunt
<i>athu</i>	- that
<i>atta</i>	-leech
<i>attrathu</i>	• topour
<i>ayyan</i>	- term of address for younger male child
<i>baji</i>	- digging sack
<i>baka</i>	- plantain

<i>bakanju bachineru</i>	- have fenced
<i>bala / vala</i>	-bangles
<i>balarthine</i>	- brought up
<i>ballia</i>	-big
<i>bandari</i>	- One of the hamlet council members assistant to headman
<i>bandaru</i>	-young boys
<i>bankilamme</i>	- we will receive !
<i>bankrathu</i>	- to receive
<i>baradt</i>	-sterile
<i>barasavu</i>	-dry funeral
<i>barasavu</i>	- dry-funeral
<i>basha</i>	- language
<i>bayasattu</i>	- attained puberty
<i>bayasikku banthathu</i>	- coming of age
<i>bayasu</i>	-age
<i>bedom</i>	-want
<i>beethe karar</i>	- households who enter in regular sharing of food
<i>bekkaruthu</i>	- should not keep
<i>bekrathu</i>	- to keep
<i>bele</i>	-service
<i>bere</i>	-different
<i>betha ideel</i>	- sowing
<i>bethe</i>	- seed
<i>bettadom</i>	- should clear cut
<i>bidum</i>	- will leave
<i>byju</i>	- an evil spirit
<i>binjivan</i>	- trap made of long bamboo bent Lie a bow , in which the animals get hanged .
<i>bitta</i>	- the large center beam resting on two poles at either end
<i>cheetha</i>	- bad
<i>chembila</i>	- leaf of taro (colocassia place)

<i>chonthakurar</i>	- relative
<i>chora</i>	-blood
<i>chudala</i>	- grave-yard
<i>dakshina</i>	- an initial offering
<i>davil</i>	- cylindrical wooden drum with leather on both sides
<i>d̄harphā</i>	- a wild grass used for rituals (Poa cynosuroides)
<i>d̄heetti</i>	-verandah
<i>dillattu</i>	- a type of funeral dance
<i>ecche</i>	-how
<i>edukirathu</i>	- to take
<i>edukkirathu</i>	- to take
<i>eduth odi rathu</i>	- to elope
<i>eenku</i>	- here
<i>eenthu</i>	- cycas tree
<i>elavu</i>	-debt
<i>ellu</i>	- bone
<i>ellupanam</i>	• bone price
<i>emma</i>	- we
<i>enakku</i>	- for me
<i>ennu</i>	- mine
<i>ethadom</i>	• should reach
<i>gali</i>	• an evil spirit
<i>gobbe</i>	- rock-cave for second burial
<i>goodagara</i>	- rectangular structure to keep the corpse structure made of four plantain at four corners and covered on all four sides and above with saree
<i>grashi</i>	• small bamboo loft tied above the hearth for storing grains and other small provisions
<i>gudikettu</i>	- huge elaborately built and decorated three to fit* stoned funeral car for the dry-funeral
<i>gulume</i>	- large bamboo basket for storing dry grass

<i>idi</i>	-thunder
<i>idurathu</i>	-putting
<i>idurathu</i>	- to put
<i>irrikkum</i>	- will remain
<i>irunthal</i>	- if having
<i>jammam</i>	- natal land
<i>jathikal</i>	-affines residing in an hamlet who also acts as third-man in cexemonial occasions mainly bnde-pnice payment
<i>jerry</i>	- a type of bangle made of copper
<i>kadame</i>	• responsibility
<i>kadesht</i>	- final
<i>kadu</i>	- farm land
<i>kadukkan</i>	• ear-ring worn by male
<i>kai</i>	• hand
<i>kaithatrathu</i>	• to tap the hand
<i>kala maru</i>	• broom used for sweeping the front-yard , the plant <i>Sida acuta</i>
<i>kalam</i>	- front-yard, central space in a hamlet
<i>kalayadorn</i>	• should give up
<i>kalyana murai</i>	- marriageable category
<i>kalyanam</i>	• marriage
<i>kammal</i>	• ear-ring worn b> female
<i>kanji</i>	- gruel
<i>kanni</i>	- snare made of metal wire or wild vine
<i>kannu</i>	- bull
<i>kara</i>	- a thorn) plant
<i>karadiattu</i>	- a type of funeraJ dance
<i>karanam</i>	•reason
<i>kari</i>	• meat
<i>karikadu</i>	• burned field
<i>karu darvam</i>	• a general terra used by the tribal people of Auzappadi to refer their

<i>karuka pullu</i>	- a variety of small grass
<i>kāthari</i>	- a cutting trap made of bamboo
<i>kathi</i>	- knife
<i>katta</i>	- bamboo; (funeral bier made of bamboo)
<i>kattakaal</i>	- leg part of the funeral bier
<i>kattam</i>	- stage
<i>kattil</i>	- funeral bier
<i>kattu not</i>	- disease through evil spirits
<i>kattu</i>	- malevolent effects caused by witches or evil spirits
<i>kauri</i>	- a tree of ritual importance (<i>Helecteresusora</i>)
<i>kettiyavan</i>	- one who tied
<i>kodi</i>	- white cloth
<i>kodiberu</i>	- first pregnancy
<i>kolli</i>	- twigs
<i>konkan</i>	- local term for Tamils
<i>konte</i>	- knotting of hair
<i>koorai</i>	- hut (kitchen)
<i>koottam</i>	- descent group
<i>kootti Pidikirathu</i>	- to hold together
<i>kortka</i>	• comb
<i>kothu</i>	- hoe
<i>krishi</i>	- cultivation
<i>kudam</i>	- base of a plantain
<i>kudi</i>	- household
<i>kudiyā</i>	- hearth
<i>kudukku</i>	- snare made of metal wire or wire toe
<i>kudumbakarar</i>	- close agnates
<i>kulam</i>	- term for the larger patrilineal descent group i.e. a class cluster
<i>kundu</i>	- pit
<i>kunthali</i>	- hoe
<i>kuruthala</i>	- assistant of bea

<i>kuyal</i>	-flute
<i>maadu</i>	- cow
<i>malayattu</i>	- a type of funeral dance
<i>Manji pattan</i>	- the ancestral god of Thaze-Abbannoor
<i>mannu panam</i>	- land price
<i>mannu</i>	- earth soil
<i>mannukaran</i>	- man of Land (priest)
<i>mappilai</i>	- male affines (son-in-laws brother-in-laws)
<i>maram</i>	-tree
<i>mari</i>	- changed
<i>masam</i>	- month
<i>mathilu</i>	- kitchen hearth
<i>mathiri</i>	- like
<i>mattayan</i>	- cattle herder
<i>mattu</i>	- food offered to the ancestors
<i>melse bekrathu</i>	- offering of food to the soul (<i>nigaaal</i>) of their dead ones
<i>-me</i>	- an affix used to address females of the same age group or young to age
<i>michi</i>	- nose stud nude of gold
<i>minnal</i>	- lightning
<i>minukku kallu</i>	- polishing stone
<i>mooku</i>	- nose
<i>moonathavan</i>	- third man
<i>moonu</i>	-three
<i>moopan</i>	- head man
<i>moopu</i>	- the position of head man
<i>mothakadavu</i>	- a place near Kadukumammu basket where a variety of paddy believed to be having some mental quality > its grown
<i>mudikkuvu</i>	- will perform
<i>muduguthu</i>	- loud echoing sound
<i>mulikipokuthu</i>	- to overflow

<i>mullu</i>	- thorn
<i>mundu</i>	- white cloth
<i>munnooru</i>	- three hundred
<i>munthu</i>	- firstly
<i>murai</i>	- kin category
<i>muthal</i>	- initial ; first
<i>nadappu</i>	- life style
<i>naduthoon</i>	- central pole
<i>nalamai</i>	- in a good way
<i>nalla</i>	- good
<i>nangadam</i>	- should avoid
<i>nangrathu</i>	- to avoid (keep away)
<i>nation</i>	- brother
<i>nattu not</i>	- disease due to natural causes
<i>navam</i>	- issue norms, etc
<i>nendu</i>	- crab
<i>nenjil</i>	- in the heart
<i>neppillatha</i>	- senseless
<i>neram</i>	- day
<i>nigaul</i>	- shadow
<i>ninakku</i>	- for you
<i>ninnu</i>	- yours
<i>nirantha</i>	- filled or loaded
<i>njeringu u</i>	- very close
<i>nodi irunthe</i>	- was looking, was taking care
<i>noduve</i>	- will look
<i>nokrathu</i>	- looking to look
<i>nokrusku</i>	- seeing looking
<i>olampu</i>	- body
<i>ol</i>	- society done by outsiders
<i>olathu</i>	- to call, to address

<i>ole</i>	- address term for females of same age group or T₀iHiger to age
<i>oli</i>	- one who had sexual inter course
<i>one</i>	- address term for males of same age group or younger to age
<i>onnum</i>	-nothing
<i>ontu</i>	-one
<i>ontuthe</i>	-same
<i>ooru</i>	- hamlet
<i>oorukarar</i>	- hamlet members
<i>oottattu</i>	- a type of funeral dance
<i>ore</i>	- one
<i>ottidheetti</i>	-joined verandah of two or more linear hots
<i>paadi</i>	- valley
<i>paccha savu</i>	- green-funeral
<i>padi</i>	- wooden measure
<i>paji</i>	- hunger
<i>pakkakadi</i>	- old farm land
<i>palame</i>	- old events
<i>pali</i>	- plantain seedlings
<i>Palli pattan</i>	- ancestral god of Mele-Abbanoor
<i>panant</i>	- money
<i>panchavath</i>	- formal meeting of the council members of an hamlet
<i>pankirathu</i>	- to share
<i>panti</i>	- pig
<i>para</i>	- pot shaped drum with leather on one side
<i>parayattu</i>	- a type of funeral dance
<i>pariyu-panam</i>	- bride-Price
<i>pashe</i>	- like
<i>pattada</i>	- strong bamboo platform erected on four legs in a corner of the kitchen <i>tot</i> keeping big baskets of grains and other utensils
<i>pat hu</i>	- ten
<i>putta</i>	-leaf

<i>pattan pattanar</i>	- kin type : great grand-father , term used to refer ancestor.
<i>pattan-kalu</i>	-descent line
<i>pattukaran</i>	- shamam who finds the cause of a decease and prescribe the remedy through singing
<i>-pe</i>	- an affix used to address males of the same age group or young to age
<i>pei</i>	- ancestral god (particularly the super natural power)
<i>pendu</i>	-wife
<i>pennu (pen)</i>	- female
<i>pennu</i>	-woman
<i>pennu koom barunthathu</i>	- bnnnging of bride to the groom's hamlet associated with mamage.
<i>pennu-vela</i>	- bnde service
<i>peru pidishirathu</i>	- giving of name
<i>peru</i>	- name
<i>peshtheerkal</i>	• settle the issue through discussion
<i>petta pillai</i>	- female children
<i>pichathu</i>	- an evil spirits
<i>pichathu</i>	- evil spirit
<i>pidikkal</i>	- to hold
<i>pidishirathu</i>	• 10 catch
<i>pilla phalam</i>	- symbol of fert litv.
<i>pilli</i>	- black magic done by their people
<i>pirannavan</i>	- one who took birth
<i>pirathina</i>	- one who gave birth (genutor)
<i>pirru</i>	- steamed cake
<i>pokumodu</i>	- will you go
<i>ponnan</i>	- terra of address for younger brother and torn
<i>ponni</i>	- term of address for younger sister and daughter
<i>poornu</i>	-cross poles used vertically for roofing
<i>pukkumathu</i>	- entered

<i>puli</i>	- tamarind
<i>pulirasam</i>	- curry made of tamarind
<i>randu</i>	- two
<i>saakkukooli</i>	- compensation for looking after the children
<i>saavu</i>	- corpse, funeral
<i>sakke</i>	- jack fruit
<i>sala</i>	- watch hut
<i>sande</i>	- quarrel
<i>sathathu</i>	- dead one
<i>sattu</i>	- pot
<i>saval valli</i>	- a tuberous plant (<i>Dioscorea sp</i>)
<i>savu</i>	- corpse, funeral
<i>seedhanam</i>	- a counter prestation to bride-price made by the bride's father to the groom's kin
<i>seela</i>	- cloth
<i>seema</i>	- territory
<i>seeru</i>	- ancestral festival
<i>seithathukku</i>	- for getting done
<i>semu chevraathu</i>	- a ritual associated with funeral, where the wife of the dead man keeping a pot of water on her head takes three circles round the corpse and after the third round, on reaching the foot part of the corpse, drops the pot breaking it into pieces
<i>sethan</i>	- to join
<i>sinna</i>	- small
<i>sole</i>	- forest
<i>solli</i>	- to tell
<i>soppu</i>	- green tettes. leafy plants
<i>son*</i>	- rice
<i>terru</i>	- do not know
<i>thi stot</i>	- senior most
<i>thammu</i>	- they

<i>thannu</i>	- water
<i>thappu</i>	- sin
<i>thayi</i>	- an evil spirit
<i>thaze</i>	- down side
<i>thcebendi</i>	- camp fire
<i>thcerum</i>	- will end
<i>thekku</i>	- small bamboo basket with wide mouth for keeping grams
<i>theva</i>	- an evil spirit
<i>thinnal</i>	- if you eat
<i>thodu</i>	- initiation ceremony associated with harvest
<i>tholla</i>	- cradle
<i>thuna</i>	- support
<i>thunakkan</i>	- friend
<i>ujiru</i>	- life
<i>ulakka</i>	- mortar
<i>ullara</i>	- the area inside the kitchen which is towards the hearth
<i>ural</i>	- pestle
<i>uraw</i>	• small water spring
<i>unmet</i>	- right or claim in one's cross-cousin
<i>vanna padt</i>	- amount of ncc supplied to the guests from other hamlets during funeral ceremonies
<i>veduruthu</i>	• paying of
<i>veeniar</i>	- young girls
<i>ktittupadi</i>	• Amount of rice supplied to the residents of the lunik during funeral ceremonies
<i>velikadathirut u</i>	• bringing out
<i>lettara</i>	• the area inside the kitchen which is towards the entrance
<i>vetti</i>	• white cloth
<i>vithu</i>	- seed

BIBLIOGRAPHY

- Aiyappan, A. 1948. *Reports on the socio-economic conditions of the aboriginal tribes of the province of Malabar*. Madras : Madras Government Press.
- Aiyappan, A. 1969. *Urgent research in Social Anthropology*. Simla . Indian Institute of Advanced Studies.
- Aiyappan, A. and C J Jayadev 1958. Megalithic survival among the Mudugas of Attapady valley, Kerala. *Adibasi* 3 (2).
- Allen, NJ. 1975. Byansi kinship terminology : A study in symmetry. *Man* 10, 80-94
- Ananthakshna Iyer, L.K. and L K.Bala Ratnam 1961. *Anthropology in India* Bombay Bharatiya Vidya Bhavan.
- Barnad, Alan, and Anthony Good (eds) 1984. *Research practices in the study of kinship* (ASA Research methods in Social Anthropology 2). London . Academic Press.
- Barnes, J A. 1962. African models in the New Guinea highlands. *Man* 62. 5-9
- Barnes, J A 1967 Agnation among the Mae Enga : a review article *Oceania* 38, 33-43
- Barnett, S 1976. Coconuts and gold . relational identity in a South Indian caste *Contributions to Indian Sociology*, 133-156
- Barth, F. 1966. *Models of social organisation* (Royal Anthropological Institute, Occasional papers 23) London : Royal Anthropological Institute
- Barth, F. 1973. Descent and marriage reconsidered. In *The character of kinship* (ed) Jack Goody. London : Cambridge University Press.
- Beck, Brenda E 1972 *Peasant society in Koutu* Vancouver University of British Columbia.
- Befu, H and L Plotnicov 1962 Types of corporate unilineal descent groups. *American Anthropologist* 64, 313-327
- Bender, R. Donald 1967 A refinement of the concept of families, co-residence, and domestic functions. *American Anthropologist* 69 493 504
- Berndt, R. 1964. Warfare in the New Guinea highlands. *American Anthropologist* 66, Part 2, 183-203 (special publication).

- Bossen, L 198 S. Toward a theory of marriage : the economic anthropology of marriage transactions *Ethnology* 27, 127-144.
- Bourdieu, P. 1977. *Outline of a theory of practice*. Cambridge r Cambridge University press
- Burkhart, G 1978 Marriage alliance and the local circle among some udayars of South India. In *American studies in the anthropology of India* (ed.) S.Vatuk, PP.171-120. New Delhi : Manohar.
- Busby, C. 1997 Of marriage and marriageability : Gender and Dravidian kinship *Journal of Roy al Anthropological Institute*, 3, 21-42.
- Carter, A T 1974 A comparative analysis of systems of kinship and marriage in South Asia. *Proceedings of the Royal Anthropological Institute*, 1 973, 29-54
- Comaroff, J (ed) 1980 *The meaning of marriage payments*. London : Academic press.
- Coppet, D de 1981 The Life-giving death. In *Mortality and Immortality : the Anthropology and Archaeology of death* (eds) S C.Mumphreys and Helen King. London • Academic Press
- Coult, Allan D 1962 The determinants of differential cross-cousin marriage *Man* 62, 34-36
- Danda, A K 1973 Determinants of Kosalanadu Brahmin kinship terminology *Man in India* 53
- David, Kenneth, 1973 Until marriage do us part a cultural account of Jaffna Tamil categories for kinsmen. *Man* 8, 521-535
- De Lepervanche, M 1967-68. Descent, residence and leadership in the New Guinea highlands *Oceania* 38 (2), 134-158, (3),163-189
- Devenport, William, 1959 Non unilinear descent and descent group*. *American Anthropologist* 61, 557-572.
- Dumont, L. 1953 The Dravidian kinship terminology as an expression of marriage *Man* 53, 34-39
- Dumont, L. 1957. *Hierarchy and marriage alliance in South India kinship*. Royal anthropological institute, occasional paper 12). London Royal Anthropological Institute.

- Dumont, L. 1953. *Affinity as a value : marriage alliance in South India with comparative essays on Australia*, Chicago : University of Chicago press.
- Dumont, L. 1986 (1957). *A South Indian sub-caste: Social organisation and religion of the Paramalai Kallar* (Translated by M.Moffatt and A.Morton). Delhi : Oxford University Press.
- Evans-Pritchard, E.E (1951). *Kinship and marriage among the Nuer*. Oxford : Clarendon Press
- Firth, Raymond 1951. *We the Tikopia*. London : George Allen and Unwin.
- Firth, Raymond 1957. A note on descent groups in Polynesia. *Man* 57, 4-8
- Firth, Raymond 1963. Bilateral descent groups : an operational view point. In *studies in kinship and marriage* (ed) I.Schapera. London : Royal Anthropological Institute.
- Fortes, M 1953. The structure of unilineal descent groups *American Anthropologist* 35. 17-41
- Fortes, M 1962 Introduction In *Marriage in tribal societies* (ed) M Fortes (Cambridge papers in Social Anthropology 3) Cambridge . Cambridge University Press Freeman 1951
- Fortes, M 1969 *Kinship and the social order the legacy of Lewis Henry Morgan*. Chicago Aldine
- Fortes, M 1978 (1958) Introduction *In the development cycle in domestic groups* (ed) J Goody, PP.1-14, Cambridge ; Cambridge University Press.
- Freeman, J.D 1958. The family system of the Iban of Borneo *In the Developmental cycle in Domestic groups* (ed.) J Goody (Cambridge papers in Social Anthropology 1) Cambridge . Cambridge University Press.
- Fruzzetti, L., Akos Ostor and Steve Barnett 1976 Seed and earth a cultural analysis of kinship in a Bengali town. *Contributions to Indian Sociology* 10, 97-132
- Fruzzetti, L., Akos Ostor and Steve Barnett 1976. The cultural construction of the person in Bengal and Tamil Nadu. *Contributions to Indian Sociology* 1 157-182
- Fruzzetti, L. Akos Ostor and Steve Barnett 1982. *Concepts of person Kinship and marriage in India* (Harvard studies in cultural anthropology 5) Delhi Oxford University Press.
- Fuchs, Stephen 1973. *The aboriginal tribes of India* New Delhi Macmillan India

- Furer-Haimendorf, C. 1959. Hereditary friendship and intertribal sex relations between Todas and Mudugas. *Man* 54, 28-29.
- Good, Anthony, 1980. Elder sister's daughter marriage in South Asia. *Journal of Anthropological Research*, 36, 474-500.
- Good, Anthony. 1981. Prescription, preference and practice : marriage patterns among the Kondaiyan Kottai Maravar of South India. *Man* 16, 108-129
- Good, Anthony 1985. Markedness and extensions : the Tamil case. *Mart* 20, 545-547
- Good, Anthony 1991. *The female bridegroom : rituals of puberty and marriage in south India and Sri Lanka*. Oxford : Clarendon Press.
- Goodenough, W.H. 1955. A problem in Malayo-Polynesian social organisation. *American Anthropologist* 57, 71-83
- Goodenough, W H 1962 Kindred and hamlet in Lakalai, "New Britain" *Ethnology* 1, 5-12.
- Goodenough, W H 1970 *Description and comparison in cultural anthropology* Cambridge - Cambridge University Press.
- Goody, Jack 1958 *The development cycle in domestic groups* Cambridge Cambridge University Press.
- Goody, Jack (ed.) 1973 a. *The character of kinship* Cambridge Cambridge University Press
- Goody, Jack and S.J.Tambiah (eds.1973 b *Bridewealth and dowry* Cambridge Cambridge University Press.
- Gough, E Kathleen 1956. Brahman kinship in a Tamil village *American Anthropologist* 58, 826-853
- Gough, E Kathleen 1959 The Nayar and the definition of marriage *Journal of the Royal Anthropological Institute* 89 23 34
- Held, DJ 1957 *The Papuas of New Guinea* The Hague Mouton
- Hertz, R. 1907 Contribution a une étude sur la représentation collective de la mort *Année sociologique* 10, 45-137

- Holy, L. 1976. Kin groups : structural analysis and the study of behaviour. *Annual Review of Anthropology* 5, 107-131.
- Homans, George C. and David M. Schneider (eds.) 1955. *Marriage, authority, and fatal causes : a study of unilateral cross-cousin marriage*. Glencoe : The Free Press.
- Huntington, R. and P. Metcalf. 1979. *Celebrations of death : the anthropology of mortuary ritual*. New York : Cambridge University Press.
- Jones, Todd 1988. Interpretive social science and the "native's point of view" : a closer look *Philosophy of the Social Sciences* 28 (1), 32-68.
- Kapadia, K 1993. Marrying money : Changing preference and practice in Tamil marriage *Contributions to Indian Sociology* 27, 25-51.
- Kapadia, K. 1994 "Kinship burns ! kinship discourses and gender in Tamil South India. *Social Anthropology* 2, 281-297.
- Kapadia, K M 1966 *Marriage and family in India*. Calcutta * Oxford University Press.
- Kapp, D B 1978 Palu Kurumba riddles - specimens of a South Dravidian tribal language *Bulletin of the School of Oriental and African Studies* 41, 512-522.
- Kapp, D B 1980 Die ordination despriesters bei den Alu-Kurumbas (Südindien) *Anthropos*, 75, 433-446
- Kapp, D B and Paul Hockings, 1989 The Kurumba tribes. In *The Nilgiris: the ethnography and biogeography of a south Indian region* (ed) Paul Hockings. Oxford . University Press.
- Kapp, D B. 1985. The Kurumbas' relationship to the "Megalithic" cult of the Nilgiris (South India) *Anthropos* 80, 493-534
- Keesing, R.M. 1970 Shrines, ancestors and cognatic descent the Kwazoo and Tallensi *American Anthropologist* 72 (4) 755-75
- Keesing, R.M 1971. Descent, residence and cultural codes. In *Anthropology in Oceania* (eds). L R. Hiatt and C. Jayawardena. Sydney Angus and Robertson.
- Khan, C G H 1994 *Marriage and Kinship among Muslims in South India* New Delhi Rawat publications.
- Kodanda Rao, M. 1982 Kinship and marriage among the Jalaris of coastal Andhra A study of Dravidian kinship terminology *Contributions to Indian Sociology* 16, 197-223.

- Kolenda, P.M 1968. Region, Caste and family structure : A comparative study of the Indian "joint" family. In *structure and change in India society* (eds) M.Singer and B S Cohn, pp.339-396. Chicago : Aldine.
- Kopytoff, I. 1977. Matrilineality, residence and residential zones. *American Ethnology* 4, 539-558.
- Kuper, A 1982. Lineage theory : a critical retrospect. *Annual Review of Anthropology*, 11,71-95
- La Fontaine, K. 1973. Descent in New Guinea : an Africanist view. In *The character of kinship* (ed) Jack Goody. Cambridge : Cambridge University Press.
- Langness, L L 1964 Some problems in the conceptualization of Highlands social structure. *American Anthropologist* 66, Part 2, 162-182 (special publication).
- Leach, E R 1951. The structural implications of matrilineal cross-cousin marriage. *Journal of Royal Anthropological Institute* 81, 54-104.
- Leach, E R 1961 *Rethinking anthropology* London : Athlone Press
- Leach, E R 1964 *Political systems of Highland Burma* London Athlone Press.
- Levi-Strauss, C 1969 *The elementary structures of kinship* London • Eyre and Spottiswoode
- Lewis, Joan M 1965 Problems in the comparative study of unilineal descent. *The relevance of models for social anthropology* (ed.) M Banton (ASA Monograph 1) London Tavistock publications
- Lipuma, E 1988 *The gift of kinship structure and practice in Marung social organisation*, Cambridge : Cambridge University Press.
- Luiz, A A D. 1962. *Tribes of Kerala* New Delhi Bharat ya Adimj ati Sev ak Sangh
- Madan, T.N. 1965 *Family and kinship a study of the Pundits of rural Kashmir* Bombay : Asia Publishing House
- Malinowski, B 1930 Kinship. *Man* 30. 19-29
- Mayer, A.C. 1960. *Caste and kinship in Central India*. London Routledge and Kegan Paul
- McCormack, W.C. 1958 Sister's daughter marriage in a Mysore village. *Man in India* 38, 34-48.

- Mc Gilvray, D B 1980 *Sexual power and fertility in Sri Lanka : Batticaloa Tamils and Moors* In *Ethnography of Fertility and Birth* (ed.) C.P.MacCormack. Cambridge . Cambridge University Press.
- Meggitt, M J 1962. *Desert people*. Sydney : Angus and Robertson.
- Meillassoux, C 1981. *Maidens, meals and money : capitalism and the domestic economy* Cambridge : Cambridge University Press.
- Morgan, L H 1871. *Systems of consanguinity, and affinity of the human family* Washington : Smithsonian Institution.
- Mathur, P R G 1977 *Tribal situation in Kerala*. Trivandrum : Kerala Historical society.
- Murdock, G P 1949. *Social structure*. New York : Macmillan
- Needham, R. 1962 *Structure and sentiment*. Chicago : University of Chicago press.
- Needham, R 1972 *Belief, language and experience*, Oxford . Basil Black well
- Noble, W A 1976 Nilgiri dolmens (South India). *Anthropos*, 71- 90-128
- Noble, W A 1989 (1981) Nilgiri prehistoric remains In *The Blue mountains the ethnography and biography of a South Indian region* (ed) Paul Hockings. Oxford Oxford University Press
- Parkin, Robert, 1996 On Dumont's 'affinal terms' : comment on Rudner contribution to *Indian Sociology* 30, 289-97.
- Parry, J P 1979 *Caste and Kinship in Kangra* London Routledge and Kegan Paul.
- Peletz, Michael G 1995. Kinship studies in late twentieth century anthropology *Annual Review of Anthropology* 24 : 343 372
- Pouwer, J 1960 Loosely structured societies in Netherlands, New Guinea. *Bladgen : de Taal-, Land-, en Volken Kunde* 116, 109-18
- Radcliffe-Brown, A.R. 1924 The mother's brother in South Africa. *South African Journal of Science* 21.
- Radcliffe-Brown, A.R. 1941. The study of kinship systems. *Journal of Royal Anthropological Institute*. 70 (also in A.R.Radcliffe-Brown 1952. 49-89
- Radcliffe-Brown, A.R. 1950. Introduction. In *African systems of kinship and marriage* (eds) A.R. Radcliffe-Brown and D Forde Oxford University Press.

- Radcliffe-Brown, A.R. 1952. *Structure and function in primitive society*. London : Cohen and West.
- Radcliffe-Brown, A.R. and D. Forde (eds.) 1950. *African systems of kinship and marriage*, Oxford : Oxford University Press.
- Ratha, S.N. 1971. Mountain : Matrilateral cross cousin marriage among the Komuta, data for a South Orissa village. *Folklore* 12 (10).
- Reddy, N.Subba 1984. The essence and evanescence of Dravidian kinship system. *Asian Profile* 12 (4), 367-385.
- Rivers, W.H.R. 1906. *The Todas*. London : Macmillan.
- Rivers, W.H.R. 1924. *Social organization*. London : Kegan Paul.
- Rudner, David, 1990. Inquest on Dravidian kinship : Louis Dumont and the essence of marriage alliance *Contributions to Indian Sociology* 24, 153-174
- Rudner, David 1997. Re-exhuming Dravidian kinship : a response to Parkin *Contributions to Indian sociology* 31, 299-311
- Sahahns, M D 1965 On the ideology and composition of descent groups *Man* 65. 104-107.
- Scheffler, H W 1966 Ancestor worship in anthropology or, observations on descent and descent groups. *Current Anthropology* 7, 541-551
- Scheffler, H W 1973 Kinship, descent and alliance In *Handbook of social and cultural anthropology* (ed.) J.Honigmann Chicago Rand Mc Nally
- Schemer. W H 1984 Markedness and extensions the Tamil case. *Man* 9, 557-574
- Schneider. DM and Kathleen Gough 1961 *Matrilineal kinship* Berkeley University of California Press,
- Schneider. D M 1965 Some muddles to the models or how the system ml > works. In *the relevance of models for social anthropology* (ed) M Baston (ASI Monograph 1) London, Tavistock Publications.
- Shah, AM. 1974 *The household dimension of the family in India*. London University of California Press.
- Spiro, E. 1977 *Kinship and Marriage in Burma*. London University of California Press.

- Stauder, J. 1971. *The Majangir : ecology and society of a South Western Ethiopian people* (Cambridge studies in social anthropology). Cambridge : Cambridge University Press.
- Strathern, A.J. 1969. Descent and alliance in New Guinea highlands. *Proceedings of the Royal Anthropological Institute*, 1968, 37-52.
- Strathern, A.J. 1973. Kinship, descent and locality : Some New Guinea examples. In *The character of kinship* (ed.) Jack Goody. London : Cambridge University Press.
- Tambiah, S.J. 1958. The structure of kinship and its relationship to land possession and residence in Pata Dumbara, Central Ceylon. *Journal of the Royal Anthropological Institute* 88 Part 1, 21-45.
- Tambiah, S J. 1973. Dowry and bride wealth and the property rights of women in South Asia. In *Bridewealth and dowry* (eds.). J. Goody and S.J. Tambiah, Cambridge Cambridge University Press.
- Thurston, E. 1909. *Castes and tribes of Southern India*. Madras : Government Press.
- Trautmann, T.R. 1981. *Dravidian kinship*. Cambridge : Cambridge University press.
- Trawick, M 1990 *Notes on love in a Tamil family* Berkeley University of California Press
- Tyler, Stephen A 1966. Context and variation in Koya kinship terminology *American Anthropologist* 68, 693-707
- Van Gennep, A 1960 (1909) *The rites of passage* (translated by M B Vicedom and G L Caffee) Chicago : University of Chicago Press
- Verdon, M. 1980. Descent : an operational view *Man* 15, 129-150
- Yalman, N. 1962. The structure of the Sinhalese kindred a re-examination of the Dravidian terminology. *American Anthropologist* 64 548-575
- Yalman, N. 1967. *Under the bo tree studies in caste kinship and marriage in the interior of Ceylon* Berkeley : University of California Press.
- Vanagisako, S J. 1979 *Family and household the analysis of domestic groups. Annual Review of Anthropology* 8, 161-205
- Zvelebil, Kamī IV. 1981. Problems of identification and classification of some Indian tribes. *Anthropos* 76, 467-528.



A Muduga Nuclear Family



A Muduga Couple



A Muduga Woman



Woman sowing seeds – shifting cultivation

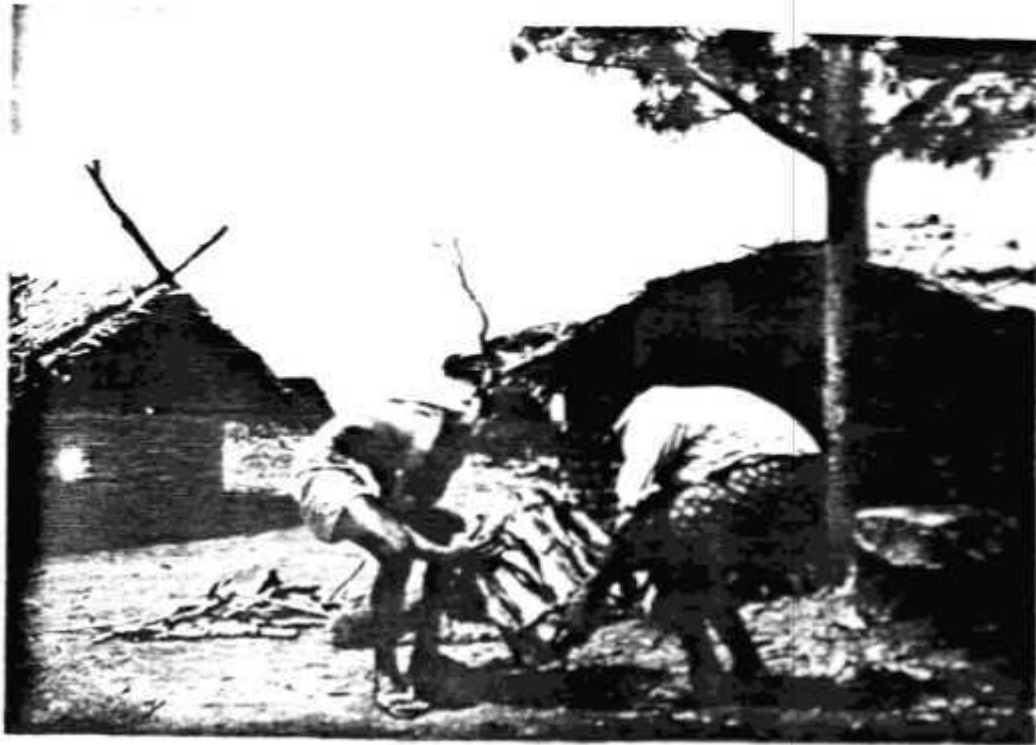

Affines sharing labour



***Pariya-Panam* payment during marriage**



Child rearing – fondling the child